

ÓSKOR



2

Stonehenge Bronzkor



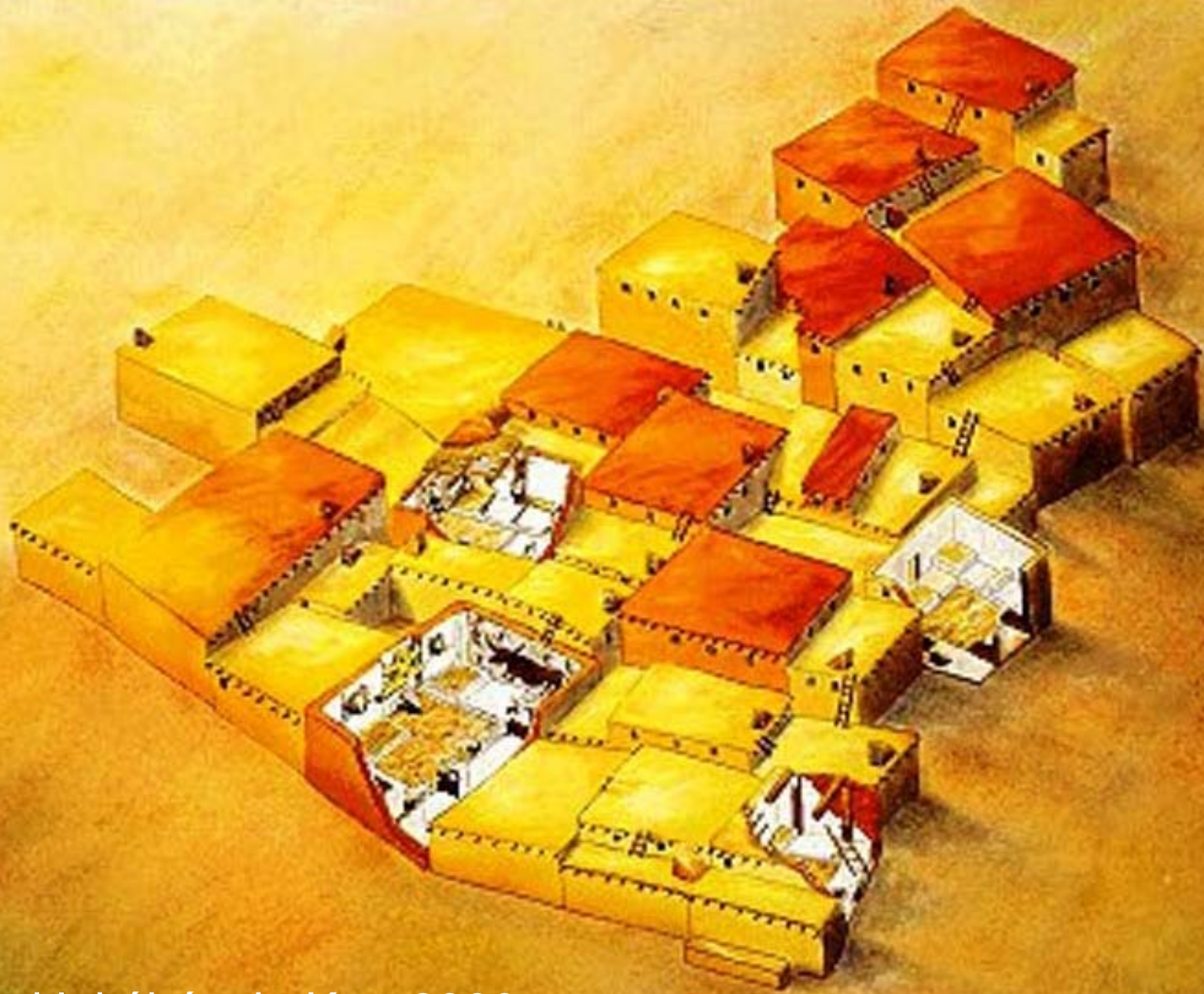

Őskori lakóházak, Kr.e.6000

Willendorfi Vénusz

Kr.e.30 000

Bécs, Naturhistorisches Museum





Lausseli Vénusz  
Kr. 30 000  
Franciaország



Szegvár-Tűzkövesi  
Újkőkor, Tiszai kult.  
Szentés, Koszta József  
Múzeum





Szkíta Aranyszarvas  
Kr.e.400  
Zöldhalompusztá  
Nemzeti Múzeum







Őskori barlangfestmények Kr.e.15 000  
Lascaux, Altamira



# ÓKORI EGYIPTOM



Narmer Palette Hierakonpoliszi Nagy Paletta  
Kr.e. 3000  
Kairó, Egyiptomi Múzeum



Palettákat festék dörzsölésre  
használtak a Nagy Paletta  
Egyiptom egyesítésének harcait ábrázolja







Dzsószér fáraó piramisa Kr.e.2700 Szakkara

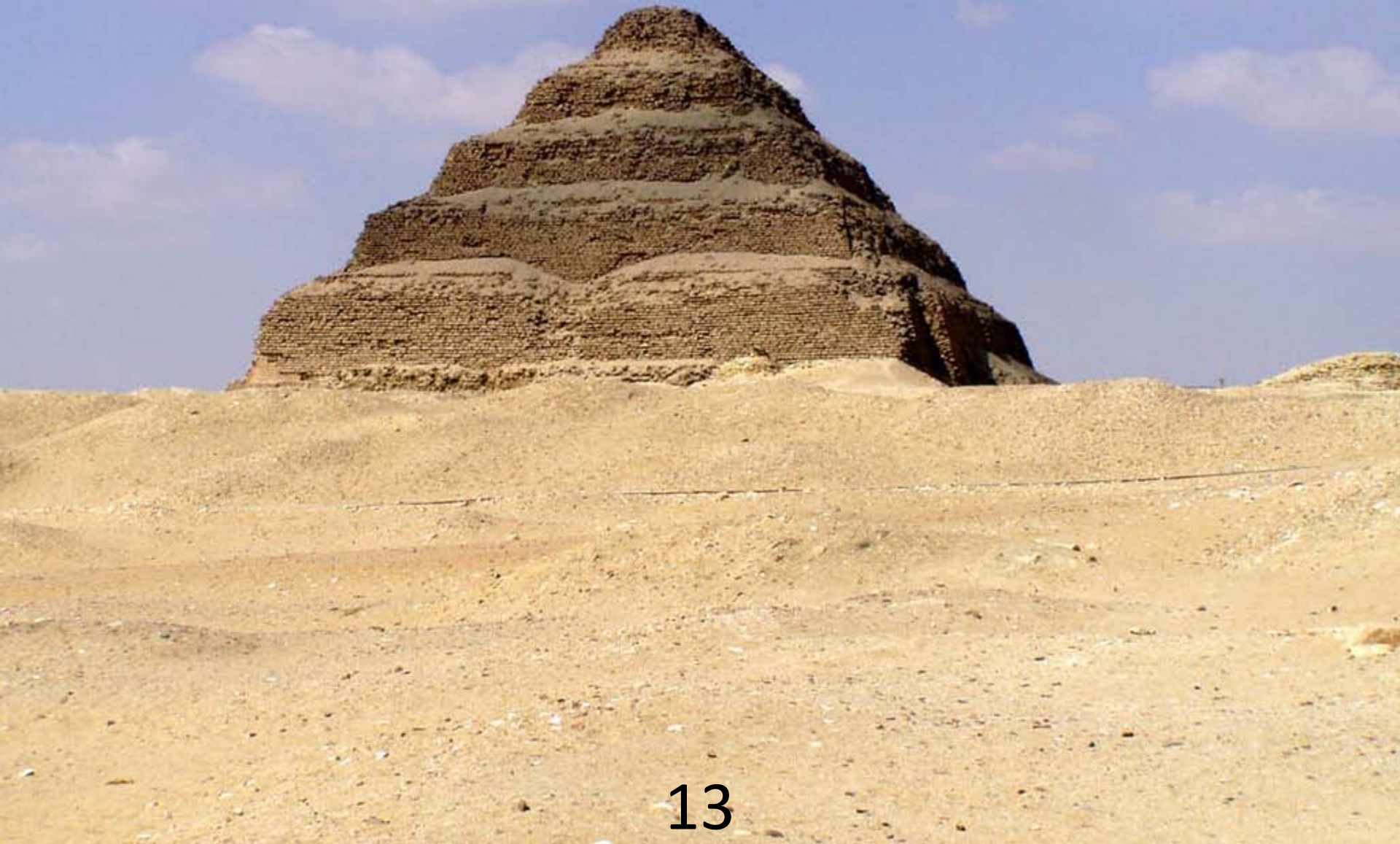

Gízai piramisok, Kheopsz fáraó piramisa, Kr.e.2600-2500 Óbirodalom





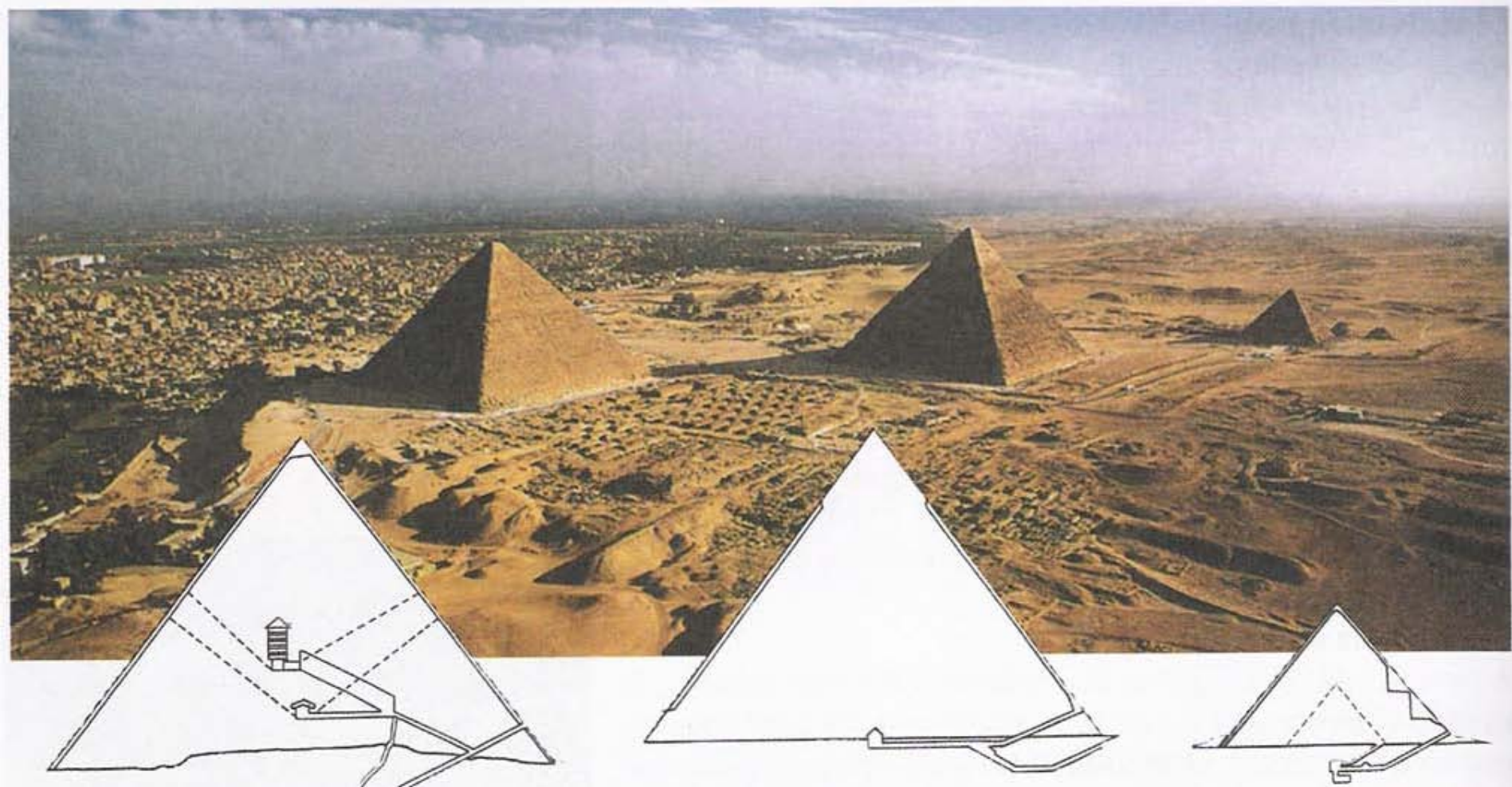

Gízai piramisok, Kheopsz, Khephrén, Mükerinosz fáraó piramisok, Kr.e2600



Ámon-Ré temploma, Középbirodalom, Kr.e.XVI-XII.sz. Karnak

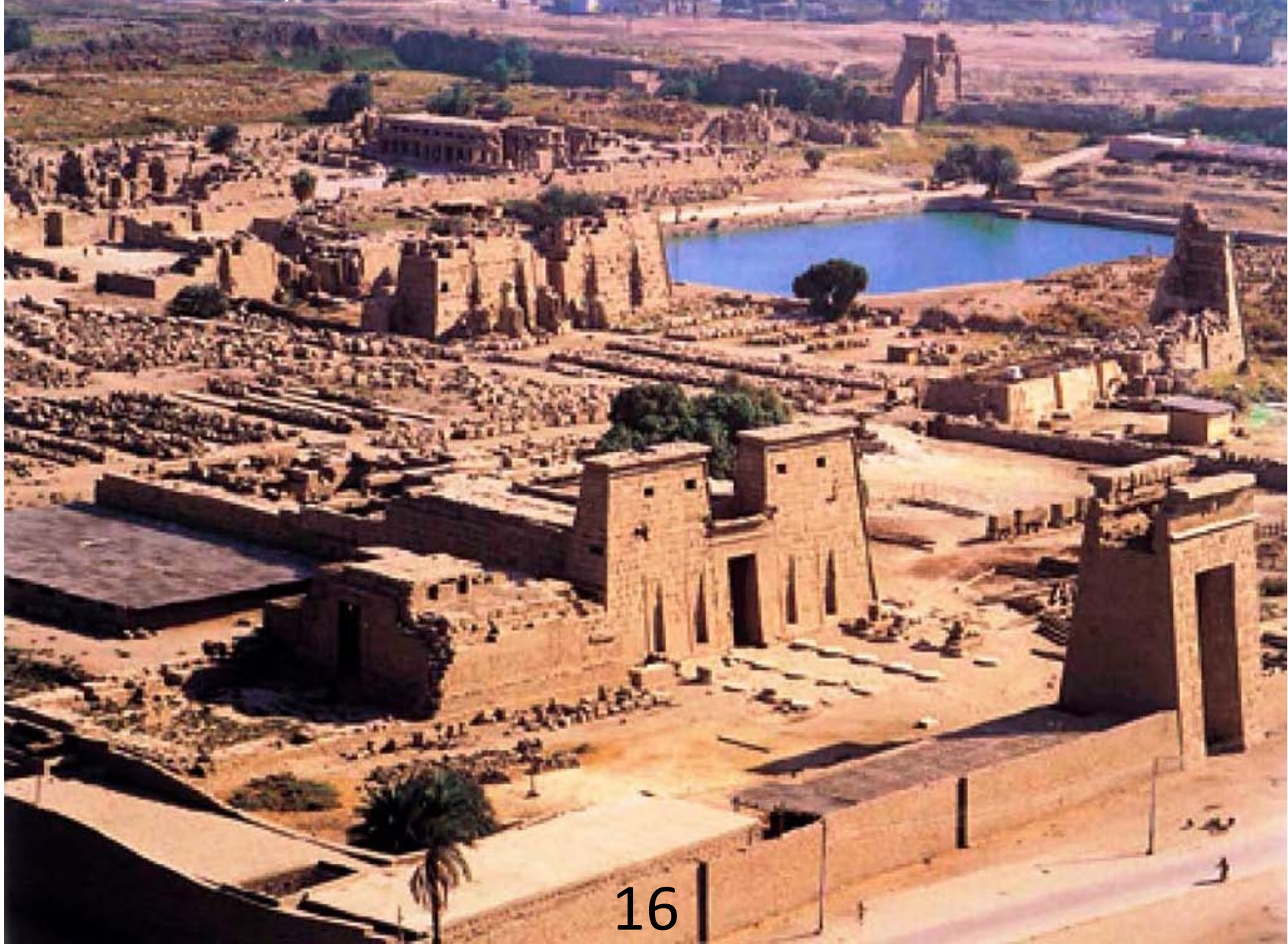



II. Ramszesz sziklatemploma, Újbirodalom, Kr.e.1300k.Abu-Szimbel

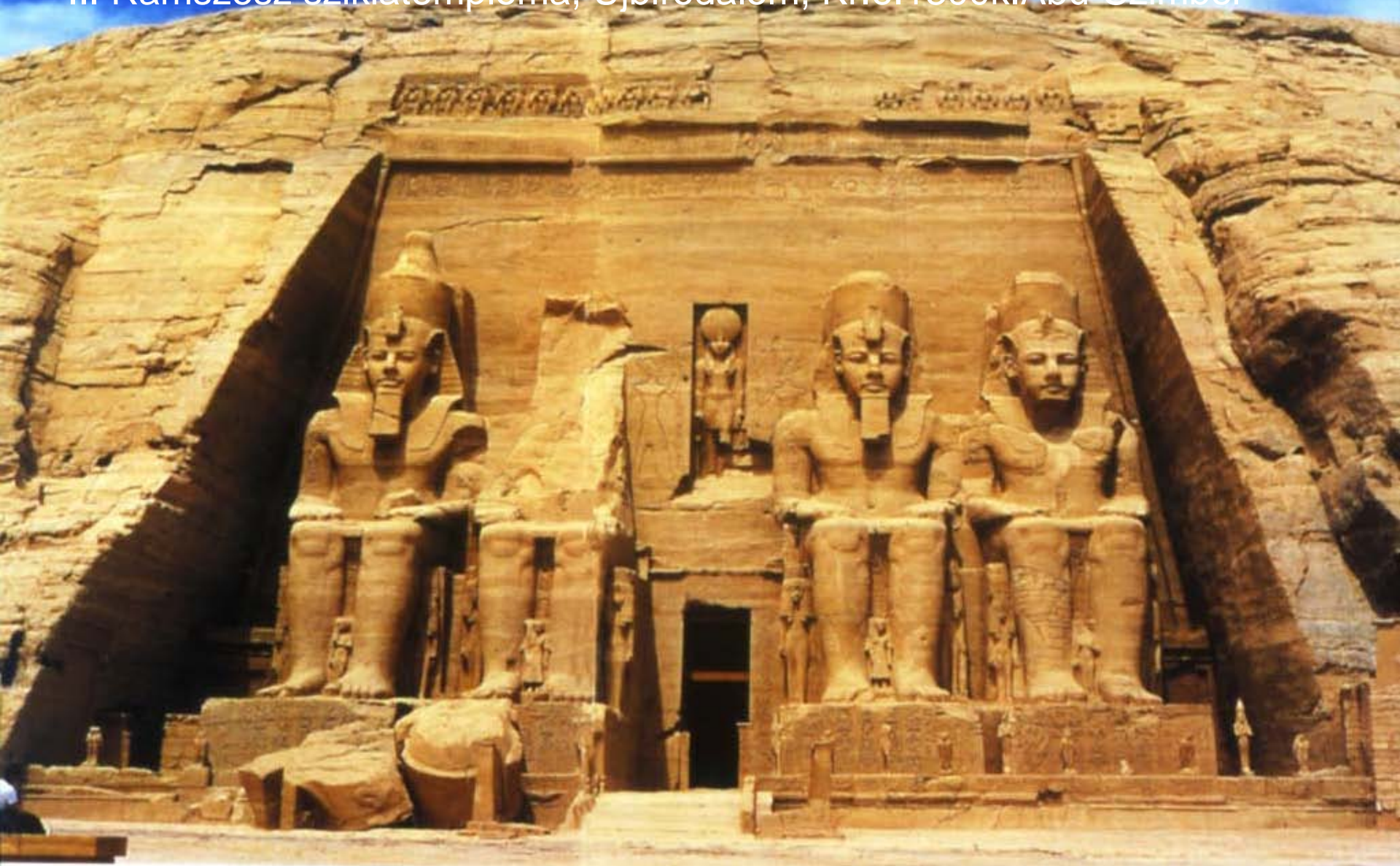

Írnok, festett mészkő, Óbirodalom  
Kr.e.III.ée  
Párizs, Louvre





Falusi bíró, Óbirodalom

Kr.e.III.ée

Kairó, Egyiptomi Múzeum



Kephrén  
Kr.e 2540-2505  
Kairó, Egyiptomi  
Múzeum





Mükerinosz-triász  
Kr.e.2480  
Kairó,  
Egyiptomi  
Múzeum





Anubisz szobra, Tutenchamon sírjából, Kr.e.1340, Kairó, Egyiptomi Múzeum



Echaton fáraó a családjával Kr.e.1360, Berlin, Staatliche Museen





Medumi ludak, falfestmény, Óbirodalom, Kr.e.2550, Kairó,  
Egyiptomi Múzeum





Halastó, thébai sír, falfestmény, Kr.e.1400, London, British Museum

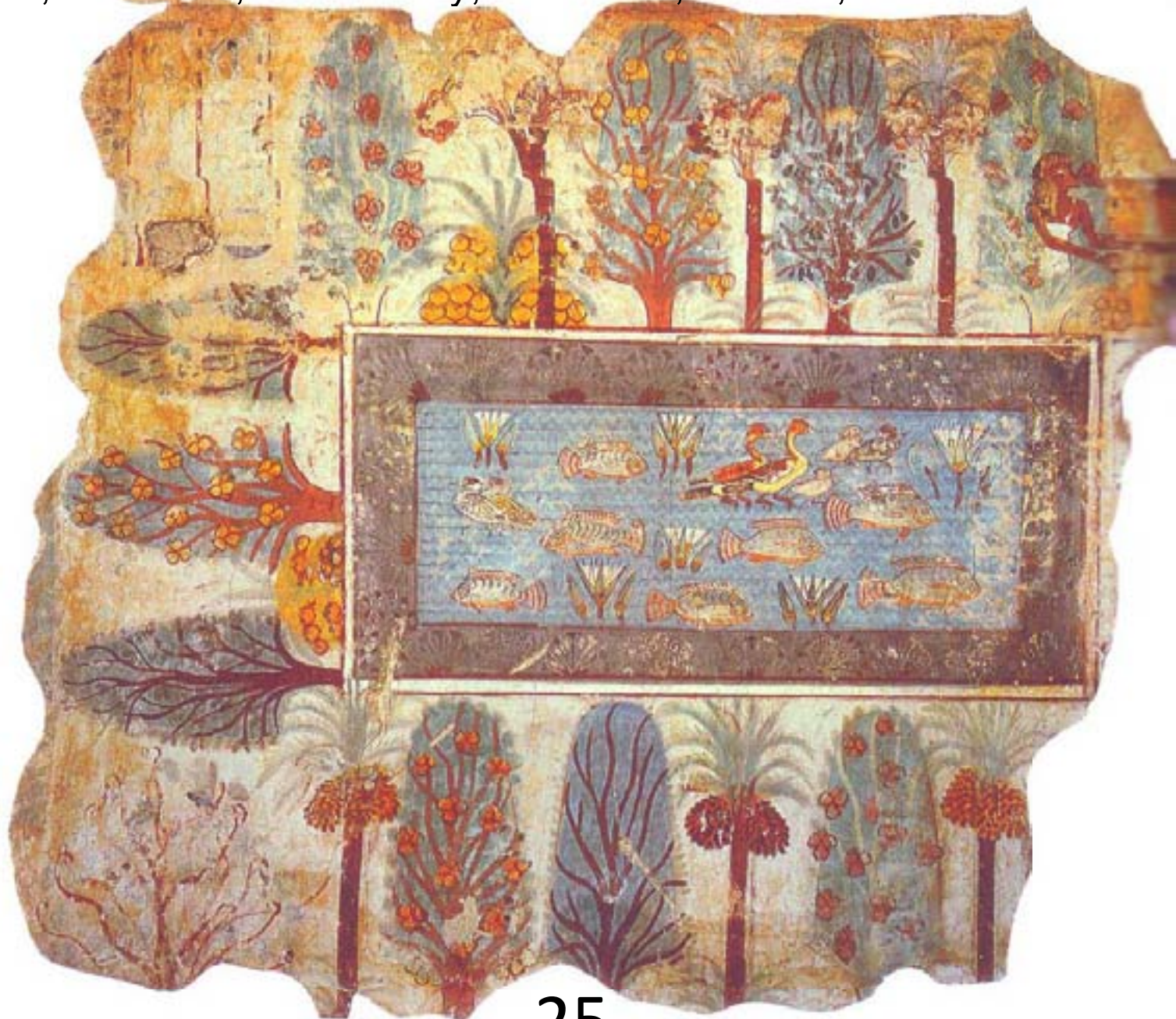



A fáraó vadászon  
thébai falfestmény  
Kr.e.XIV.sz.  
London, British Museum

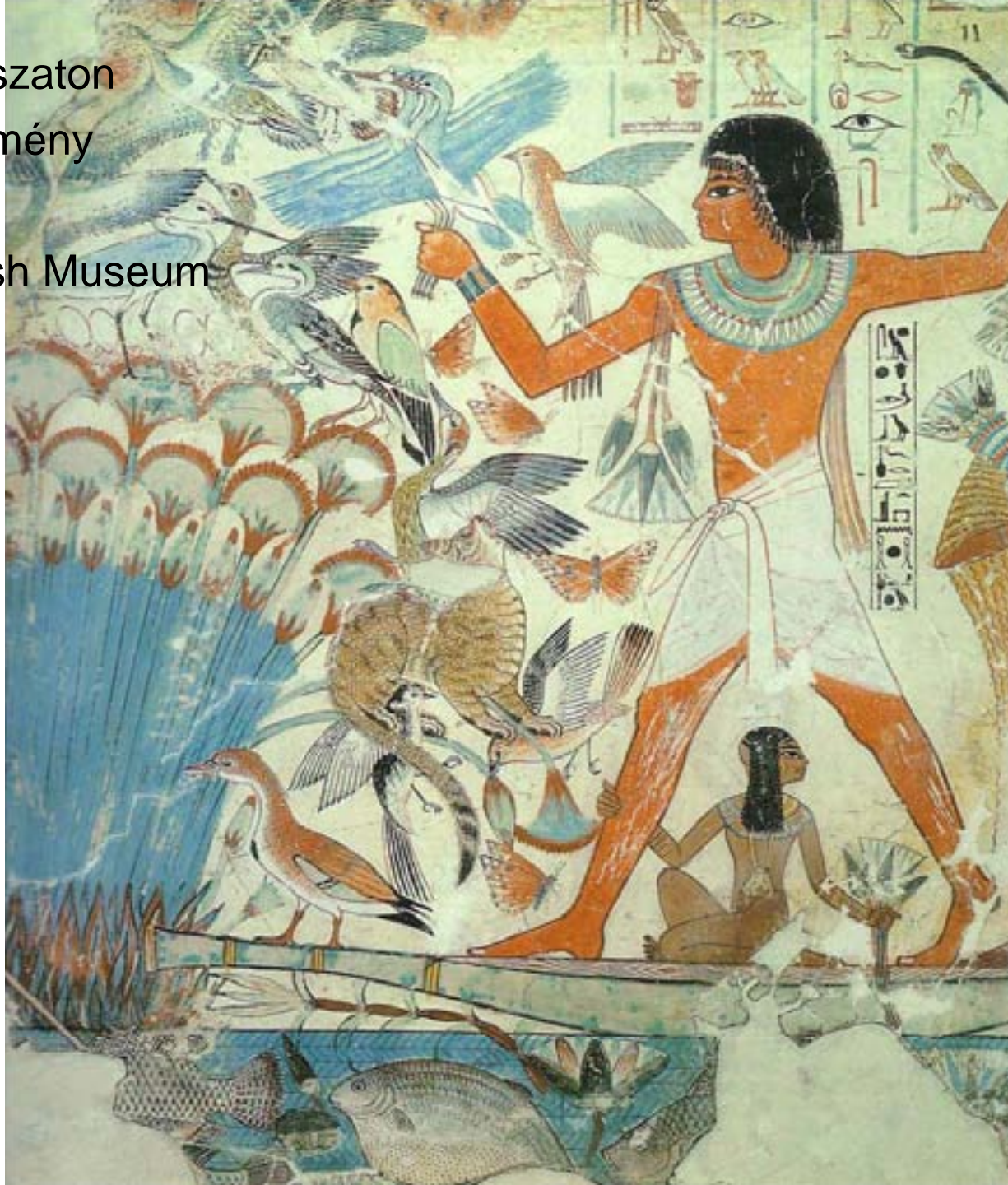



Tutenchamon halotti maszkja

Kr.e.1340

Kairó

Egyiptomi Múzeum





Bútorok Tutenchamon sírletéből

A fáraó trónusa, Kr.e.XIV.sz. Kairó, Egyiptomi  
Múzeum





Tutenchamon sírjában talált lelet, Nehbet keselyű mellédísz, Felső-Egyiptom keselyű istennőjét ábrázolja, Hórusz szemes mellédísz Nehpet és Udzsat Alsó-Egyiptom kobraistennője fog közre, Hórusz szeme a gyógyítást jelenti



# ÓKORI MEZOPOTÁMIA



Zikkurat, Kr.e 2000, Ur városában



Lamassu a kapuőrző

démon

Kr.e.IX.sz.

New York, Metropolitan





Babiloni Istar kapu

Kr.e.570

Berlin, Staatliche Museen

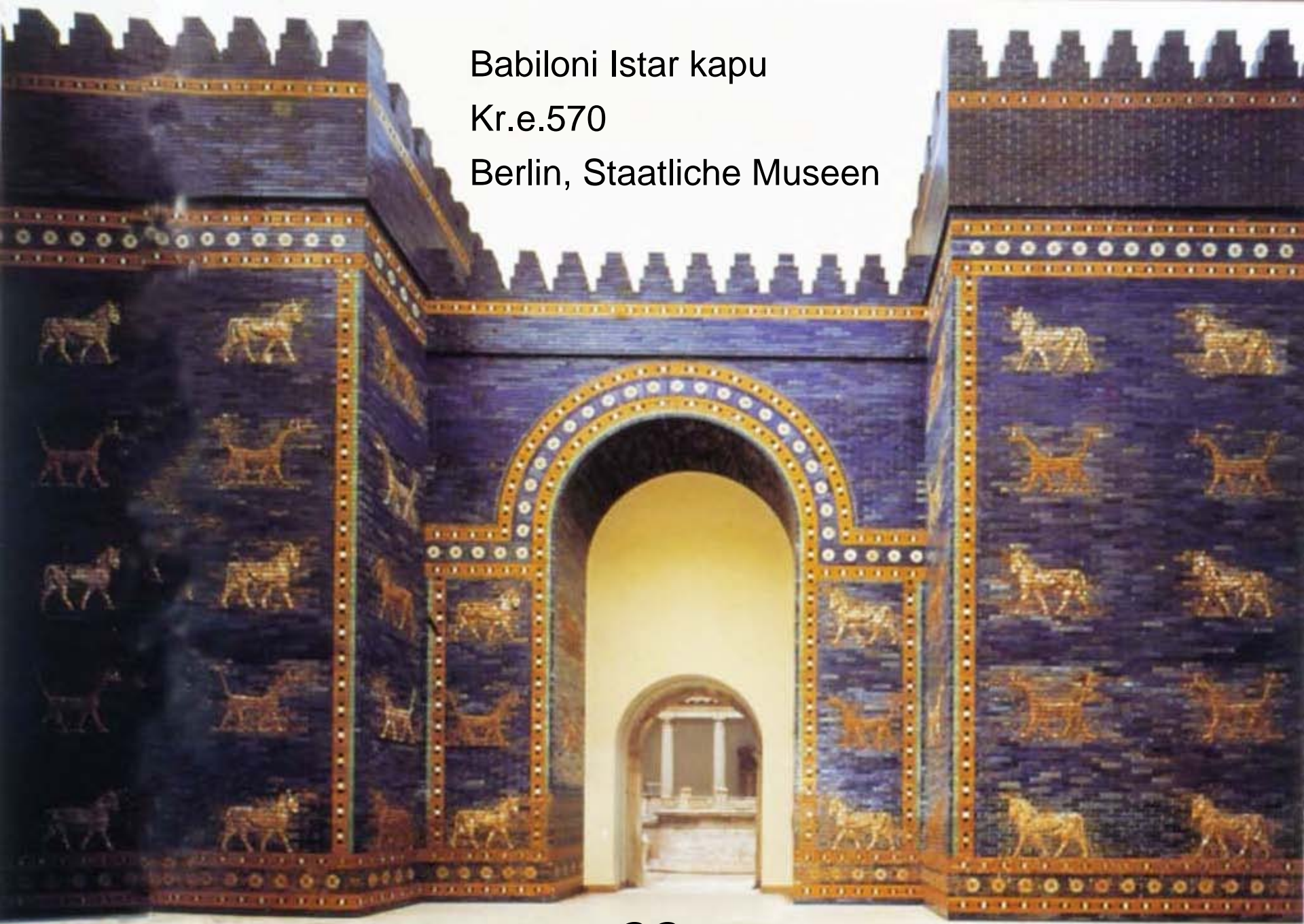

Alabástrom női fej

Uruk

Kr.e 2800

Bagdad,

Irak Múzeum





Bikafejes hárfa Ur városából

Kr.e 2500

Bagdad, Irak Múzeum



Gudea Lagas uralkodója  
italáldozatot mutat be

Kr.e.2120

Párizs, Louvre





Sumér ékírásos tábla vagy pecsételöhenger Kr.e.2000 London, British M.



# ÓKORI GÖRÖGORSZÁG



Knossoszi palota, Kréta  
Kr.e. XVI.sz.







Mükénei Fellegvár, Kr.e. XVI. sz.









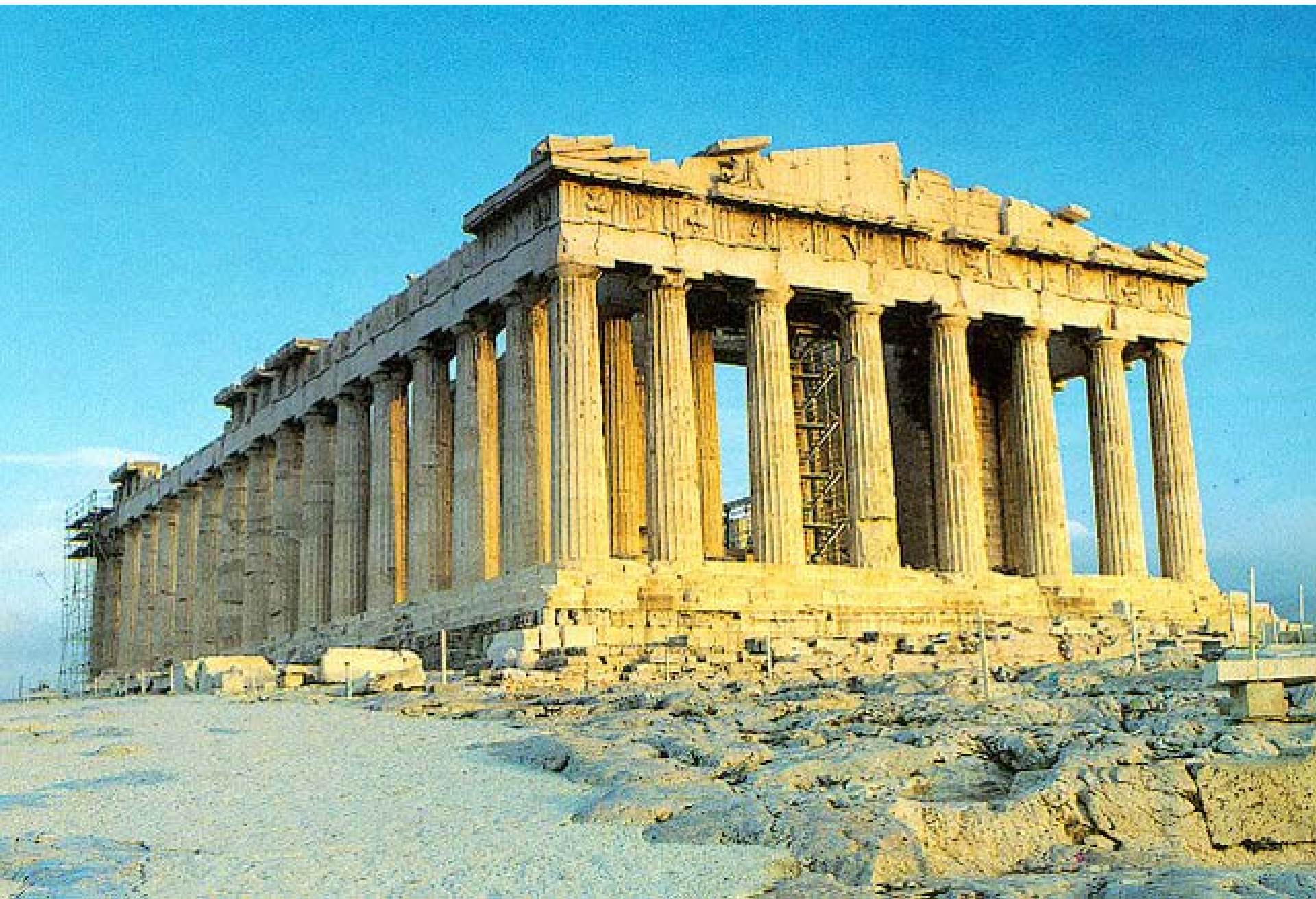

Athén  
Partheon, Pheidiász, Kr.e.V.sz

44 tervező: Iktinosz és Kallikratész



# Görög Színház romjai, Kr.e.IV.sz. Epidauros



Niké templom

Erechteidon Kariatidák csarnoka, Kr.e.421-406, Athéni Akropolisz

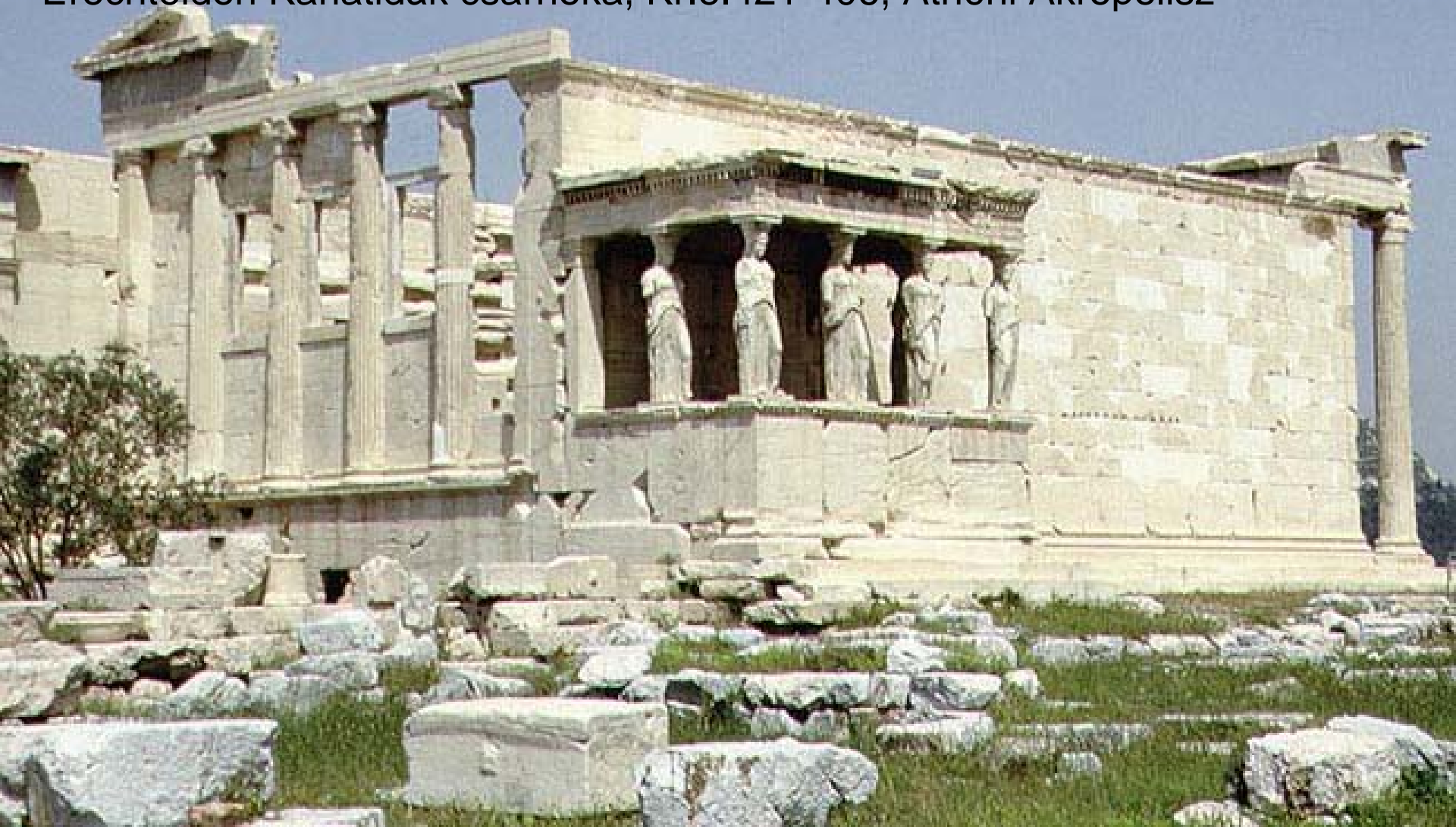



Zeusz oltára, Kr.e.180. Berlin, Pergamon Múzeum



Auxerre-i istennő  
Kr.e.650  
Párizs, Louvre



Imádkozó tartásban  
fogadalmi szobor



Anavüszoszi Kurosz  
Athénból, Kr.e 530  
Athén Nemzeti Múzeum



Kurosz szobor  
Athénból  
Kr.e.600  
New York  
Metropolitan  
Múzeum





Müron: Diszkoszvető  
római másolat-márvány  
eredeti bronz  
Kr.e.450  
Róma, Museo Vaticano



Polükleitosz: Dorüphorosz

Lándzsavivő

Kr.e.450

Nápoly, Muso Nazionale





Praxitelész:Knidoszi

Aphrodité

Kr.e.360 római márvány  
másolat

Róma, Vatikáni Múzeum



Delphoi kocsihajtó  
Kr.e.470  
Delphi Múzeum





Riaceai bronzszobrok  
sportolók vagy mitológiai hősök  
Reggio di Calabria,  
Régészeti Múzeum



Quirinale Ökölvívó,

bronz

Kr.e.300-200

Róma

Palazzo Massimo





Milói Vénusz

Kr.e 130

Antiókhiai Alexandrosz

Párizs, Louvre

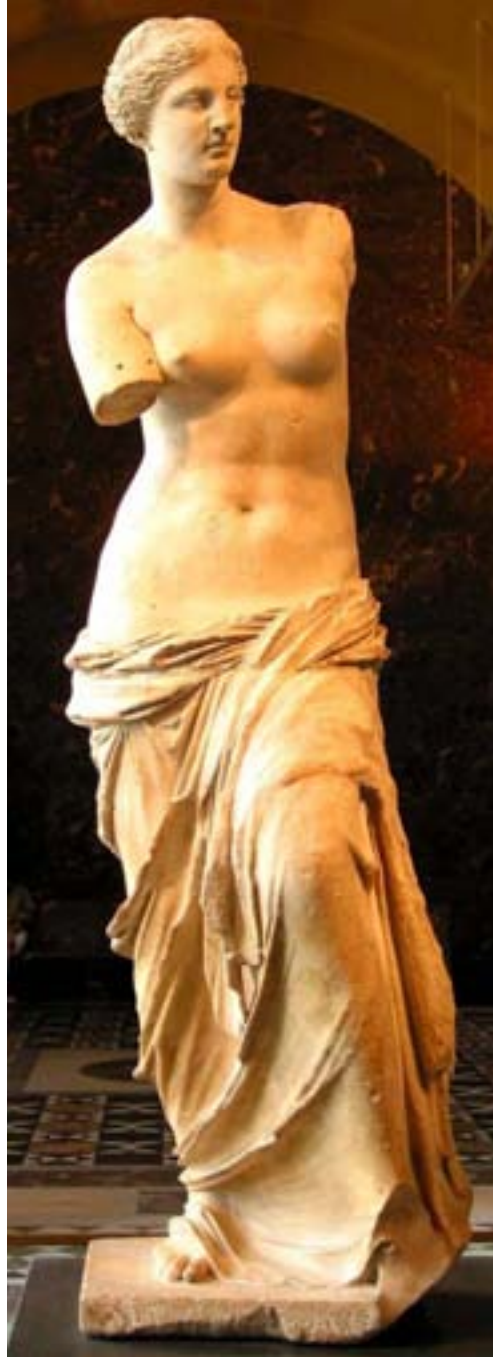

Szamothrakéi  
Niké Kr.e 200  
Párizs, Louvre



A győzelem  
istennője



Laokoóns szobor  
csoport

Kr.e.2.sz

Róma, Vatikáni

Múzeum



Athénodórosz  
és Polüdórosz

Feketealakos váza  
Kr.e.7.sz.  
Párizs, Bibliotecque  
Nationale





Vörös alakos kratér  
Kr.e. V-VI. sz.  
Párizs, Louvre



Orvietói kehely  
Heraklsz és társai

Pergamoni Héphaiszteón padlómozaikja, Kr.e 150  
Berlin, Staatliche Museen





ETRUSZK, RÓMAI

Etruszk sír, Cerveteri a holtak városa, kiterjedt nekropolisz







65 Etruszk sírszarkofág házaspárral, Kr.e.625 Róma, Museo Nazionale

Ficroni cista  
Kr.e.300 Róma  
kozmetikai szereknek  
vagy ékszereknek







67 Capitolumi farkas, Kr.e.500, bronz, Róma, Capitolino Múzeum

Colosseum, 70-90, Róma







69 Pantheon, 118-128, Róma

Pantheon, 118-128, Róma





Casa Vettii  
freskó  
Vettiusok  
Háza





72 Vesta templom, I. sz. Róma





73 Pont du Gard, vízvezeték, Kr.e.XV. Nimes



# Forum Romanum rekonstrukció





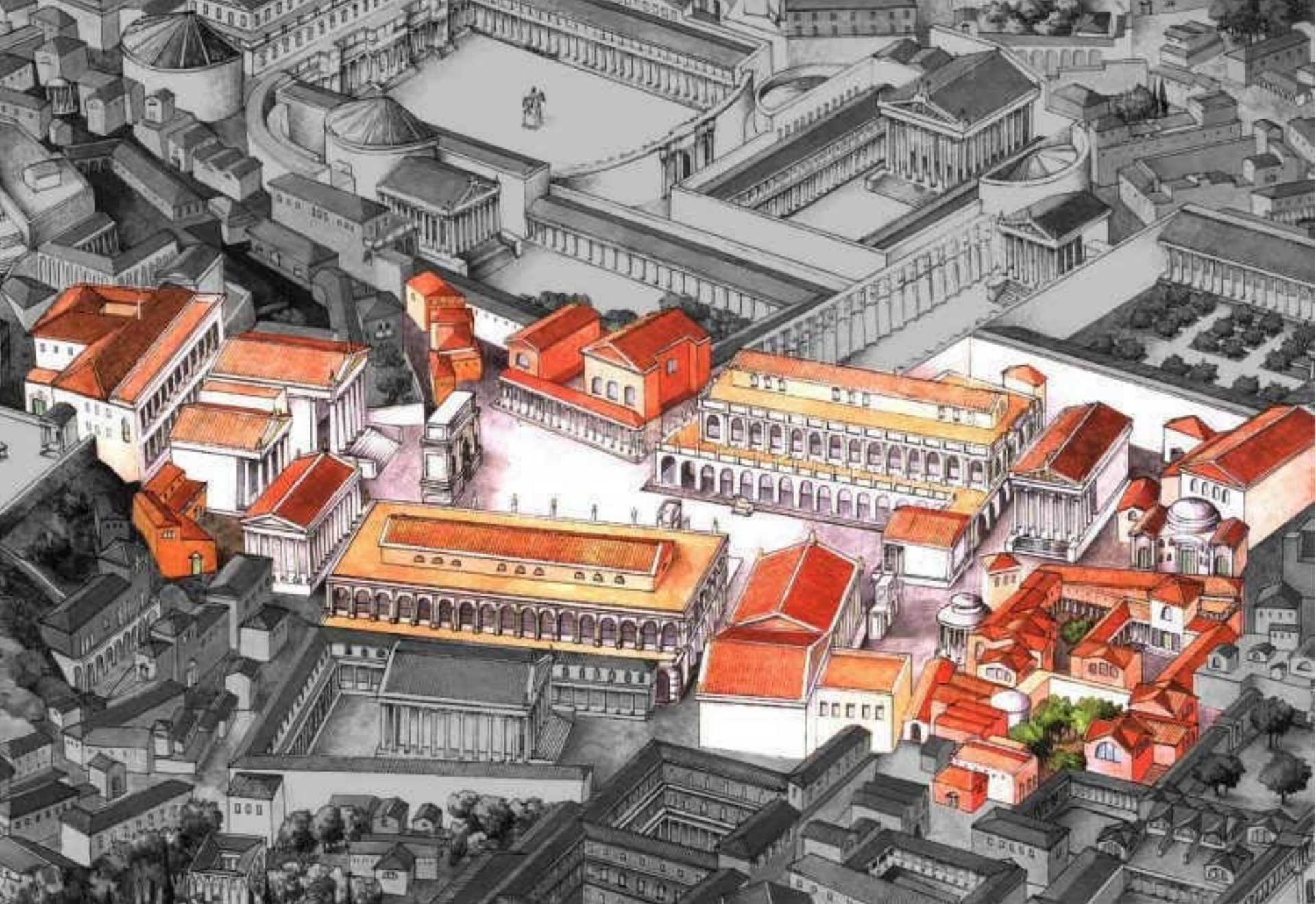

Traianus oszlopa  
110.k. Róma





Constantinus diadalíve, 312-315, Róma



Augustus szobra I.sz.  
Róma, márvány  
eredeti bronz  
Róma, Vatikáni Múzeum





Marcus Aurelius, bronz, lovasszobra, 170, Róma, Muso Capitolino



Caracalla portréja  
Kr.u. 212-215

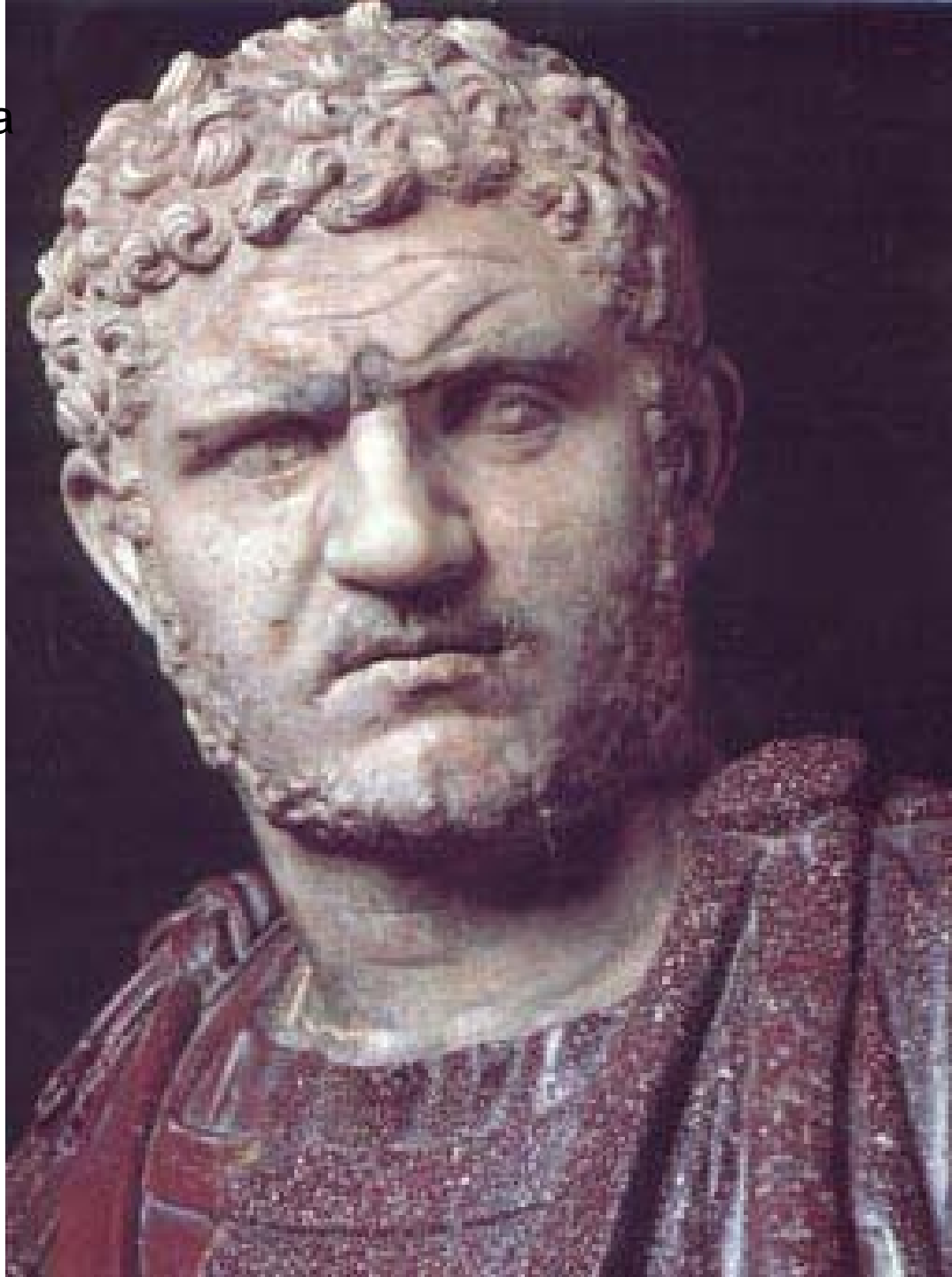



Néro, mellszobra



Szemelé terhessége az első beavatási szertartás  
Misztérium villa freskó, Kr.e.I.sz.







Misztérium villa falfestményei, Pompeji, Kr.e.I.sz. Villa dei Misteri



Szilénosz a szatír és a nímfa, Misztérium Villa, falfestmény, Pompeji  
Ismeretlen mester Kr.e. 60-50

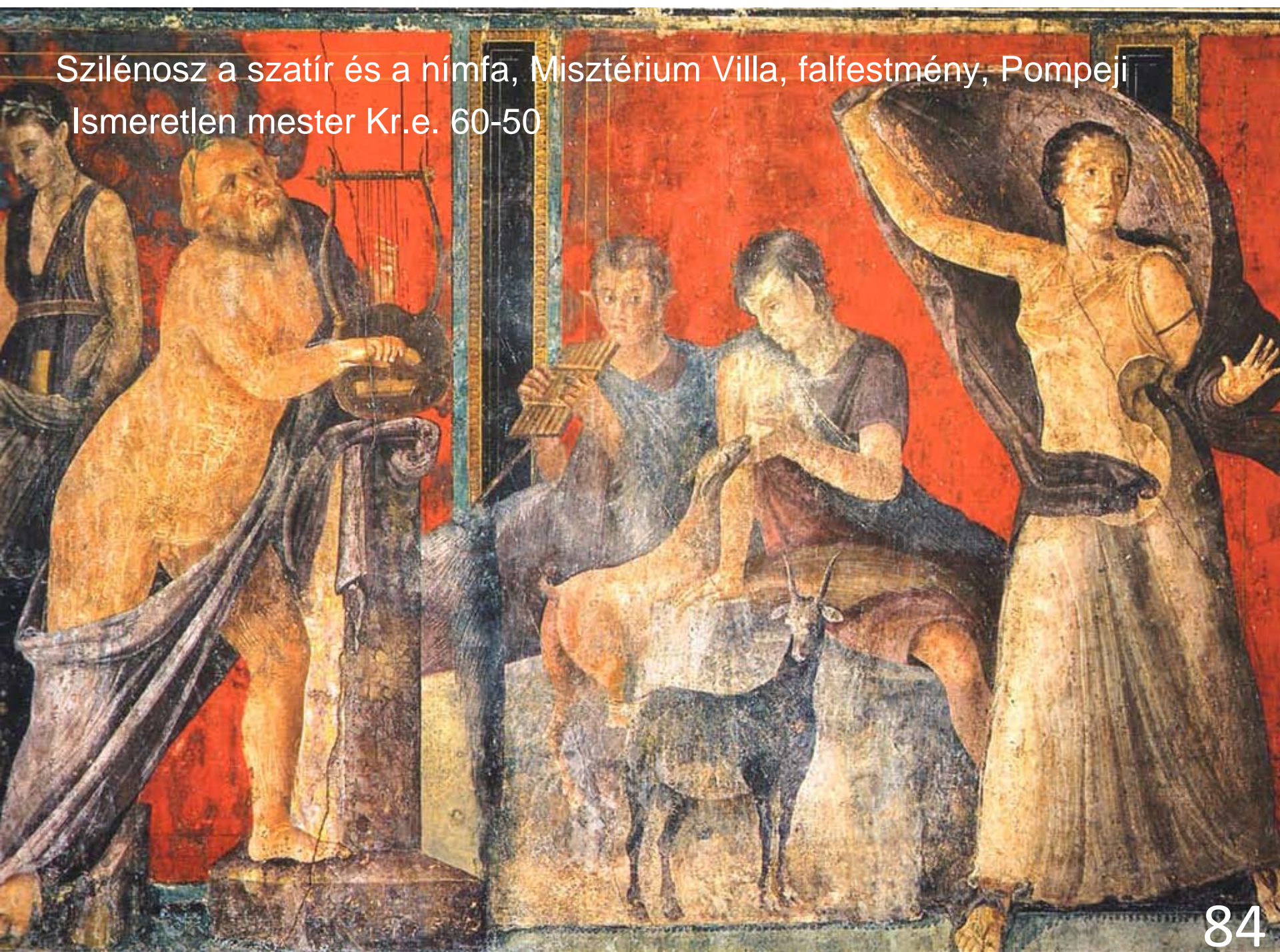









Amfiteátrum kettős színház



# KORA KERESZTÉNY

Jó pásztor  
Priscilla katakomba  
Róma, 3. sz.







89 Santa Sabina, 422-432, Róma



90 San't Apollinare in Classe bazilikája, Ravenna, 549



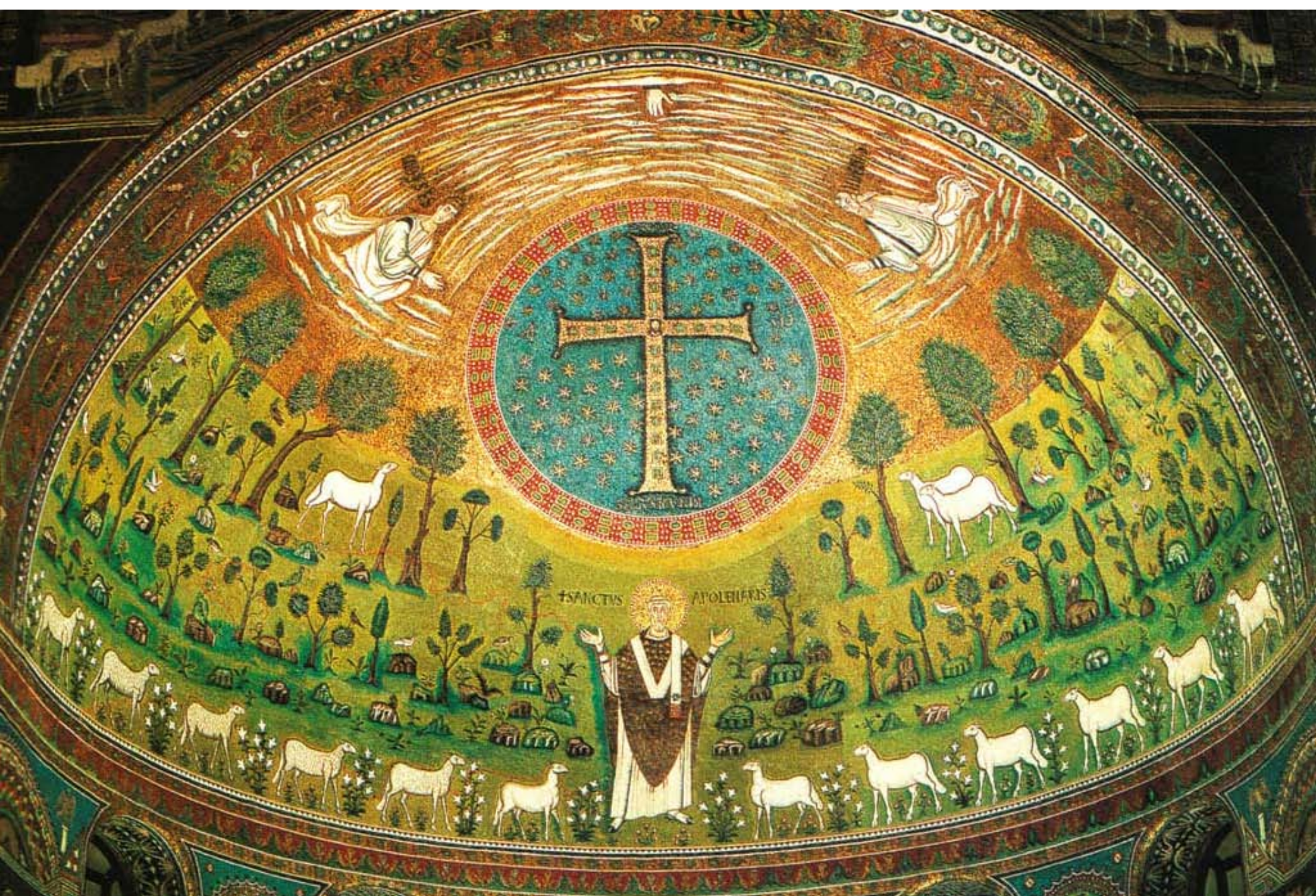

91

Szent Apollinaris és a nyáj, előző templom apszis festmény, 535-549. Ravenna





92 Galla Placidia mauzóleuma, 5. sz, Ravenna



San Vitale  
templom  
532-547  
Ravenna







San Vitale, Krisztus Kozmokrátor és két angyal és Szent Vitus, apszis mozaik, Ravenna





95 Jó pásztor mozaik, V.sz. Ravenna, Galla Placidia





96 Szent Pál bazilika, Róma, itt temették el Szent Pált



Basilica Papale di Santa Maria Maggiore  
Szűz Máriáról elnevezett legnagyobb  
katolikus templom Rómában





Isd. előző





Maximianus püspök trónja fa és elefántcsont 550  
Ravenna  
Érseki Múzeum







100 Háromkirályok, mozaik, 550, Ravenna, San Apollinare Nuovo



Jézus Pilátus előtt  
Rossanoi Codex  
Purpureus lapja  
VI. sz.  
Rossano katedrális







102 Szentek menete, San Apollinare Nuovo, 560, Ravenna, főhajó déli oldala



Durrowi Kódex

7. sz.

Kellsi Kódex

8. sz.

Dublin

Trinity College







# NÉPVÁNDORLÁS

Galgóci tarsolylemez

X.sz.

MNM





Nagyszentmiklósi kincs

800

Bécs, Kunsthistorisches M.



Sankt gelleni  
kolostor tervrajz  
830  
Sankt Gallen  
Könyvtár

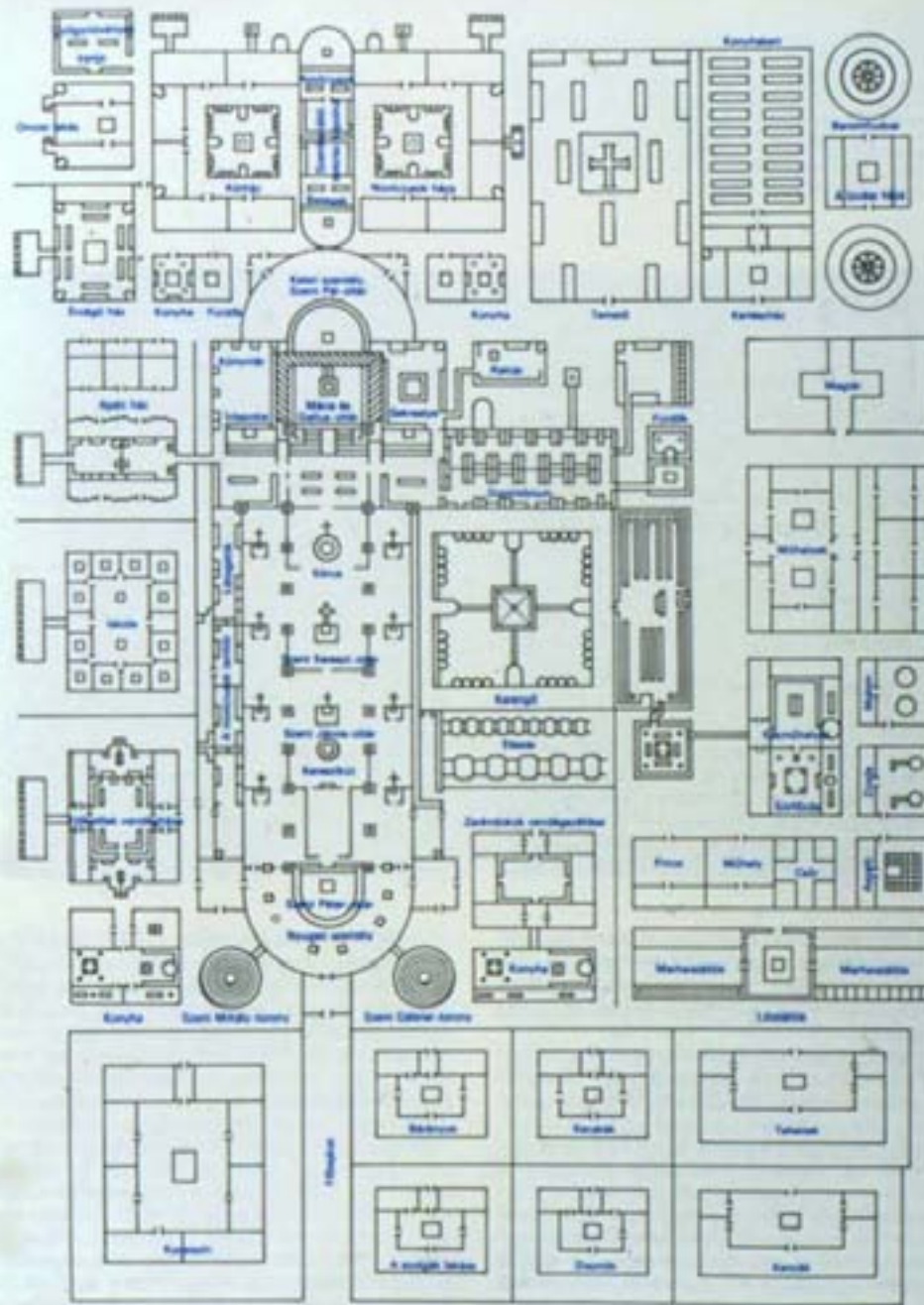

A Sankt Gallen-i kolostor alaprajza egy 820 körül készült rajz alapján (Svájc)



Szarmata korongos  
fibula, III. sz.  
MNM



Germán sasfibula, VI. sz. Nürnberg, Germanisches Nationalmuseum





Avar szíjvég pl. klárafalvi, Szeged, Móra Ferenc Múzeum





**112** Fejedelmi szablya markolata, Attila kard, X. sz. Bécs, Schatzkammer



László Gyula rajza, Honfoglaló magyarok öltözete



Honfoglaló magyarok öltözete  
László Gyula rajza





BIZÁNC

# Hagia Sophia, VI.sz. Konstantinápoly







117 San Vitale 532-547



San Vitale mozaikja, Justinianus császár és kísérete, 574, Ravenna





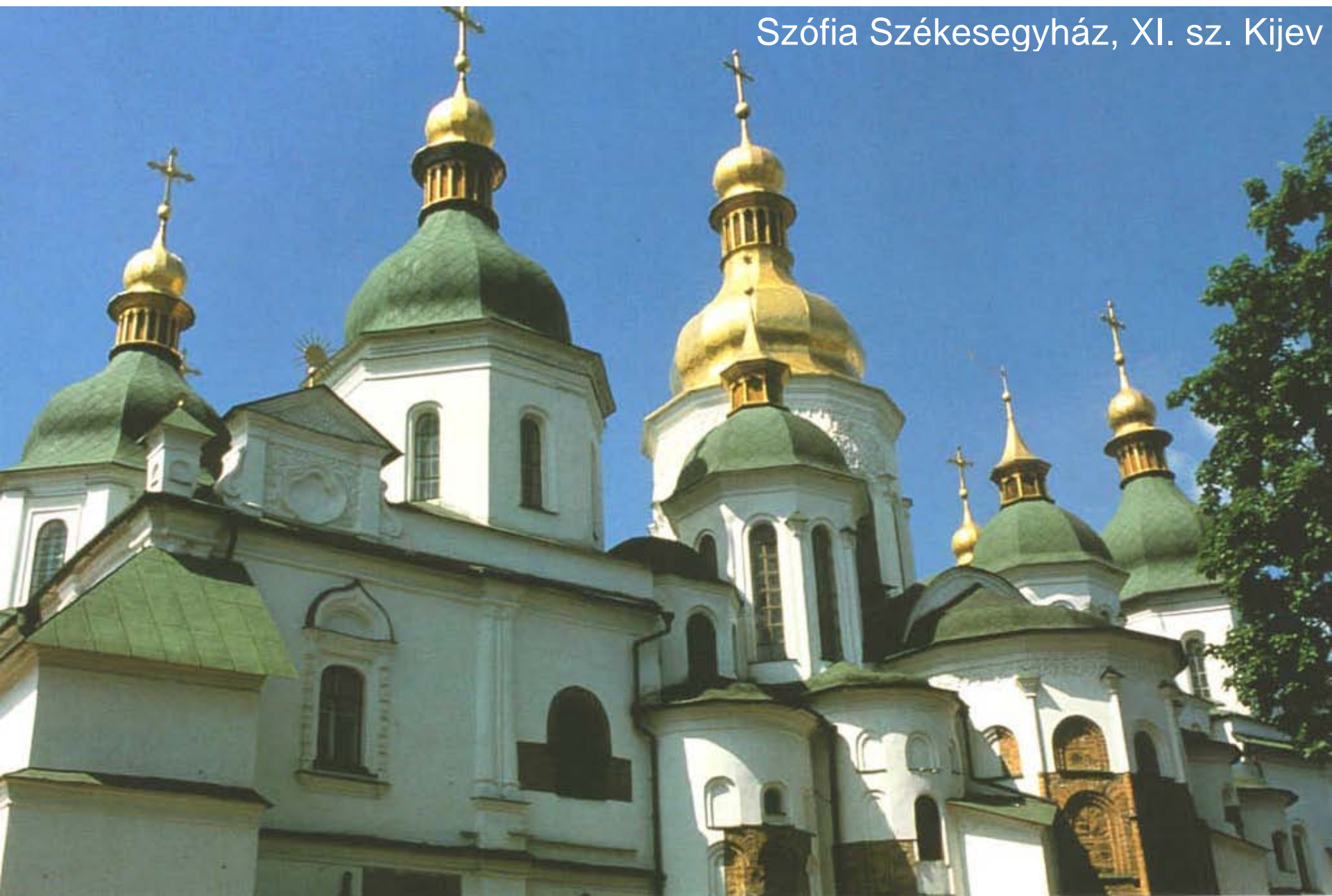

Krisztus és  
Abu Menas  
ikon, VI. sz  
Párizs, Louvre





Nikopeia Istenanya

10.sz Velence

Szent Márk

Székesegyház



Istenanya gyermek  
Jézussal és két  
angyallal 13.sz  
tempera, fára  
Washington  
National Gallery of  
Art





Andrej Rubljov:  
Szentháromság,  
Troica  
1430 tempera  
Moszkva  
Tertyakov Képtár



Szaurotéka  
ereklyetartó





Szaurotéka

X.sz

Limburg,

Székesegyházi

Kincstár



ROMANIKA



Akeni Dóm  
Paltskapel



Maria Laach bencés főtemplom, XI-XIII.sz Koblenz mellett





Pisai dóm, XI-XIII.sz



# Pontigny-i ciszterci templom, 1140-1170





Szt. Mihály  
templom, 1033.  
Hildesheim



Szent Mihály templom

131

Hildesheim, 1033



Szent Mihály templom  
1033 Hildesheim





Bencés apátsági templom, XIII.sz

Ják



Bencés apátsági templom, XIII.sz, Ják





Ciszterci templom, XIII.sz. Bélapátfalva



Csempeszkopácsi plébániatemplom, XIII.sz







137 Szent István szarkofágja XI.sz, Székesfehérvár, István Király Múzeum





Háromkirályok  
dombormű XII.sz  
Pisai dóm  
bronzkapuján

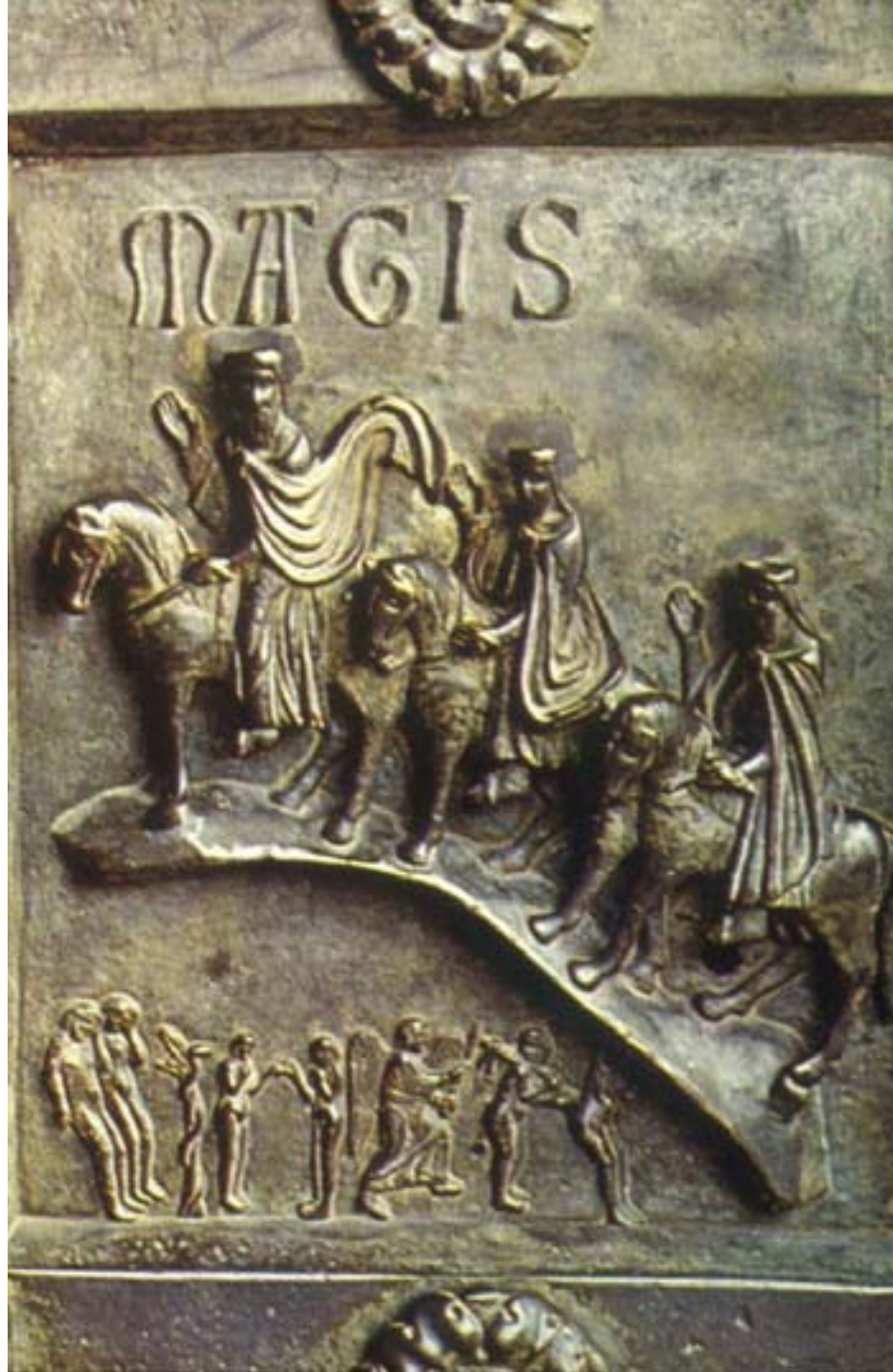

Maistas Domini  
1123  
Clemente apszis  
Barcelona,  
Katalán Múzeum





Koronázási palást  
XI.sz  
MNM



Bayeux-i kárpit, 1080, Bayeux, Bibliothèque Municipale





Szent Korona  
XI-XIII.sz  
Parlament



Királyfej Kalocsáról

XIII.sz

MNG



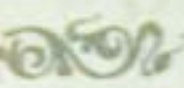

Winchesteri biblia  
H iniciálé  
1150-1160  
Winchester  
Cathedral Library

INCIPIIT LIBER ELLES  
MOTH. QVI GREEDI  
CITUR EXODUS: 



GÓTIKA



Notre Dame, 1163-1250  
Párizs

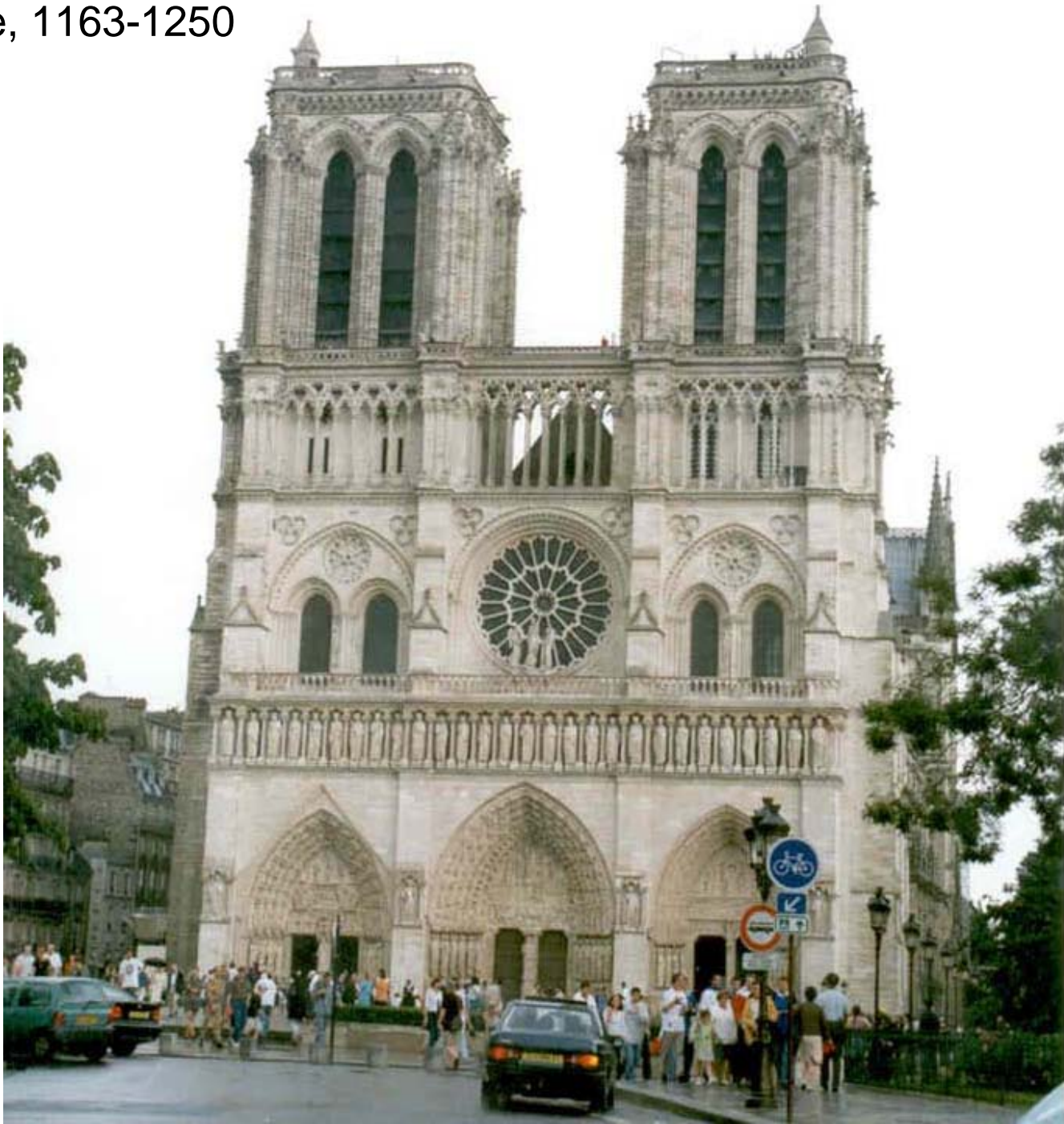



148 Amiens-i székesegyház 1236-1389



Amiens-i székesegyház  
1236-1389



Chartres-i székesegyház

1194-1220



150



Ca d'Oro palota

XV. sz

Velence









Westminster Abbey  
1065



153



154 Cambridge-i King's College Chapel 1446-1515



Cambridge-i  
King's Chapel  
College  
1446-1515



Szent Vitus  
székesegyház  
XIV.sz  
Prága





Szent Vitus  
székesegyház  
XIV.sz  
Prága



Nyírbátori  
református  
templom  
XV.sz





Veleméri templom XIV.sz



Nagyboldogasszony  
templom







**161** Vajdahunyad vár, XV.sz, Vajdahunyad

Kassai  
Szent Erzsébet  
templom  
déli kapuja





Utolsó ítélet  
Kassa  
Szent Erzsébet  
templom északi  
kapuja, XV.sz



Uta és Ekkhard, 1250  
Naumburg dóm





Veit Stoss:  
Mária oltár  
1477-1483  
Mária templom  
Krakkó



Kolozsvári Márton  
és György:  
Szent György  
bronz szobor  
1373. Prága  
Národni Galeri





Chartres-i  
katedrális üveg-  
ablakai, XIII.sz  
Mária halála



Cimabue: Trónoló Madonna  
XIII.sz. Firenze, Uffizi





Duccio: Maesta 12.sz. Siena főoltár, selyemzászló





Ambrogio Lorenzetti: Kinyilatkoztatás, 1344. Siena

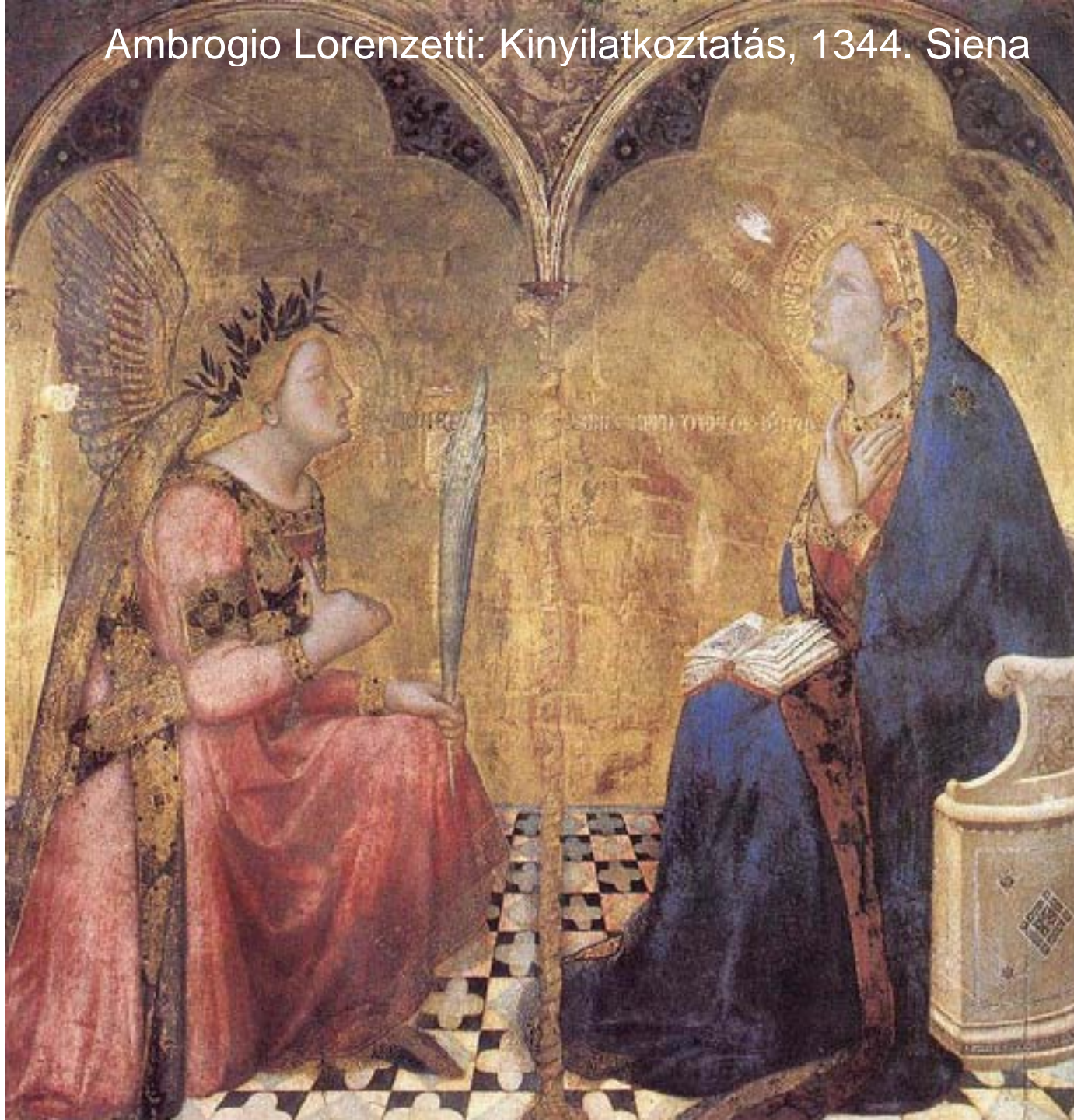



Giotto: A szűz születése





Giotto: Szent Anna látomása freskó a padovai Scrovegni kápolnából





Giotto: Jézus siratása, 1304-1306- Padova, Capella dell'Arena



Simone Martini, Lippo Memmi: Angyali üdvözlet, 1323.  
Uffizi, Firenze





Kolozsvári Tamás  
Kálvária 1427  
Esztergom  
Keresztény  
Múzeum

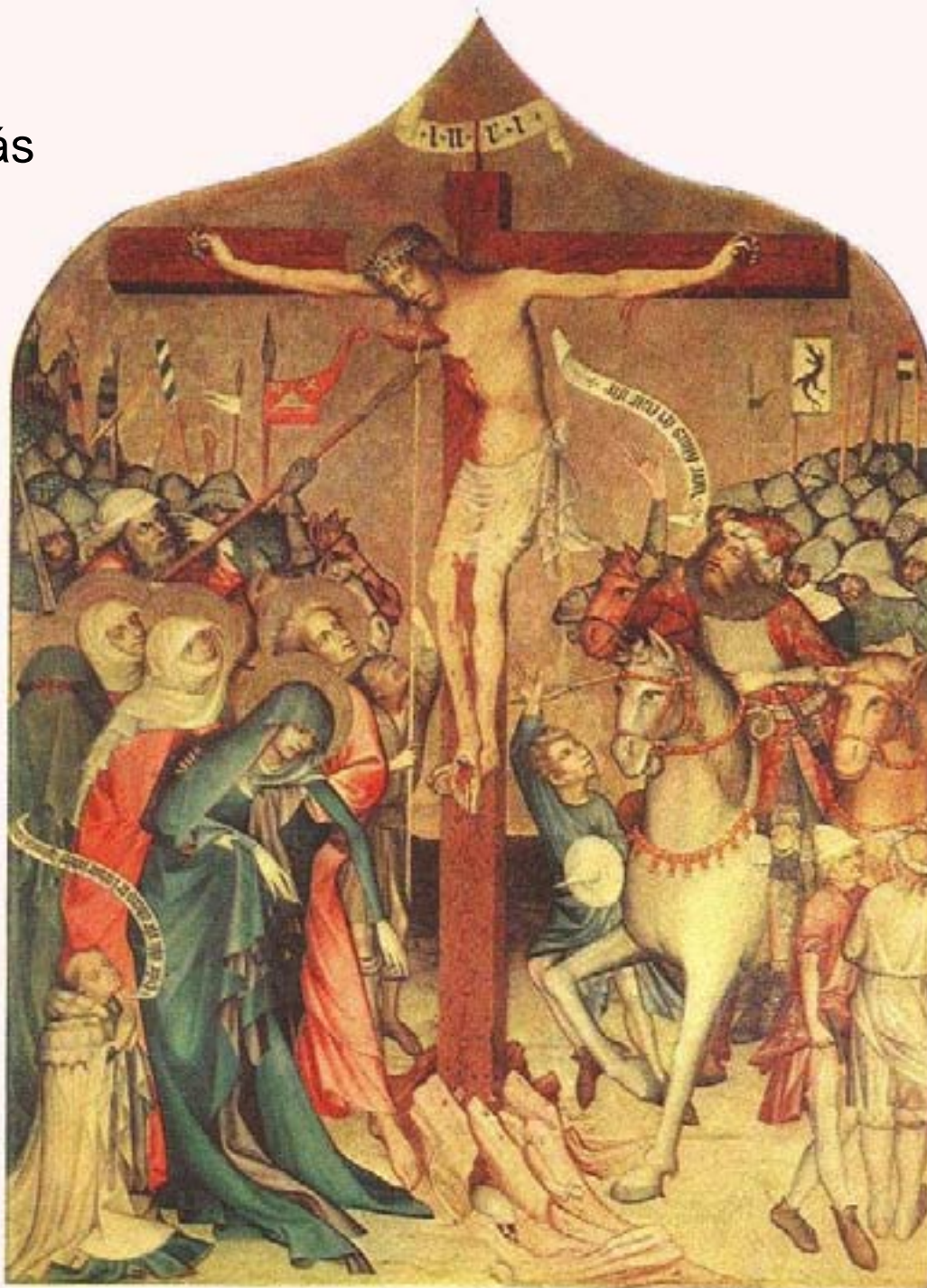

M.S. Mester: Mária és Erzsébet találkozása 1508. MNG  
selmecebányai oltárkép





M.S.Mester:

Kálvária

1500-10

Tempera

Esztergom

Keresztény Múzeum



Lócsei Pál: Szent  
Jakab templom  
főoltára 1508-1517





Lőcsei Pál: Szent  
Jakab templom  
főoltára 1508-1517





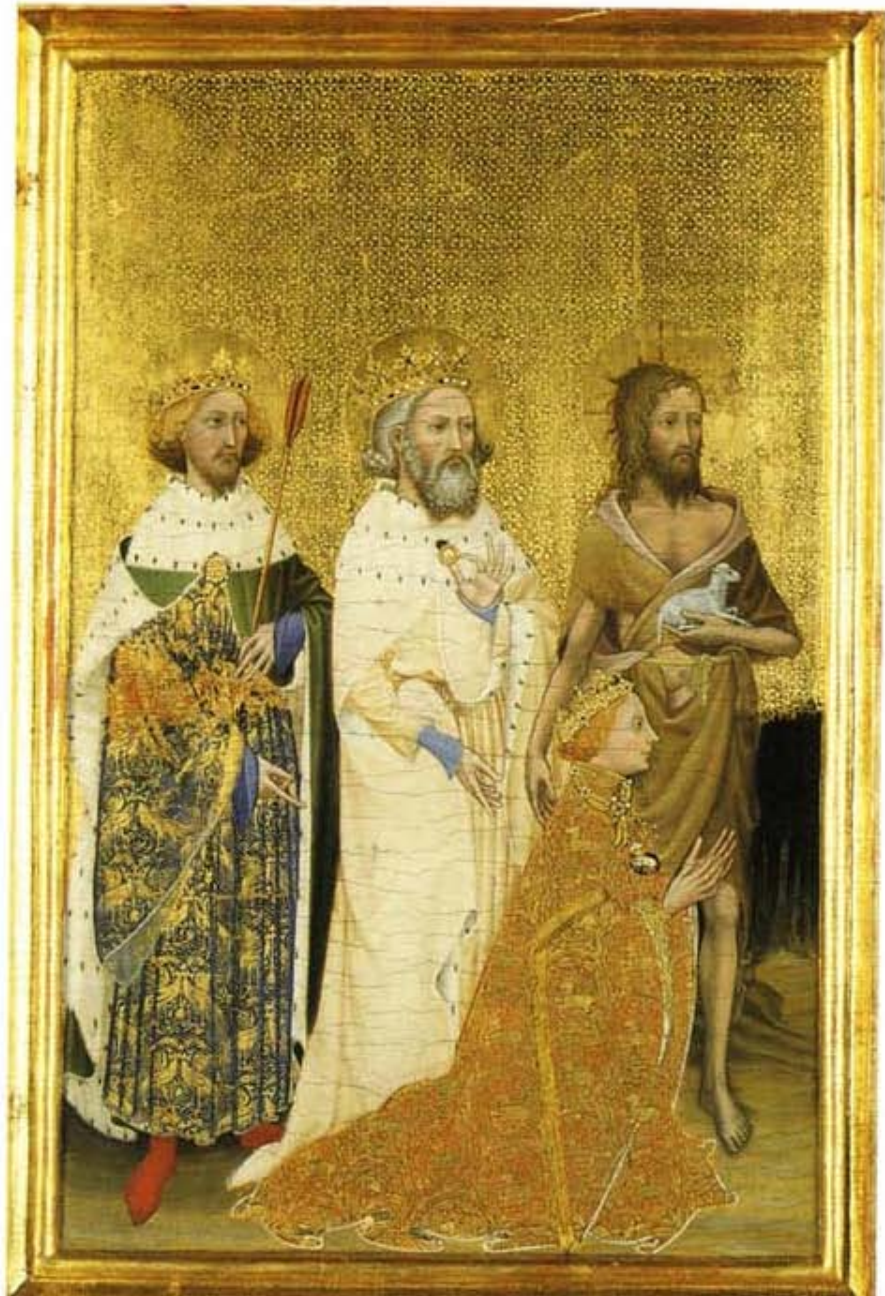

180 Wilton diptych, 1400, London National



Avignoni Pietá, XV.sz Párizs, Louvre



Limbourg fivérek:  
Május, Berry herceg  
hóráskönyvéből





Magyar Anjou  
Legendárium  
XIV.sz



Képes Krónika

1360

OSZK





Szent László  
fej ereklyetartó  
1425  
Győr  
Székesegyház



Suki kehely  
XV.sz közepe  
Esztergom  
Főszékesegyházi  
Kincstár





Az egyszarvú legendája, goblein sorozat, Párizs, Musée Cluny

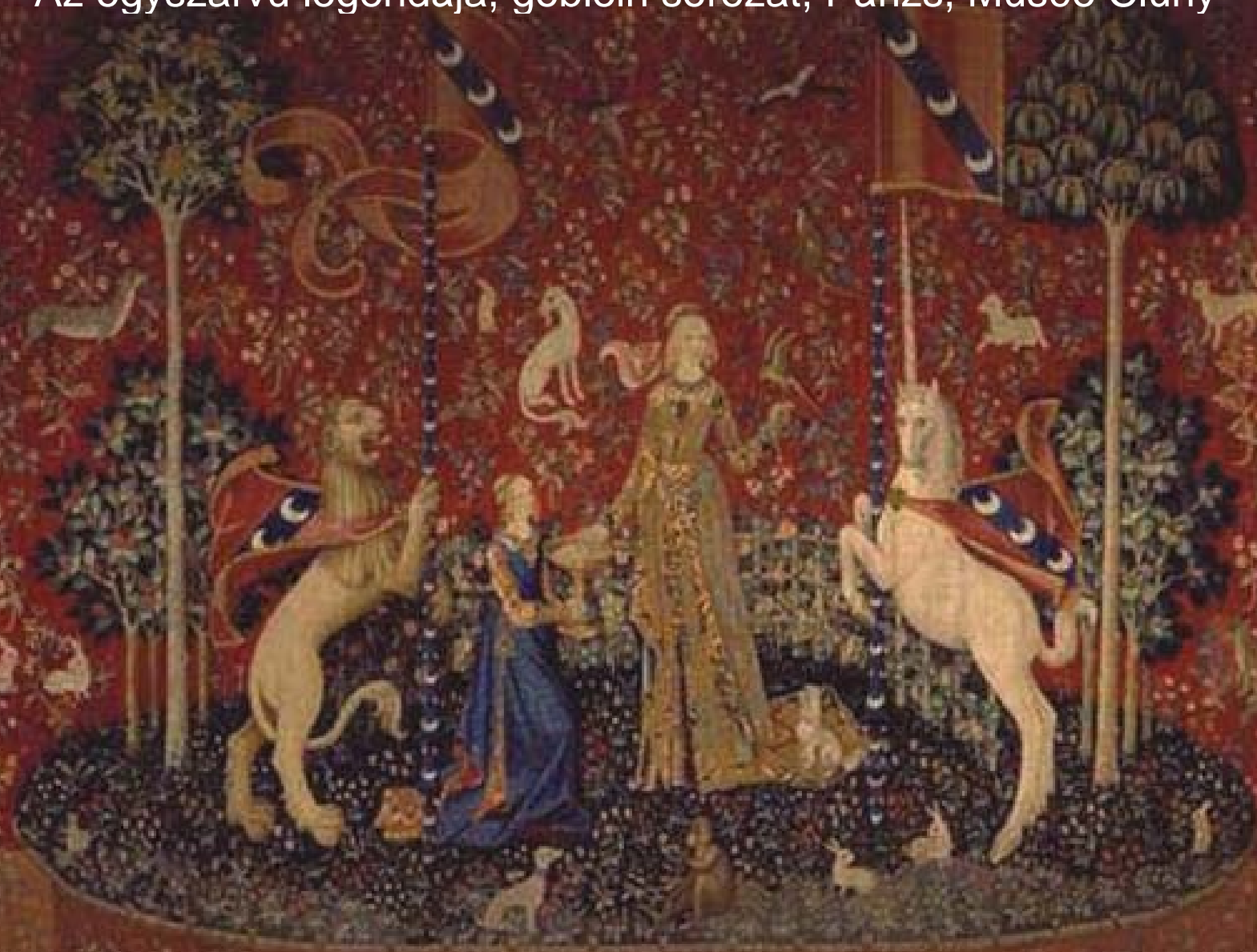

Szent László  
legendája  
1420  
Kakaslomnic





pl. Baldovierik esküvői edénye, Murano Üveg múzeum



Muráni üvegtárgy XV.sz

RENEZÁNSZ



Santa Maria de Fiore 1296-1436. Firenze







Benedetto da Maiano Cronaca  
Palazzo Strozzi 1498-1508  
Firenze



Donato Bramante:  
Tempietto  
1502-1505 Róma  
San Pietro in  
Montorio kolostor

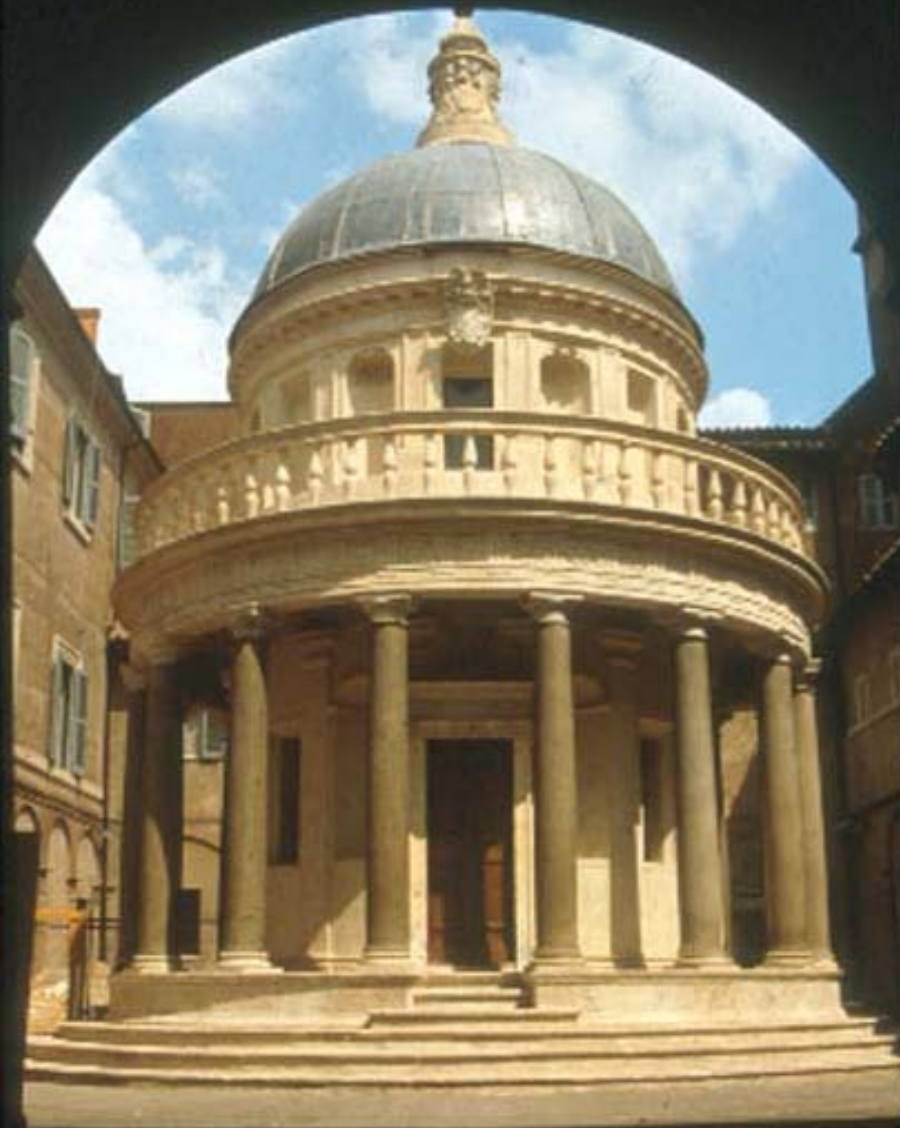





195 Andrea Palladio: Villa Rotonda, 1550 u. Vicenza





Szent Péter bazilika, Róma



Egy Loire menti reneszánsz kastély, Chenanceaux, Chambord vagy Blois







Egy Loire menti reneszánsz kastély, Chenonceaux, Chambord vagy Blois



Egy Loire menti reneszánsz kastély, Chenanceaux, Chambord vagy Blois



Vaszilij  
Blazsennij  
székesegyház  
XVI.sz  
Moszkva





202 Budai vár és királyi palota, XIV-XVI.sz. és XVIII.sz és XIX-XX.sz.



Budai vár és királyi palota, XIV-XVI.sz. és XVIII.sz és XIX-XX.sz.





Budai vár és királyi palota, XIV-XVI.sz. és XVIII.sz és XIX-XX.sz.





Visegrádi királyi  
palota XIV-XV.sz



Bakócz-kápolna  
1506-1507  
Esztergom

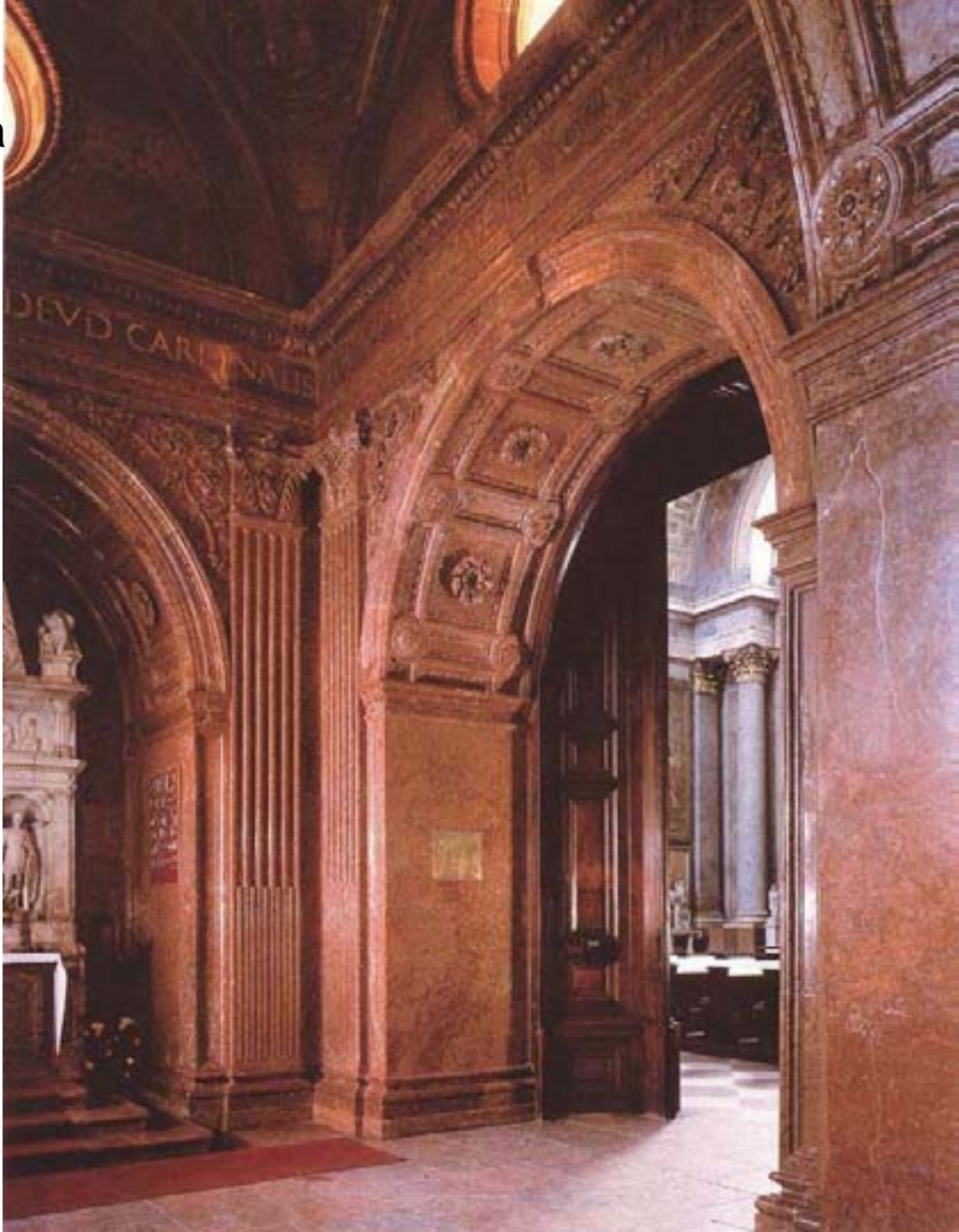



Bakócz-kápolna  
1506-1507  
Esztergom





Sárospataki vár, XVI-XVII.sz





Nicola Pisano  
keresztelőkápolna  
1260, Pisa



Lorenzo Ghilberti: A firenzei Battistero bronzkapuja, Porta del Paradiso 1430.

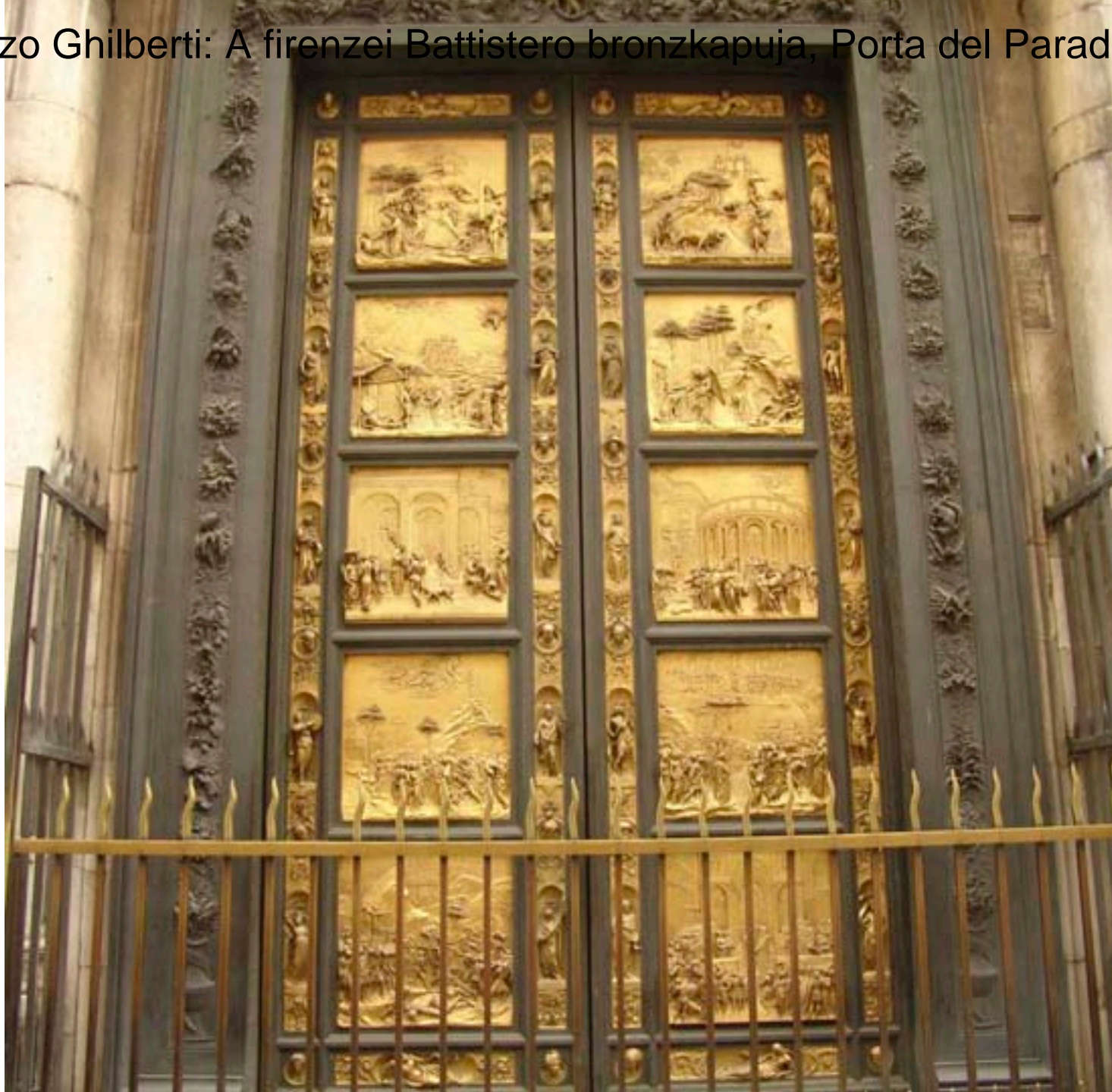



Lorenzo Ghilberti: A firenzei Battistero bronzkapuja, Porta del Paradiso 1430.





Lorenzo Ghilberti: A firenzei Battistero bronzkapuja, Porta del Paradiso 1430.





Donatello Gattamelata lovasszobra, bronz, 1447-1453. Padova





Andrea del  
Verocchio:  
Colleoni  
zsoldosvezér  
lovasszobra,  
1480. Velence







215 Michelangelo: Pietá, 1498. márvány, Róma, San Pietro

Michelangelo:  
Dávid 1504.  
Firenze  
Accademia







Michelangelo: Mózes, II. Gyula pápa síremléke, San Pietro in Vincoli bazilika, Róma

Michelangelo:  
Lorenzo Medici  
síremléke 1525.  
Firenze,  
San Lorenzo  
templom sekrestyéje





Donatello: Dávid  
1430-1435  
Firenze,  
Musio Nazionale





220 Visegrádi Madonna, 1480. Visegrád, Mátyás Király Múzeum



Massaccio:

Szentháromság freskó

1427

Firenze

Santa Maria Novella

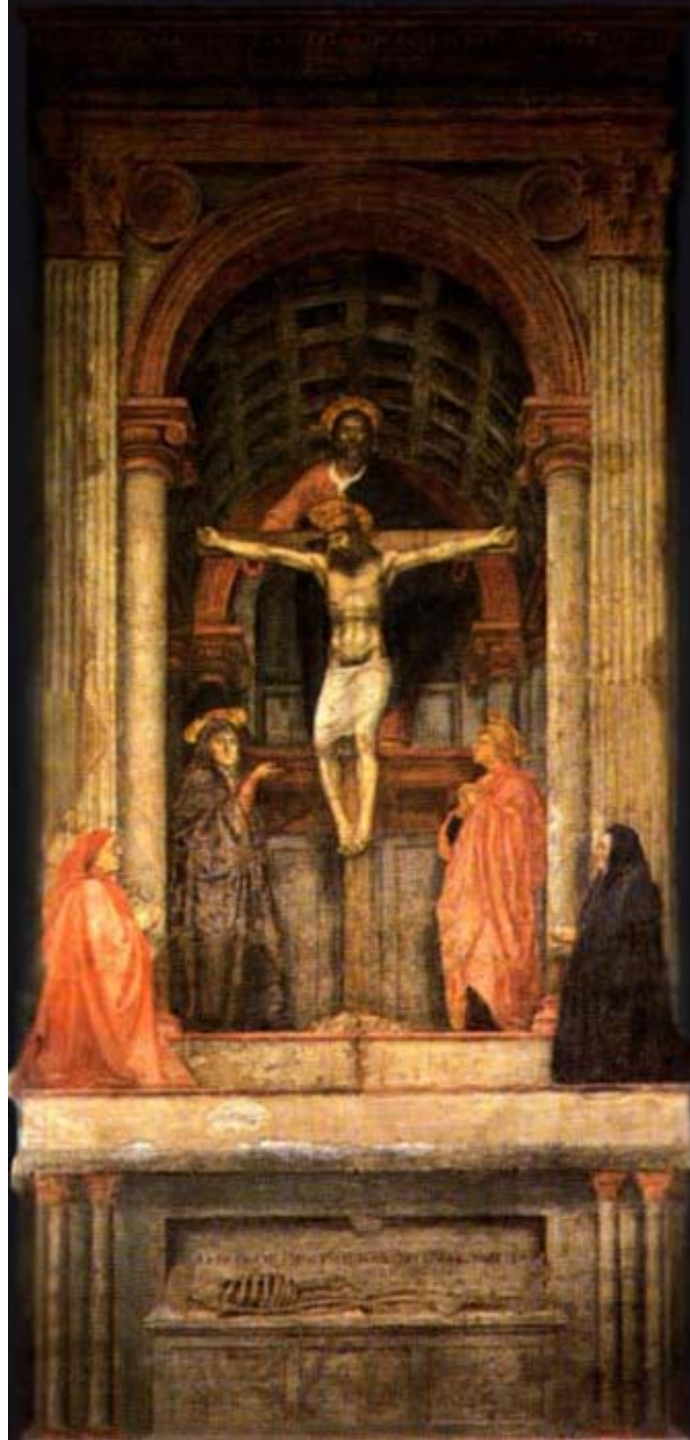

Fra Angelico: Krisztus levétele a keresztről

1437-1440

Firenze

Museo San Marco





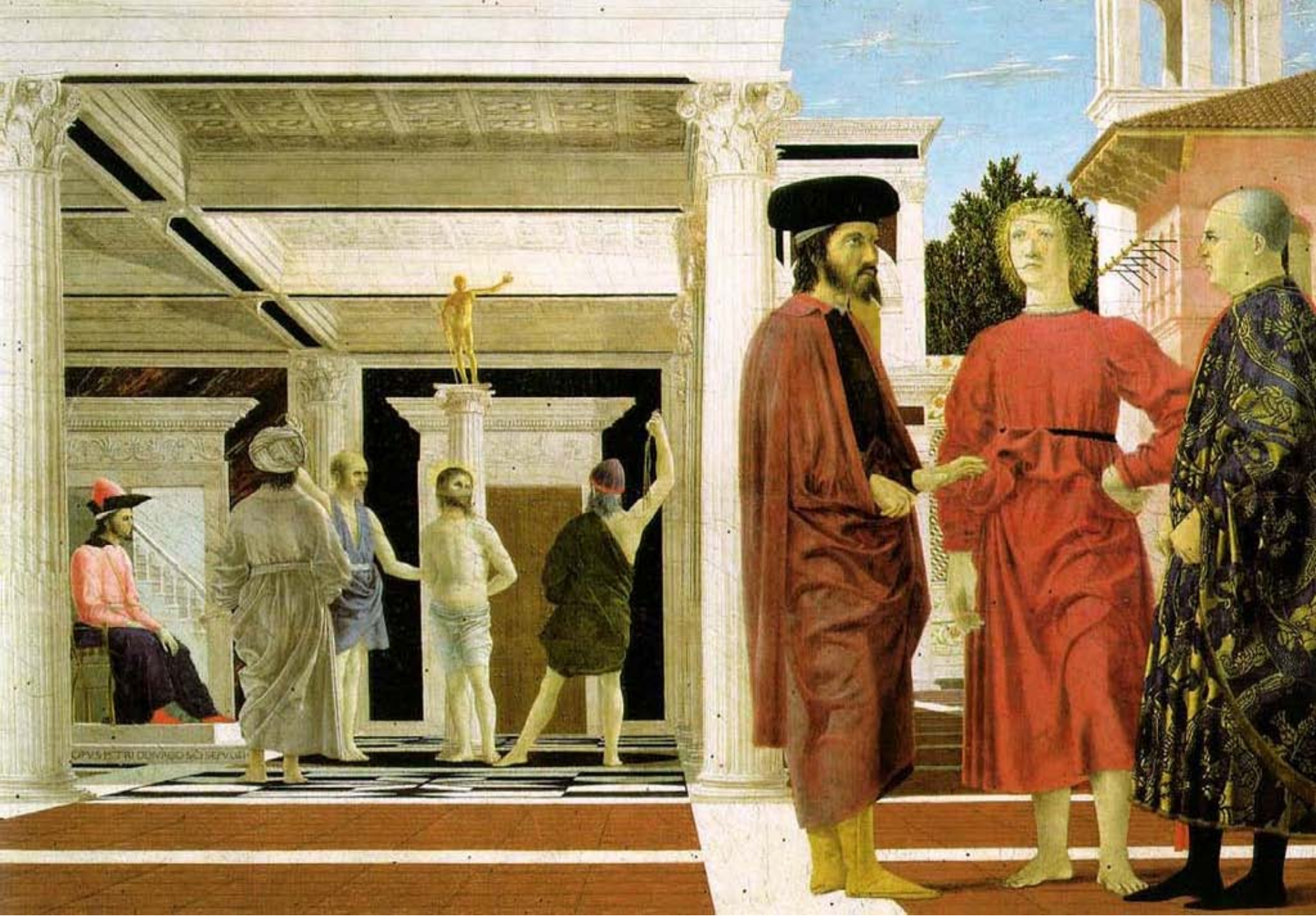

223 Piero della Francesca: Krisztus ostromozása, Urbino, Palazzo Ducale



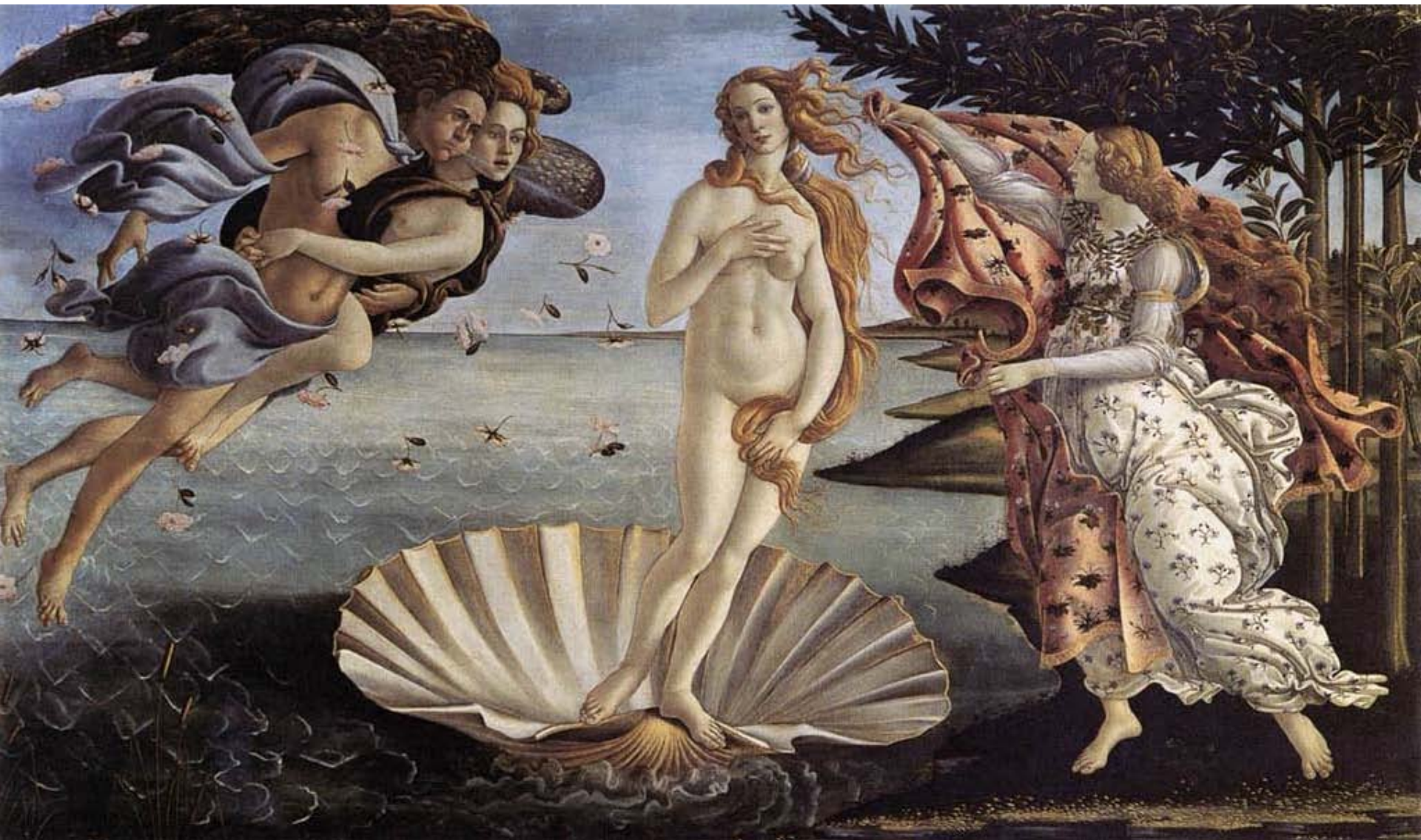

224 Sandro Botticelli: Vénusz születése 1485. Firenze, Uffizi



Carlo Crivelli:  
Angyali üdvözlet  
1486.London  
National Gallery







226 Andrea Mantegna: Pietá, 1506. Milánó, Brera





Leonardo da Vinci: Utolsó vacsora, 1495-1497. Milánó, Santa Maria delle

Grazie kolostor refektóriumában

da Vinci:  
Szent Anna  
harmadmagával  
1498.  
London  
National Gallery





da Vinci:  
Mona Lisa  
1503-1505  
Párizs, Louvre



da Vinci:  
Vázlatok az  
emberalak tanul-  
mányozásához

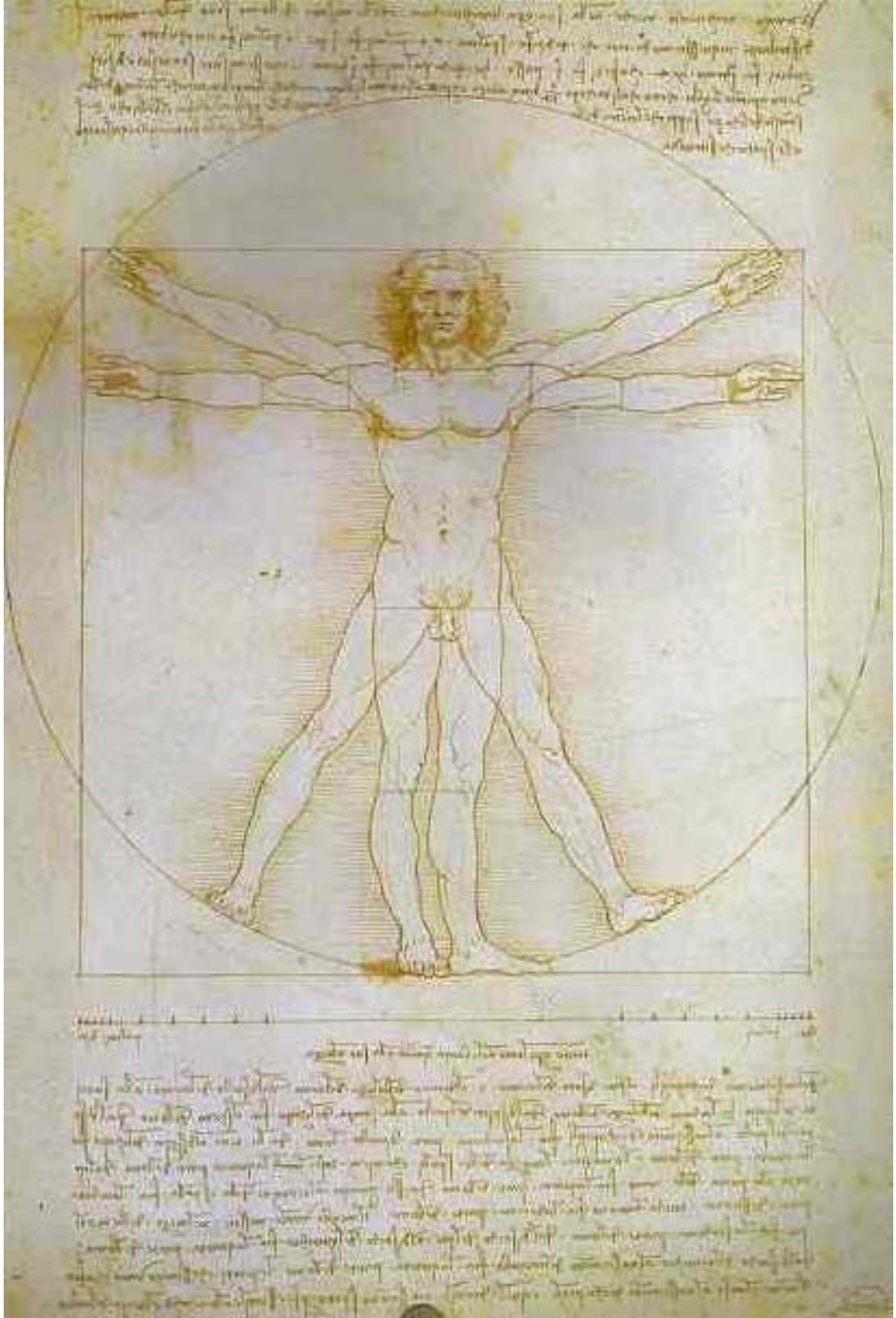



Raffaello Santi: Esterházy Madonna 1507-1508. Budapest, Szépmű





Raffaello: Arhéni iskola, freskó, 1509-1510. Vatikán, Stanza della Signatura

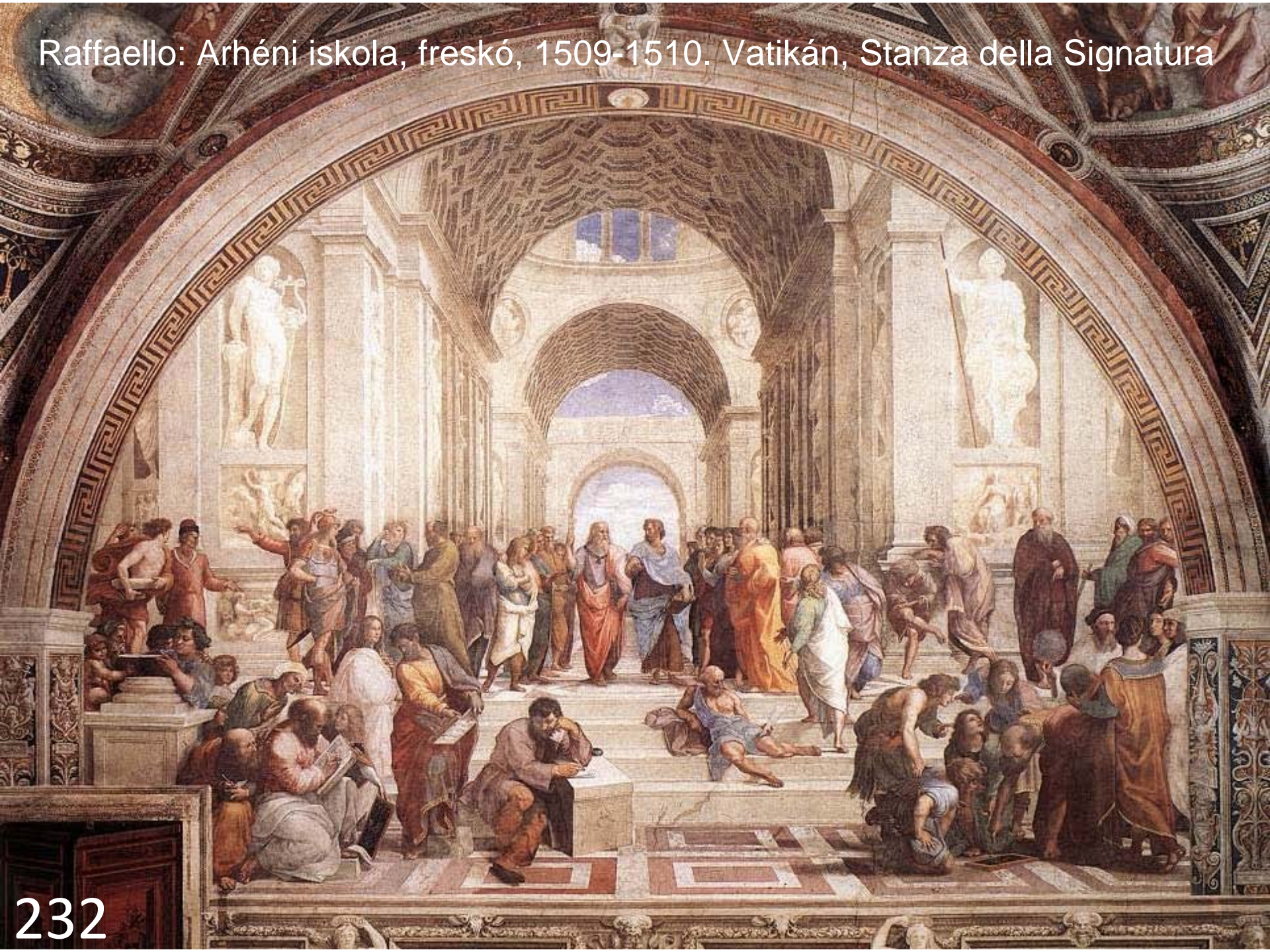



Raffaello:  
Egy fiatal nő  
portréja  
La fornaira  
1520

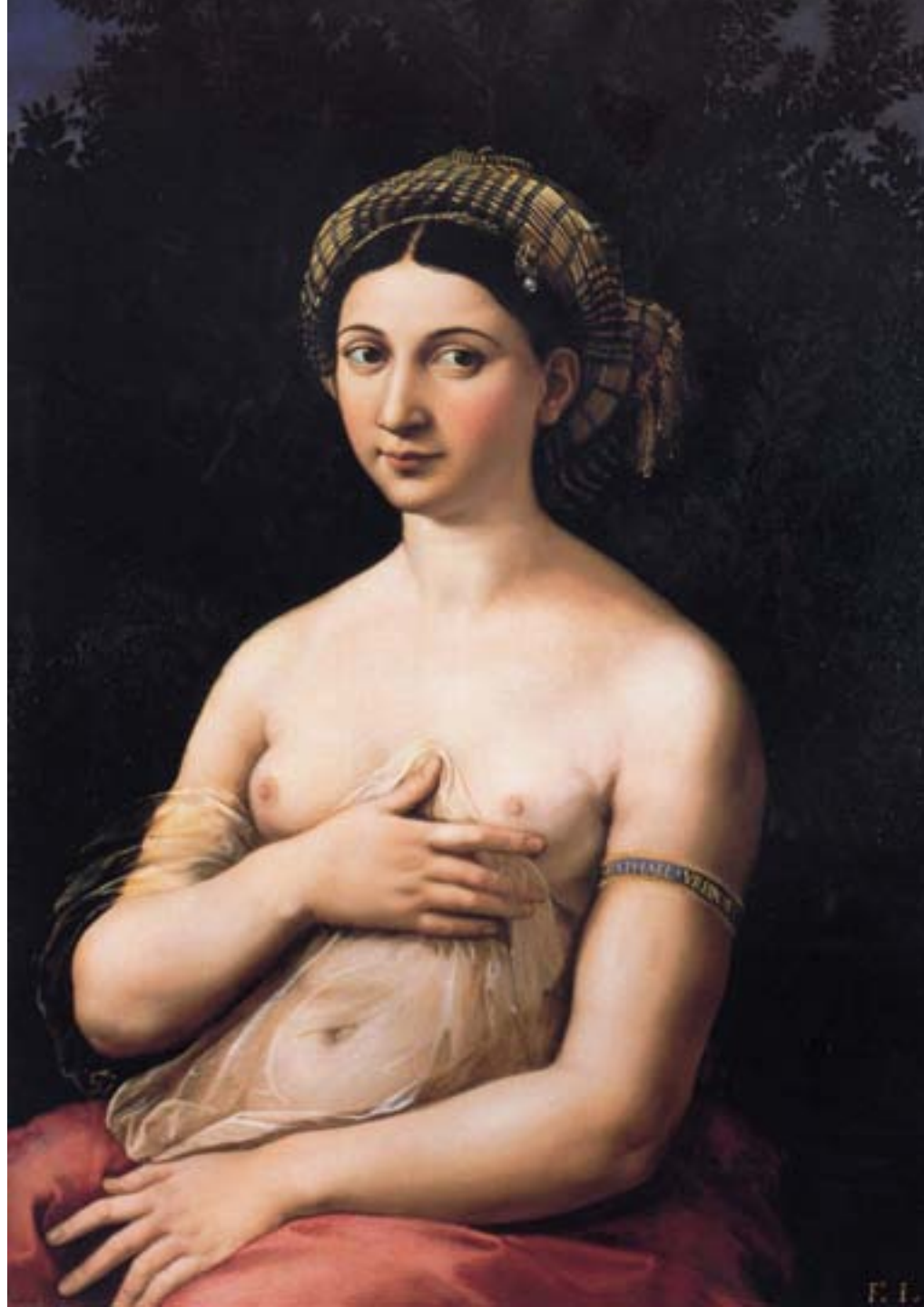

Michelangelo:  
Utolsó ítélet,  
freskó  
1537-1541  
Vatikán  
Capella  
Sistina





Giorgione:  
A vihar,  
1506.  
Velenca  
Accademia





236 Tiziano Vecellio: Urbinói Vénusz, 1538. Firenze, Uffizi





237 Benvenuto Cellini: Sótartó, 1543. Bécs, Hofmuseum



238 Nyírbátori stallum, 1511. MNM



Jan Van Eyck:  
Arnolfini házaspár  
1433. London  
National Gallery





240 Jan van Eyck: The Adoration of the Lamb, 1432. The Ghent Altarpiece





241 Rogier van der Weyden: Angyali üdvözlet, Párizs, Louvre



242 Hugo van der Goes: Portinari oltár, 1475. Firenze, Uffizi





243 Hugo van der Goes: Portinari oltár, 1475. Firenze, Uffizi

Bosch:  
Szénásszekér  
1480-1485  
Madrid  
Prado





Albrecht  
Dürer:  
Önarckép,  
1498,  
Madrid, Prado



Dürer:  
Melankólia,  
rézmetszet,  
1514.  
Berlin, Staatliche  
Museen





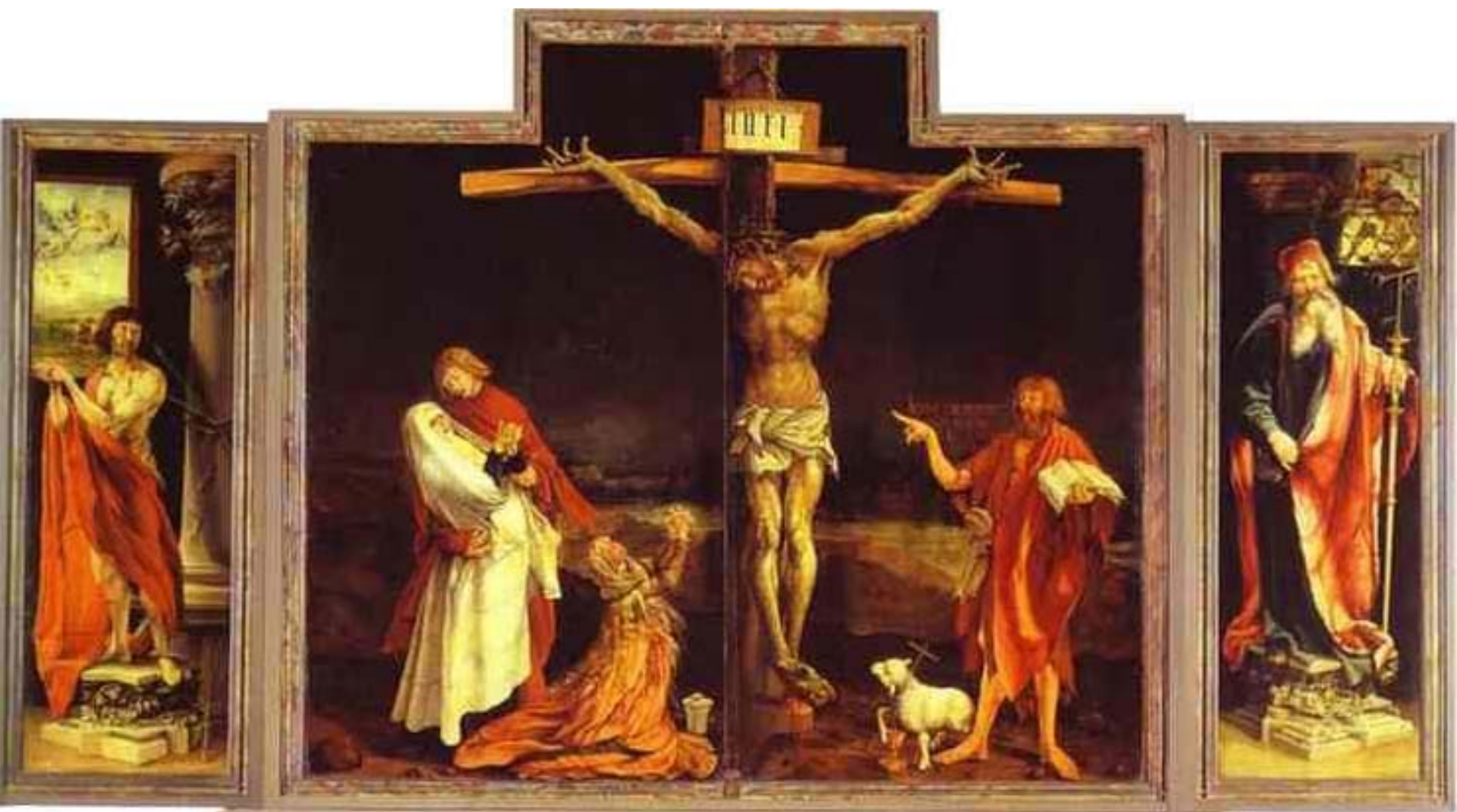

Mathias Grünewald: Keresztrefeszítés az isenheimi oltárról, 1515. Colmar, Múz.





Hans Holbein: Jean de Dinteville és Georges de Selve francia követek képmása, 1533. London, NG





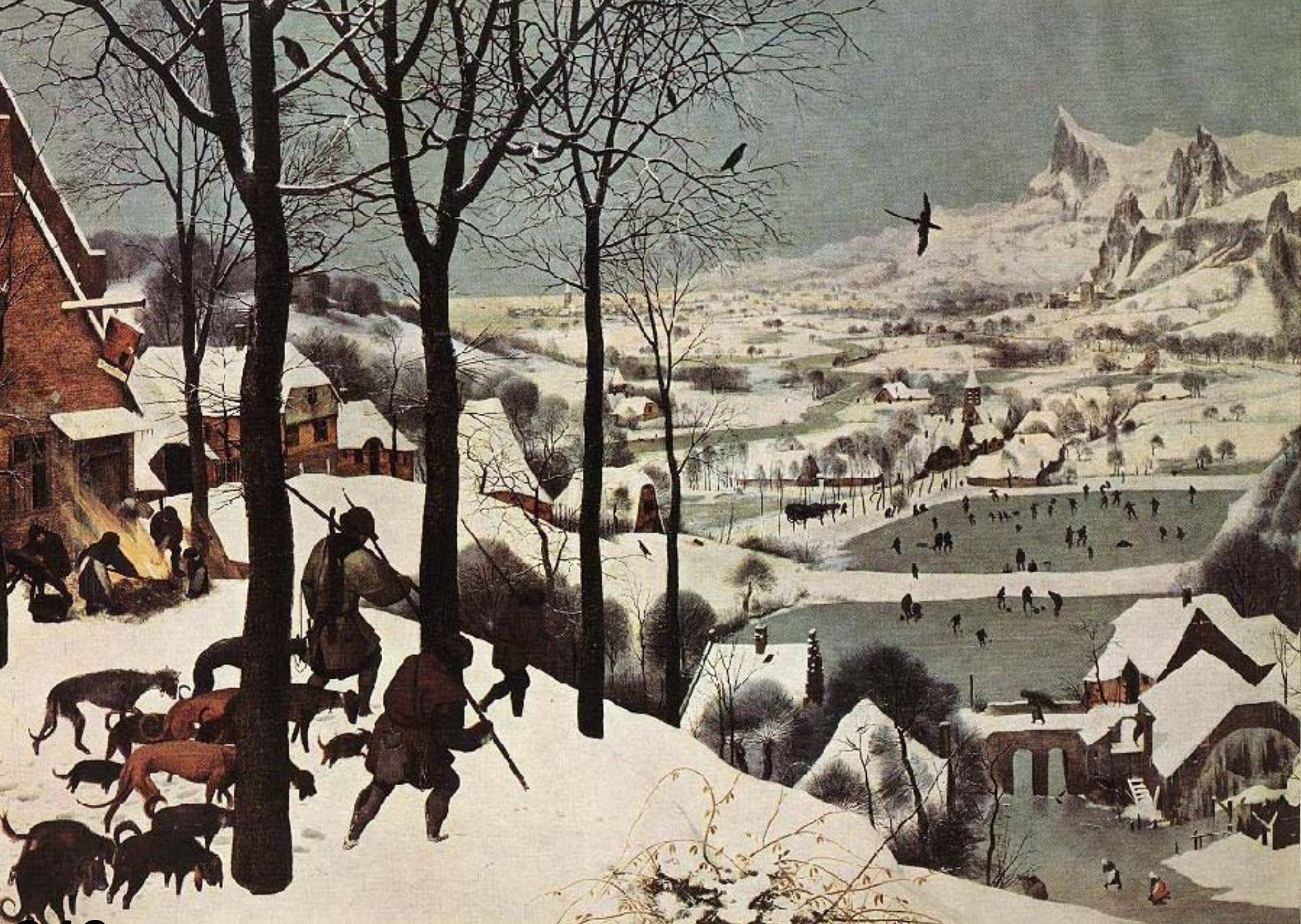

249 Id. Pieter Bruegel: Téli vadászat, 1565. Bécs, Kunsthistorisches Museum





250 Id. Pieter Bruegel: Parasztlakodalom, 1567. Bécs, Kunsthistorisches M.





251 Jacopo Tintoretto: Bachus, Venus és Ariadné, 1578.



Paolo Veronese: Lakoma Lévi házában, 1573.

Velence, Akadémiai Képtár



El Greco:  
Oraz gróf  
temetése  
1586.  
Santo Tome,  
Toledo



El Greco:  
Krisztus az  
olajfák hegyén  
1579.  
SZM





Angelo  
Bronzino:  
Toledói Eleonóra  
XVI.sz. vége  
Firenze, Uffizi



**BAROKK**



Giacomo della  
Porta:  
Il Gesú homlokzata  
XVI.sz vége  
Róma





Bernini: Szent Péter tér, 1656., Róma





Bernini: Szent Péter rér, 1656. Róma



Francesco Borromini:  
San Carlo alle Quattro  
Fontane, 1667. Róma





Mansart: Versailles-i palota, 1678.

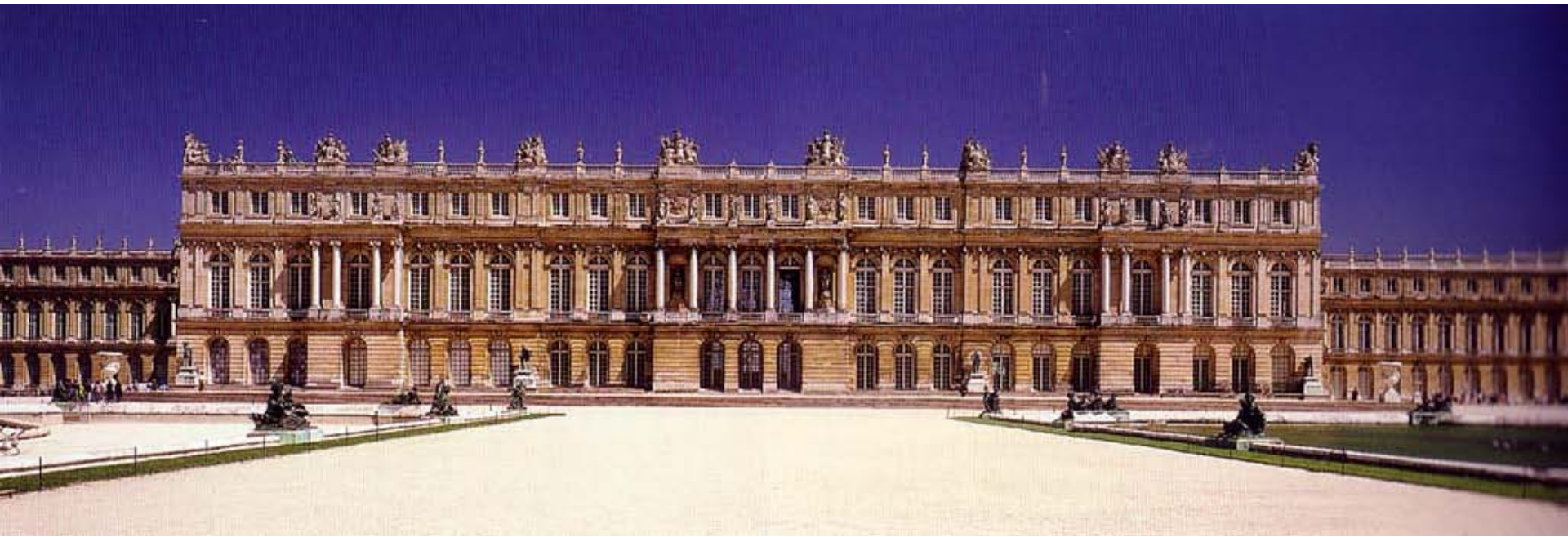



Melki bencés apátság, 1702.





Melki bencés apátság, 1702.



Drezdai Zwinger, 1711-1722.





Győri karmelita  
templom, 1721-1729.







Esterházy-kastély, XVIII.sz

Fertőd.





Santa Maria  
templom,  
XVIII.sz.  
Mexikó





Fellner Jakab:  
Líceum 1764.  
Eger



Gian Lorenzo  
Bernini:  
Dávid 1624.





Bernini: XIV. Lajos, 1665.  
Versailles, Chateau





## XIV. Lajos lovasszobra, Párizs, Louvre előtti tér





Bernini: Szent Teréz extázisa, márvány, 1647-1652. Róma, Santa Maria della Vittoria



Georg Raphael  
Donner:  
Szent Márton  
és koldus, 1735  
Pozsony,  
Szent Márton  
plébániatemplom  
főoltára





Caravaggio:  
Szent Máté és  
az angyal 1602.  
Róma, San  
Luigi dei  
Francesi



Caravaggio:  
Szent Pál  
megtéréése 1660  
Róma, S. Maria  
del Popolo

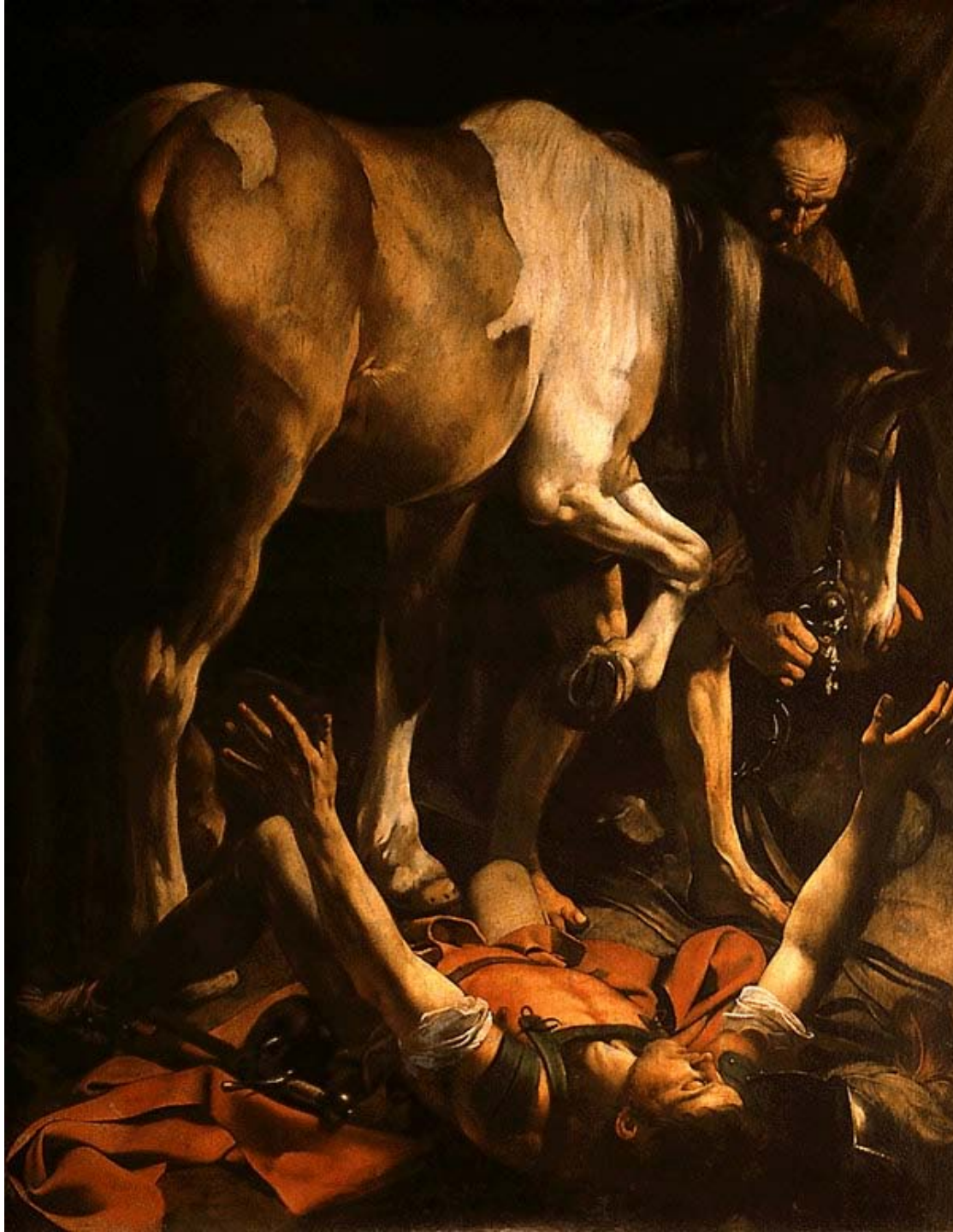





277 Caravaggio: Emmausi vacsora. 1601.

Caravaggio:  
Dávid Góliát  
fejével  
1609.  
Róma,  
Gallery  
Borghese





Peter Paul  
Rubens:  
A keresztt  
felállítása 1609.



Rubens:  
Leukkiposz  
Lányaink  
elrablása  
1618.  
München,  
Alte  
Pinakothek





Rubens:  
A részeg Silenus  
XVII.sz.





Rubens: Amazonok harca, 1618. München, Alte Pinakothek





Rembrandt: A lövészegylet kivonulása Éjjeli őrzárat, 1642.  
Amsterdam Rijksmuseum





Rembrandt: A három kereszt  
rézkarc 1662.





Rembrandt: Önarckép, 1665.  
Köln, Wallraf Richartz Museum

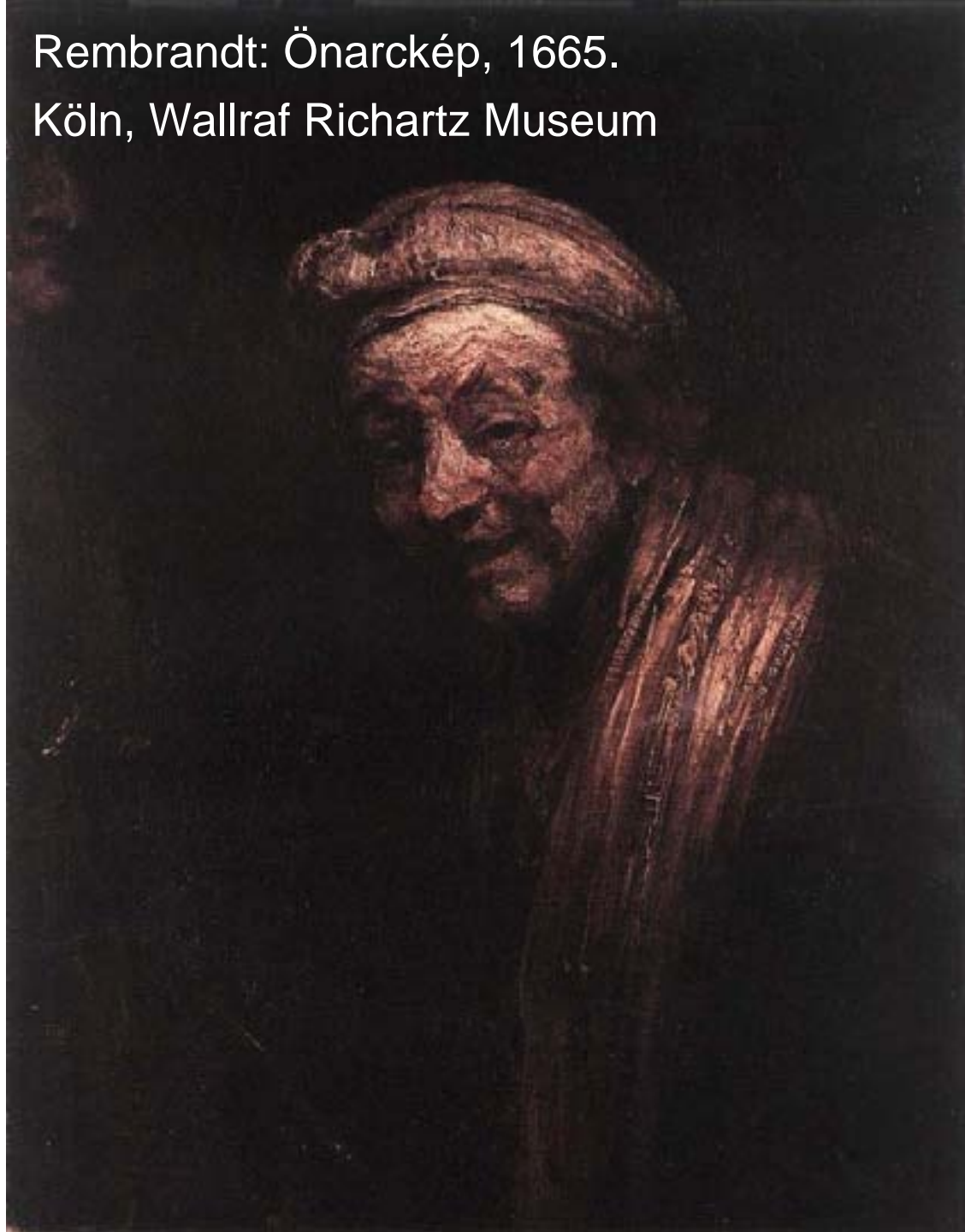

Velazquez: X. Ince Pápa portréja 1650.





Velazquez: Breda átadása, 1635-1636. Madrid, Prado.





Velazquez: Udvarhölgyek, 1656-1657.  
Madrid, Prado

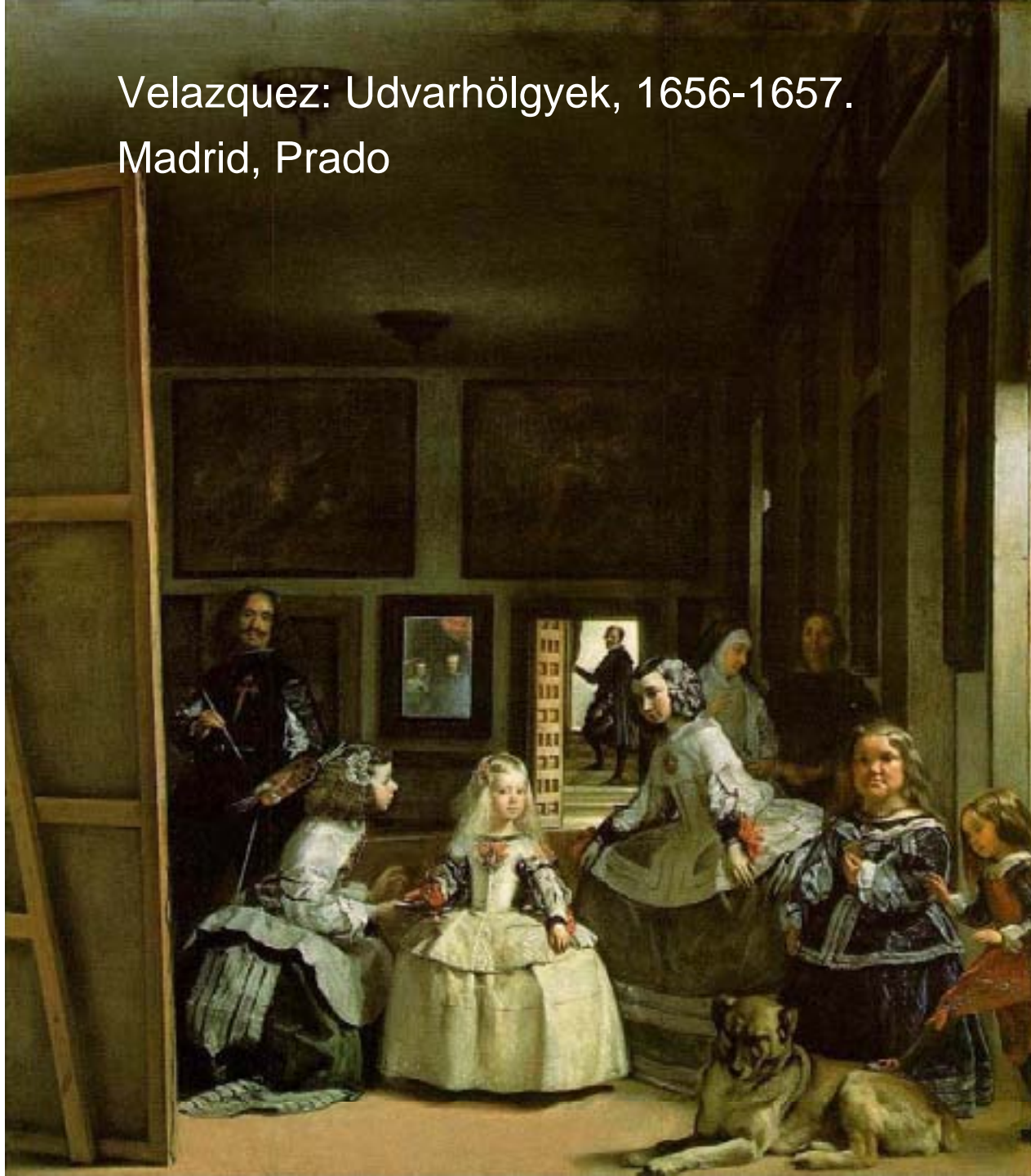



Jan Vermeer van Delft:  
Leány gyöngy fülbevalóval  
Turbános nő  
1665.



Vermeer van Delft: Festő és modellje  
1665-1670. Bécs, KM







Georges de La Tour: A születés XVII. sz. Rennes, Musee de Beaux Arts



André Pozzo: Szent Ignác megdicsőülése, 1691-1694. Róma,  
San Ignazio mennyezetfreskója







293 Andrea Pozzo: Allegory of Jesuits Missionary Work Italy 1691-94.



Mányoki  
Ádám:  
Rákóczi Ferenc  
1712.  
MNG





Giovanni  
Battista  
Tiepolo:



Tiepolo:  
Freskó  
a würtzburgi  
érseki palotából  
1753.





Franz Anton  
Maulbertsch:  
Jézus születése





Franz Sigrist: A négy fakultás, 1781. Eger, Líceum

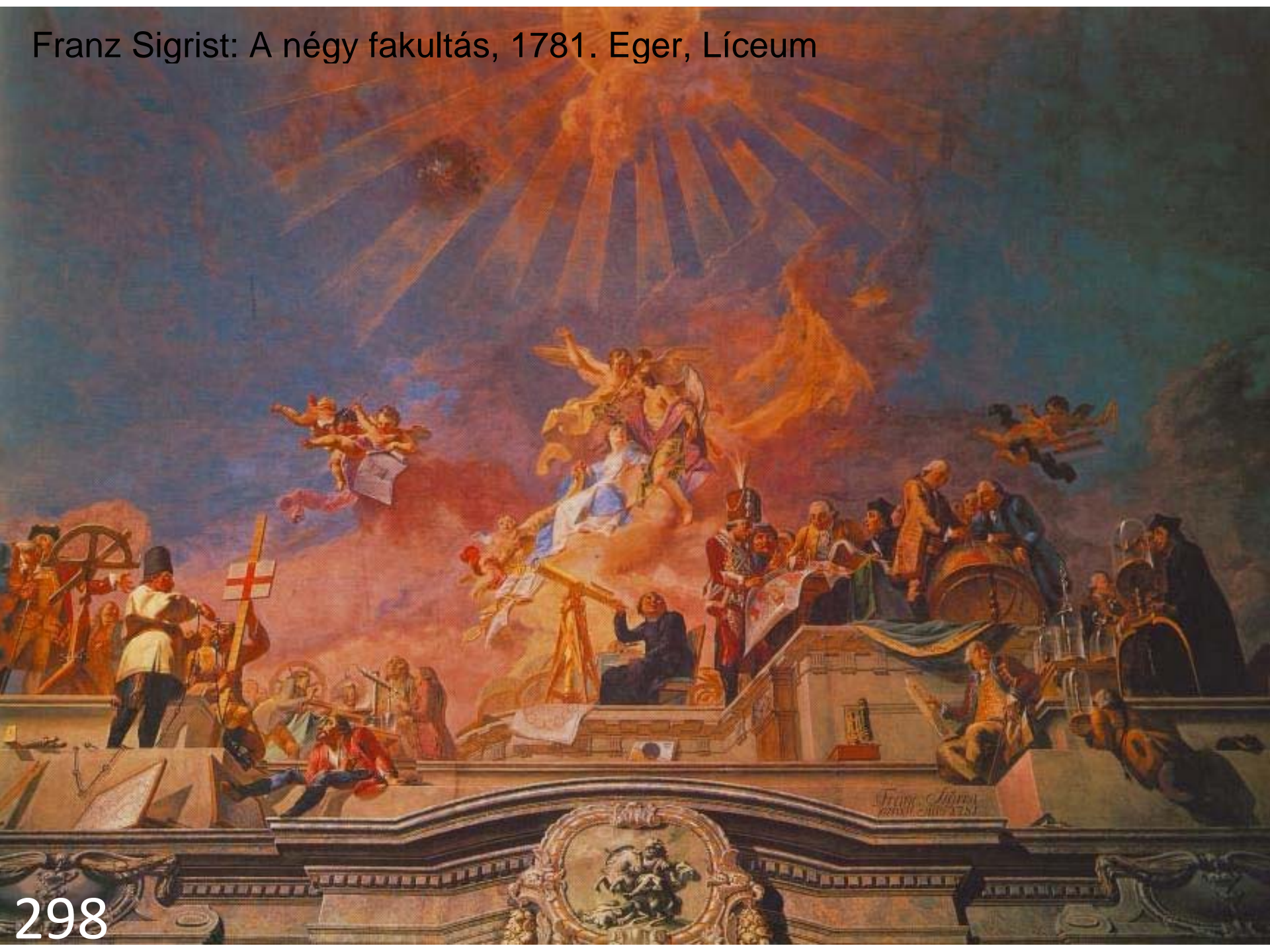



Chippendale  
bútorok  
1740-1780.  
szék fonadékos  
háttámlával



Chippendale  
bútorok  
1740-1780.  
könyves-  
szekrény





Jean-Antoine  
Watteau:  
Pierrot (Gilles)  
1721.  
Párizs, Louvre



Francois Boucher: Szőke odaliszk, 1752.





Jean Honoré Fragonard: A hinta, 1767.

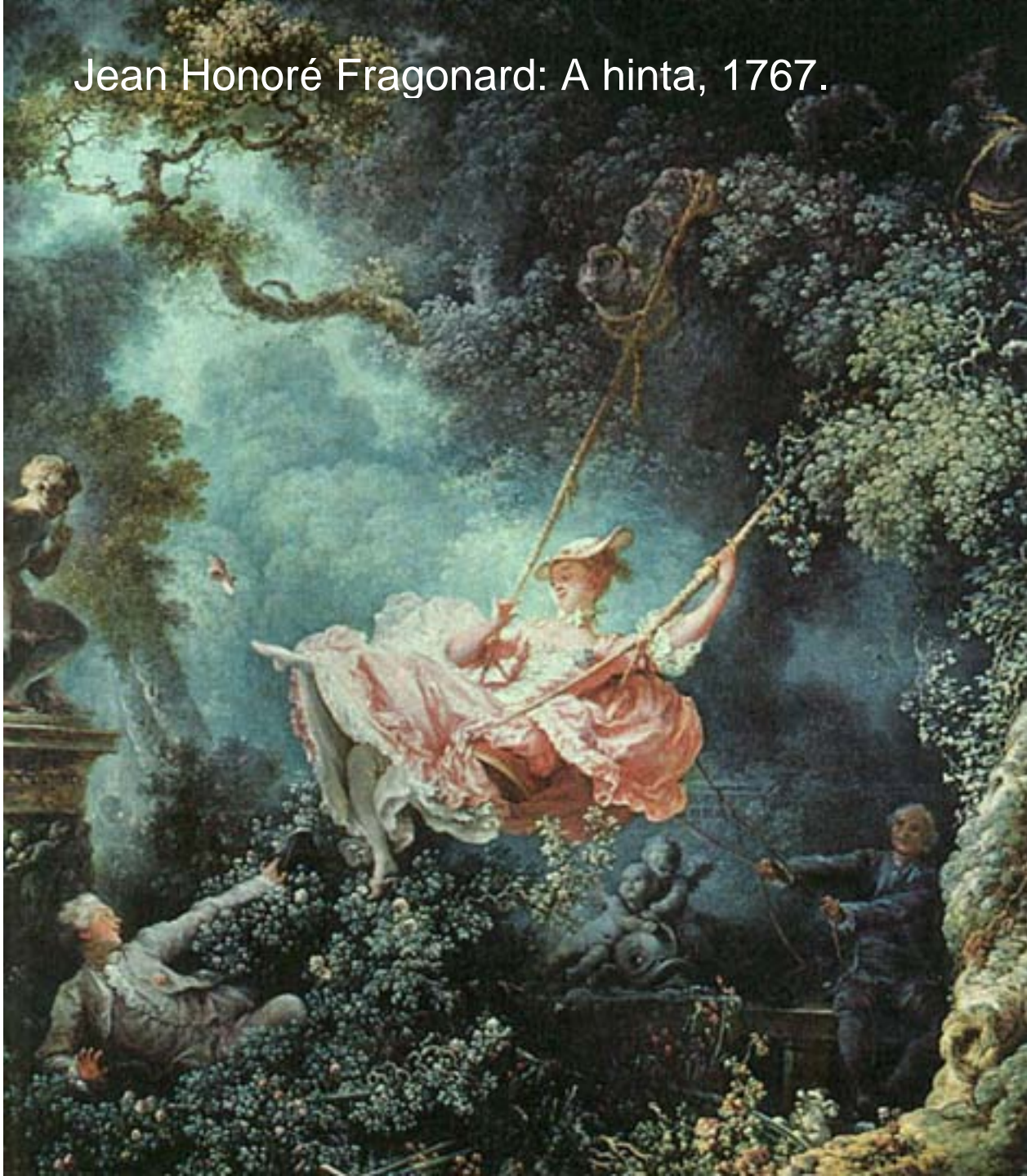



Chardin Jean Baptiste: A rája, 1726. Párizs, Louvre







Jean Baptiste Siméon Chardin: Önarckép

# KLASSZICIZMUS





307 British Museum 1823-1844. London

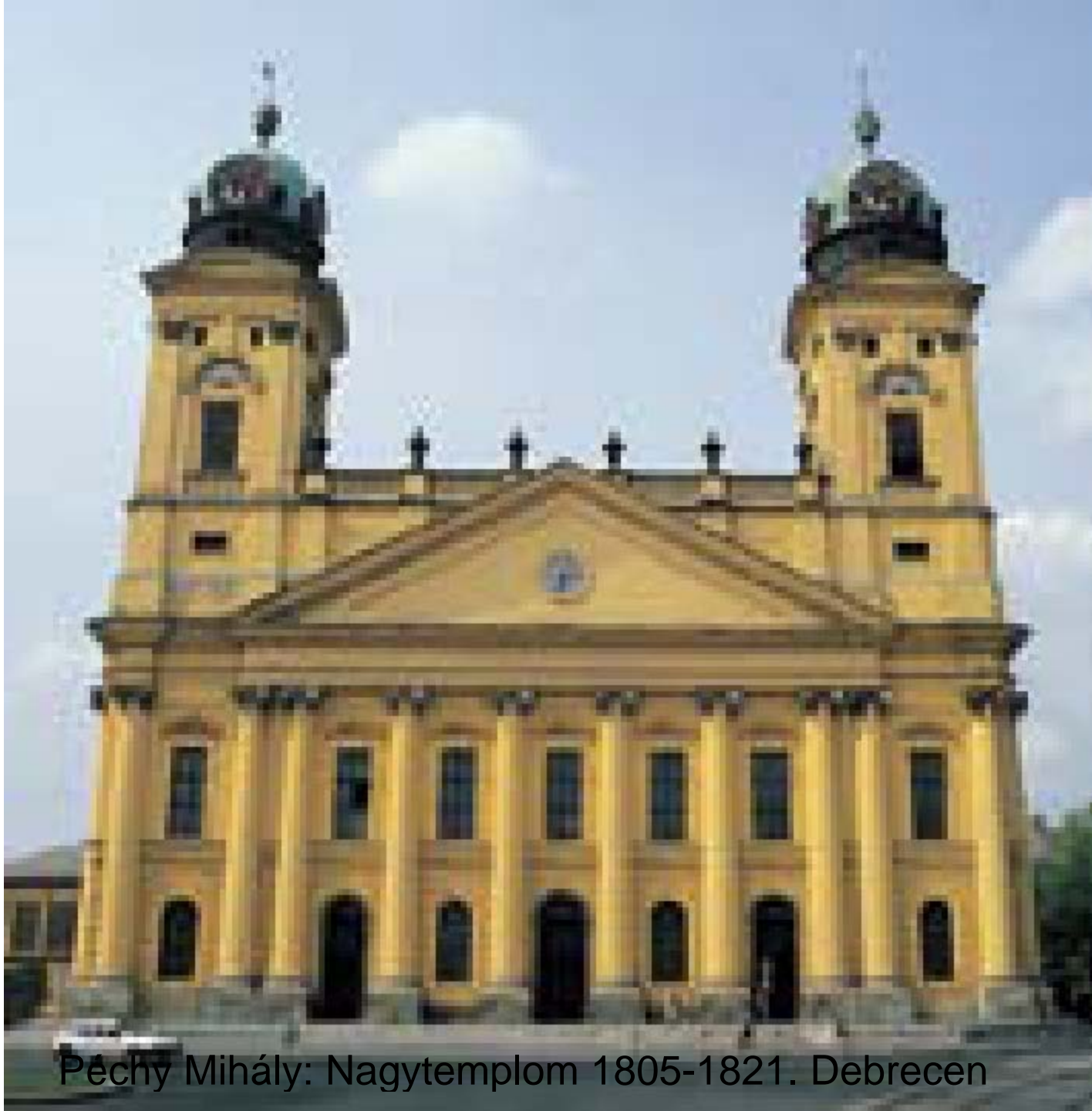



Pollack Mihály: Nemzeti Múzeum, 1837-1847. Budapest





Hild József: Főszékesegyház, 1839-1856.  
Esztergom







Canova:  
Ámor és  
Psyché  
1800.  
márvány  
Párizs,  
Louvre





Canova:  
Hercules és  
Lichas 1795-  
1815.  
Róma,  
Galerie Nationale  
d'art Moderne



Ferenczy István:  
A szépmesterségek  
kezdetei,  
Pásztorlányka  
1820-1822  
MNG







315

Nicolas Poussin tájkép XVII.sz.

Jacques Louis David: A Horatiusok esküje, 1784. Párizs, Louvre





Jacques-Louis David: Marat halála, 1793.  
Musées Royaux des Beaux-Arts, Belgium





Jacques Louis David: Bonaparte a Szent Bernát  
hágón 1800.  
Musee National  
de Malmaison,  
France





Jean Auguste Dominique Ingres:  
A nagy fürdőző 1808. Párizs, Louvre







321

Ingres: Törökfürdő, 1862., Párizs, Louvre

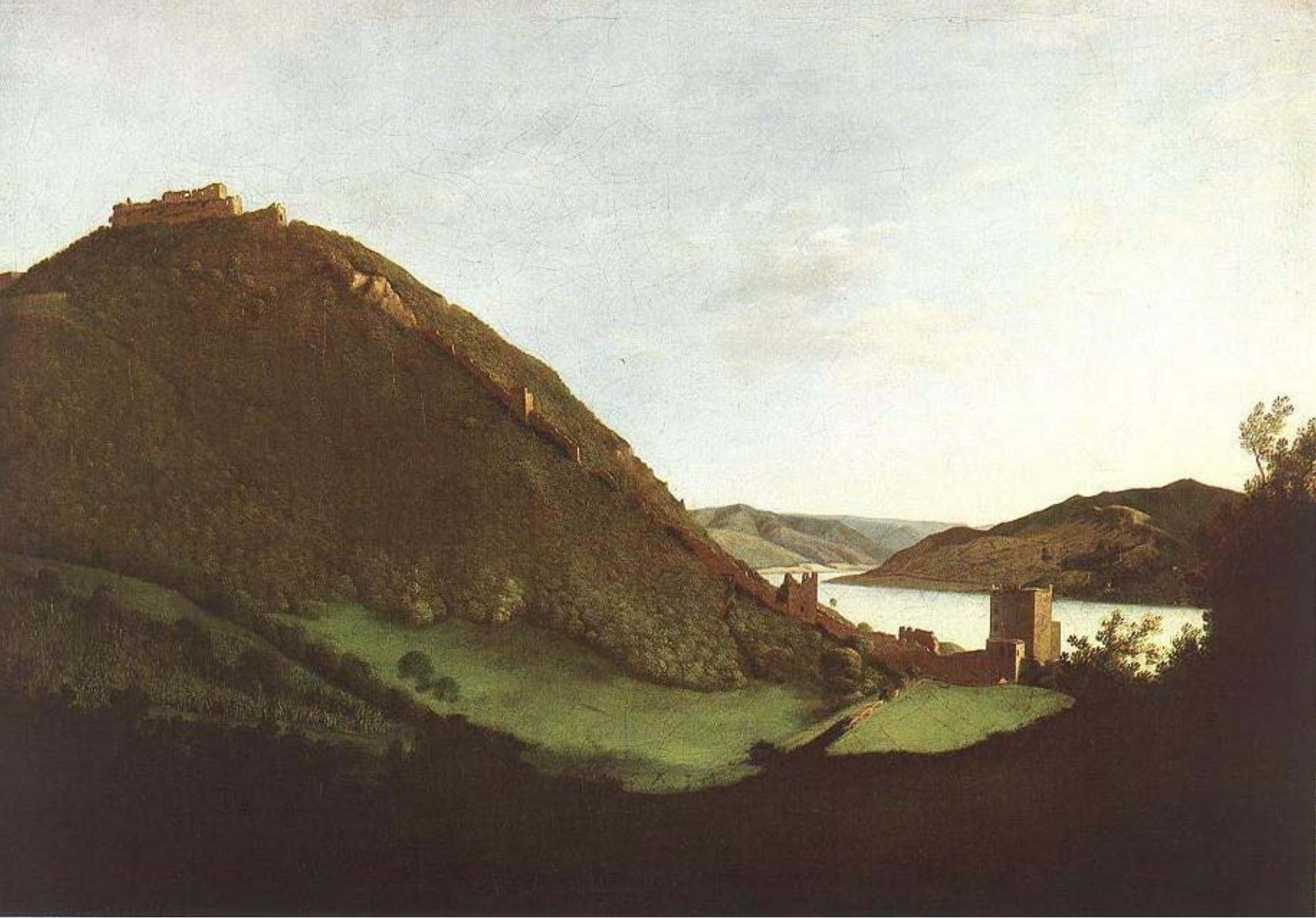

322 Id. Markó Károly: Visegrád, 1828. MNG



Egy Wedgwood  
kerámia

19.sz

pl.váza

1805.

London

Victoria and

Albert Museum

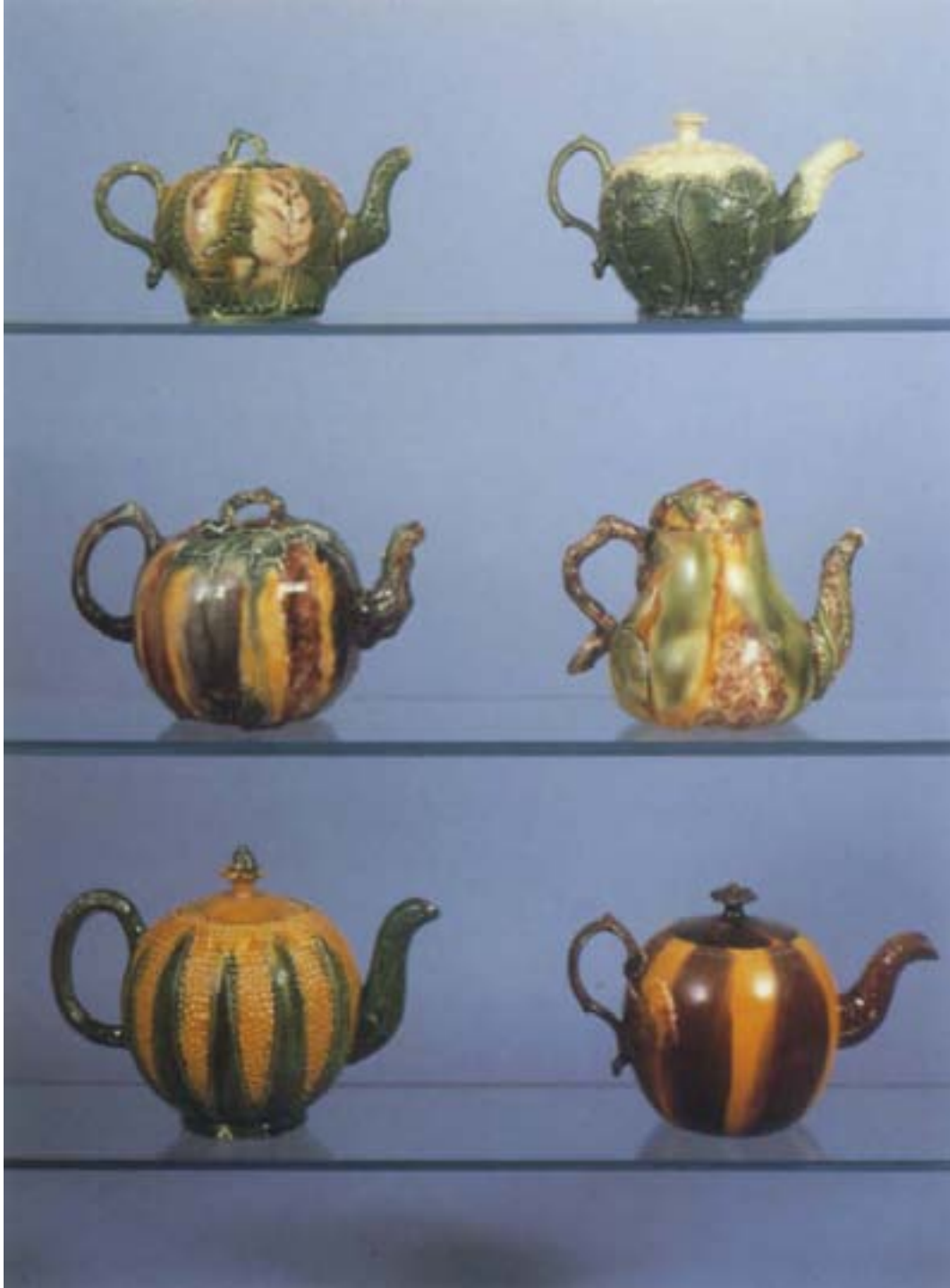

323

Copf stílusú  
bútorok  
1790.  
felnyitható öltöző  
asztal  
Ipar, Budapest





Napóleon  
trónja, Párizs,  
Louvre



# ROMANTIKA, REALIZMUS





327 Londoni Parlament, 1840-1865.

Kristálypalota  
1851.  
London  
Világkiállítás  
fotó





Párizsi Operaház 1860-1875.



Eiffel torony  
1889.







331 Feszli Frigyes: Vigadó, 1859-1865., Budapest









333 Steindl Imre: Országház, 1885-1894., Budapest



A budavári Nagyboldogasszony plébániatemplom, 1874-1896. restaurálta Schulek Frigyes, XIII-XV. századi épületet Mátyás templom





Francois Rude:  
Marseillaise,  
1836. Párizs







336 Rude Marseillaise: Diadalív 1836. Párizs



Izsó Miklós:  
Táncoló paraszt  
1870.  
MNG



337

Goya: 1808.Május.3., 1814. Madrid, Prado





Francisco Goya:  
Ha alszik az ész  
szörnyek születnek,  
rézkarc és tinta,  
1797.

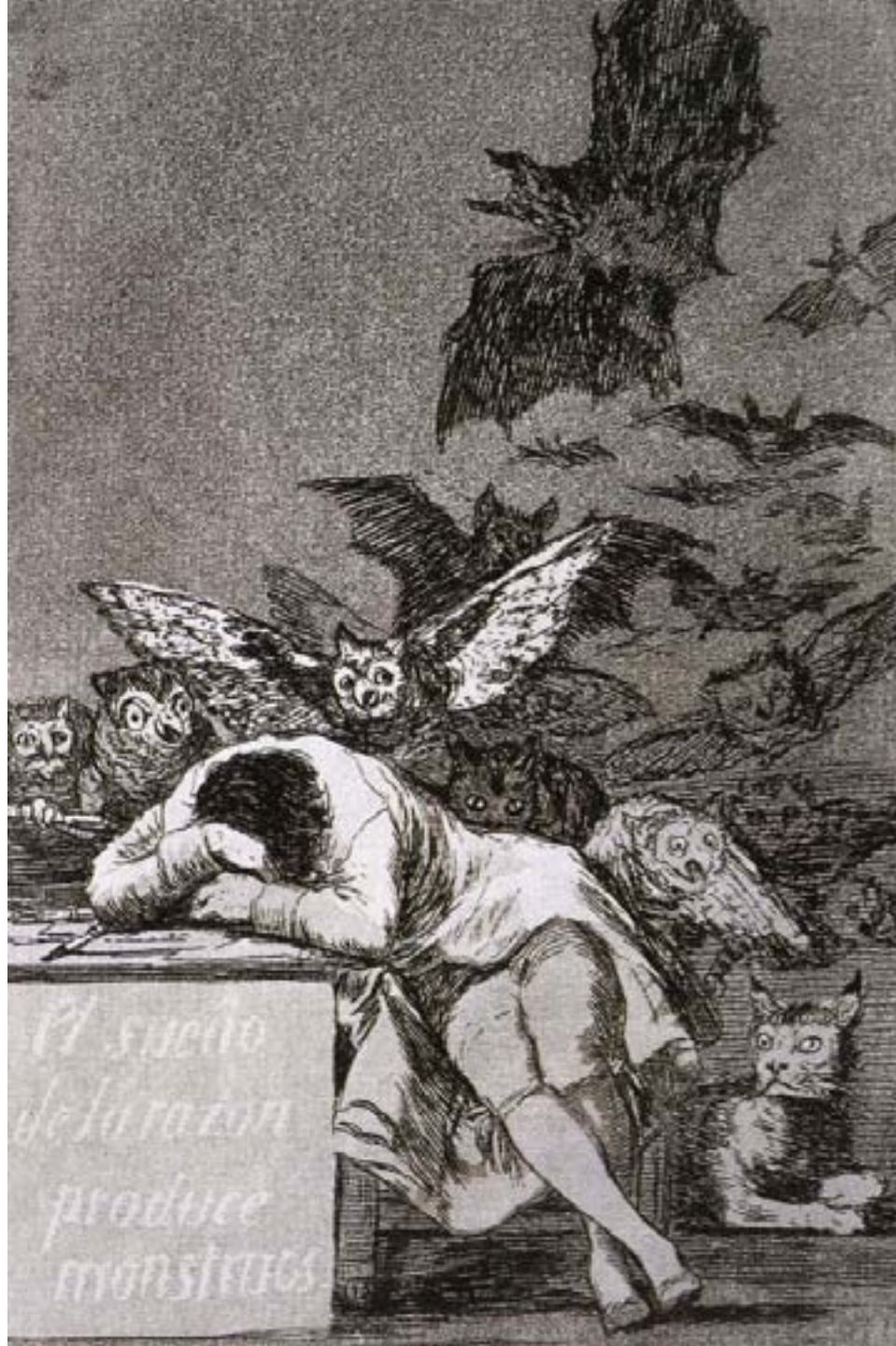

Goya:  
Saturnus felfalja  
gyermekét 1824.





Caspar David Friedrich: Vándor a ködtenger felett, 1818.  
Hamburg, Kunsthalle





342 C.D.Friedrich: A Jeges-tenger Az Esploratore elsüllyedése 1823.





343 Theodore Géricault: A Medúza tutaj, 1818-1819. Párizs, Louvre



Eugène Delacroix: A khioszi mészárlás, 1824.





Delacroix:

A szabadság vezeti a népet

1830.

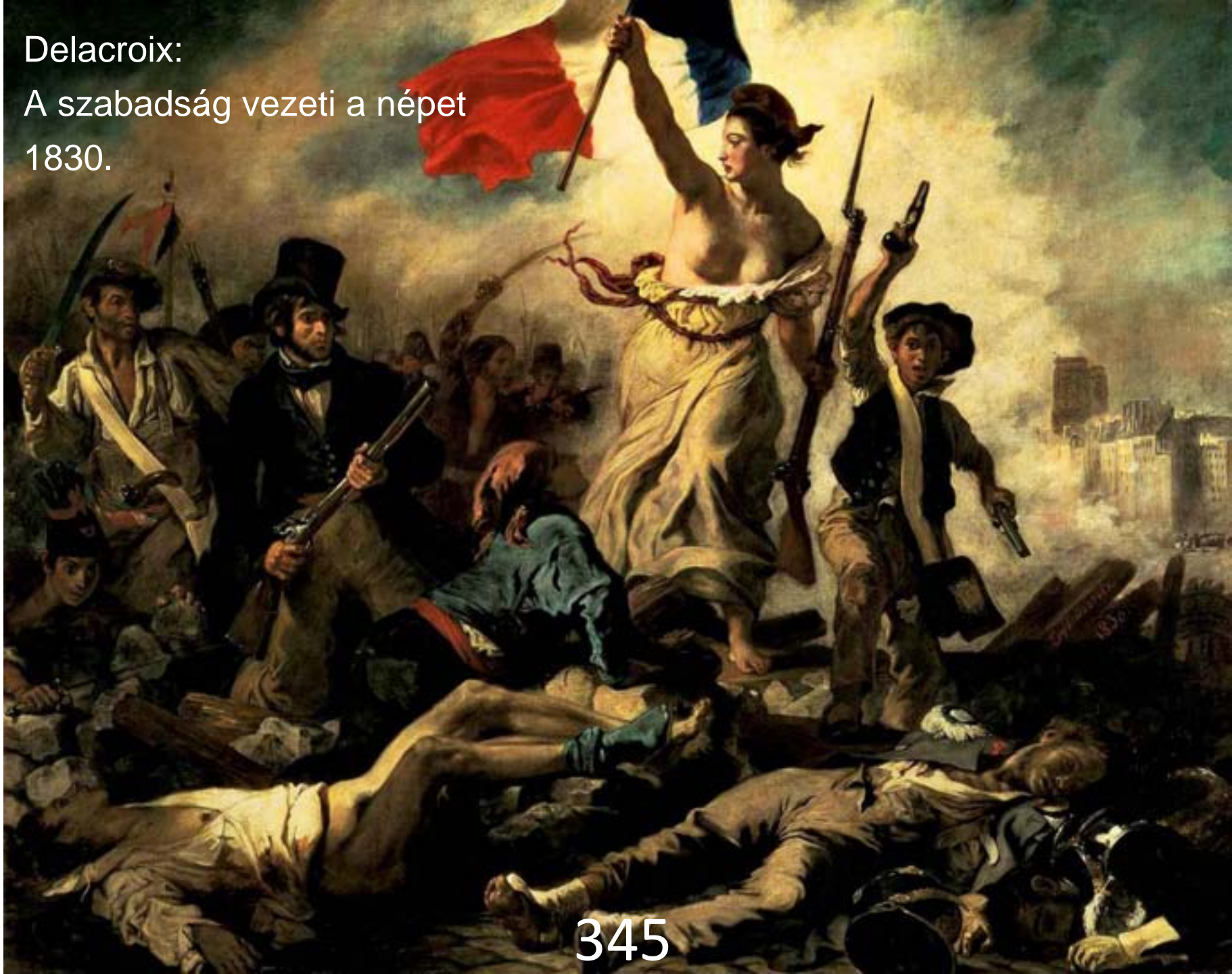

Blake:  
A teremtő,  
1826.  
Manchester,  
Whiteworth  
Gallery







347 Turner: Gőzhajó hóviharban, 1842, London, Tate





348 Turner: Eső, gőz, sebesség, 1844. London, National Gallery



Pavel Fedotov: Az őrnagy leánykérőben 1848. Moszkva, Állami Tretyjakov Galéria



Montpellier, Musee Fabre







351 Courbet: Ornans-i temetés, 1850.

Courbet:  
Füüdőzők  
1819-1877

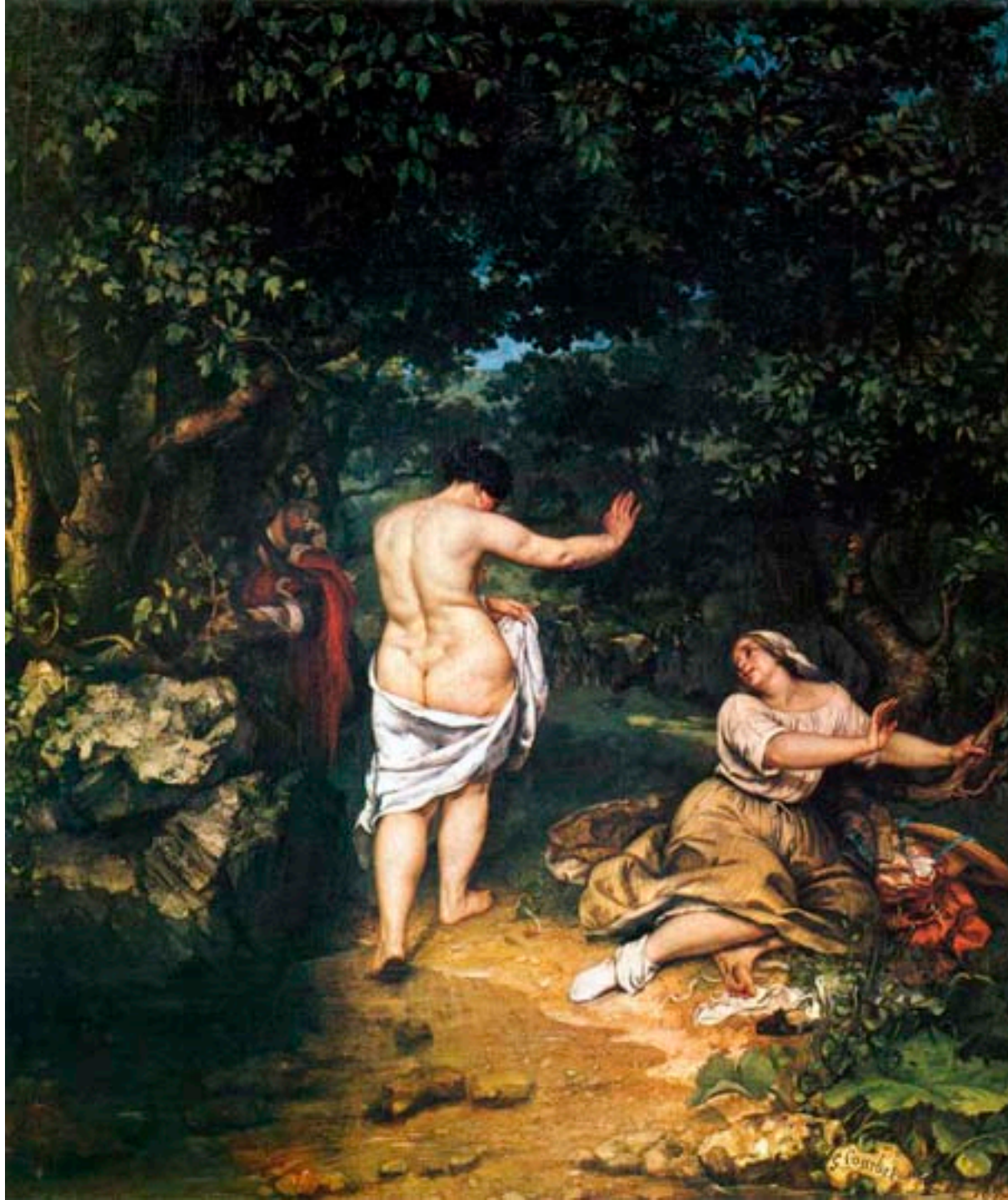



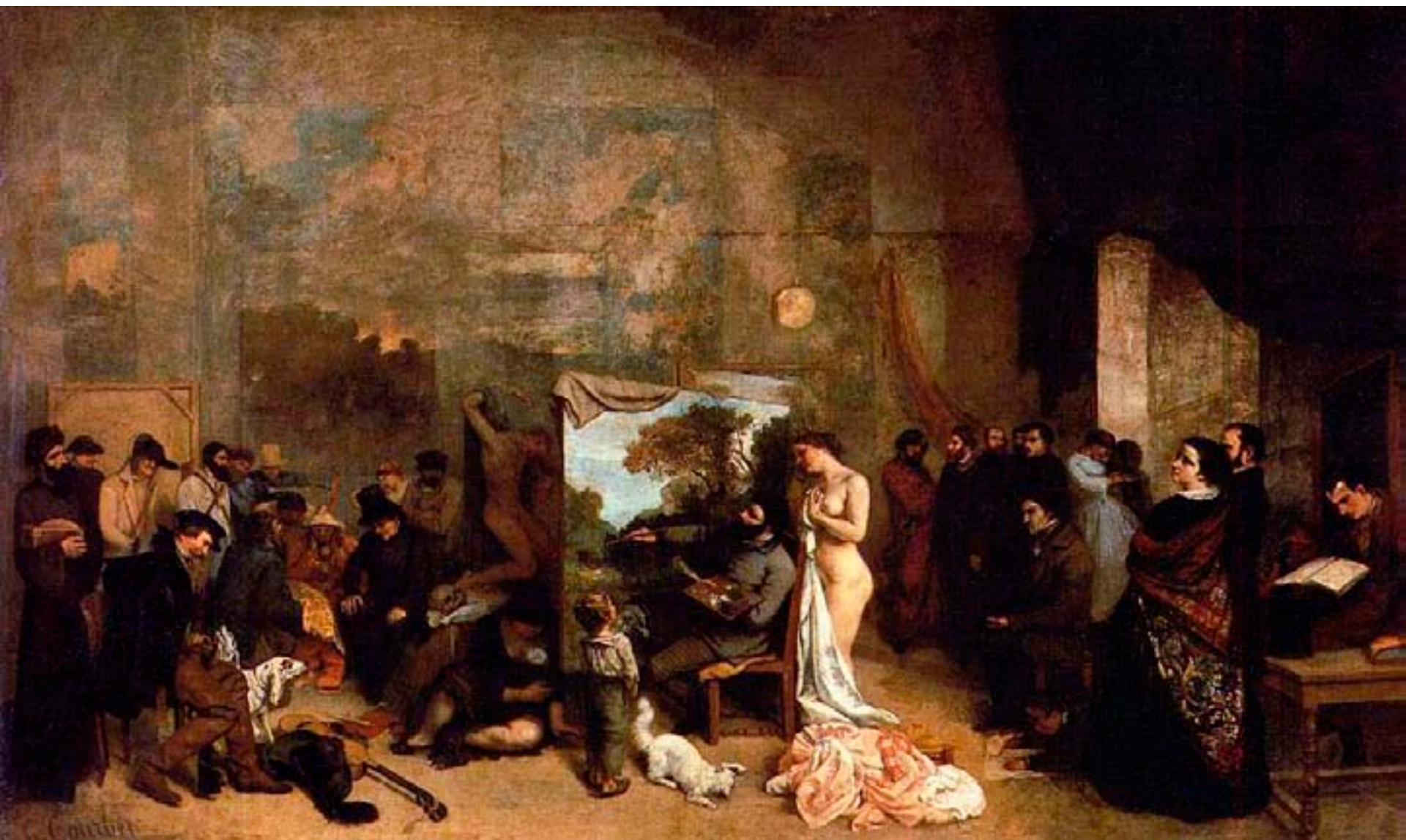

353

Courbet: A festő műterme, 1855.



Jean Francois Millet: Kalászszedők, 1857, Párizs





Daumier:  
Mosónó,  
1860-61,  
Párizs,  
Musée d'Orsay





356 Ilya Repin: Hajóvontatók a Volgán, 1870-73.



Borsos József:  
Nemzetőr  
1848.  
Történelmi  
Képcsarnok,  
MNM





358 Madarász Viktor: Hunyadi László siratása, 1859. MNG



Székely Bertalan:  
Egri nők, 1867.  
MNG





360 Munkácsy Mihály: Tépéscsinálók, 1871. MNG





Barabás Miklós:  
Bittó Istvánné  
1876.  
MNG





Paál László:  
Út a fontainebleau-i  
erdőben, 1876.  
MNG



Zichy Mihály  
illusztrációja  
Arany balladájához  
Híd-avatás címmel  
1877.  
MNG







365 Benczúr Gyula: Budavár visszavétele, 1896. MNG

Lotz Károly:  
Operaház  
kupolájának  
freskója,  
A zene  
apoteózis  
1883-1884





# IMPRESSZIONIZMUS, POSZTIMPRESSZIONIZMUS

Manet: Reggeli a szabadban, 1863, Párizs Louvre







369 Manet: Olympia, 1863., Musée d'Orsay, Párizs





370 Manet: Folies Bergere 1882.



Manet: Claude Monet csónakműtermében fest (A bárka) 1874,  
München, Neue Pinakothek



Edgar Degas:  
A tánc csillaga  
1878.  
Musée d'Orsay  
Párizs





Edgar Degas:  
Kis 14 éves táncoslány  
1881. Musée d'Orsay  
Párizs



Claude Monet: A felkelő nap impressziója, 1872. Párizs, Musée Marmottan





Monet:  
Roueni katedrális  
1892-1894  
kapuzat napfényben  
New York  
Metropolitan M.

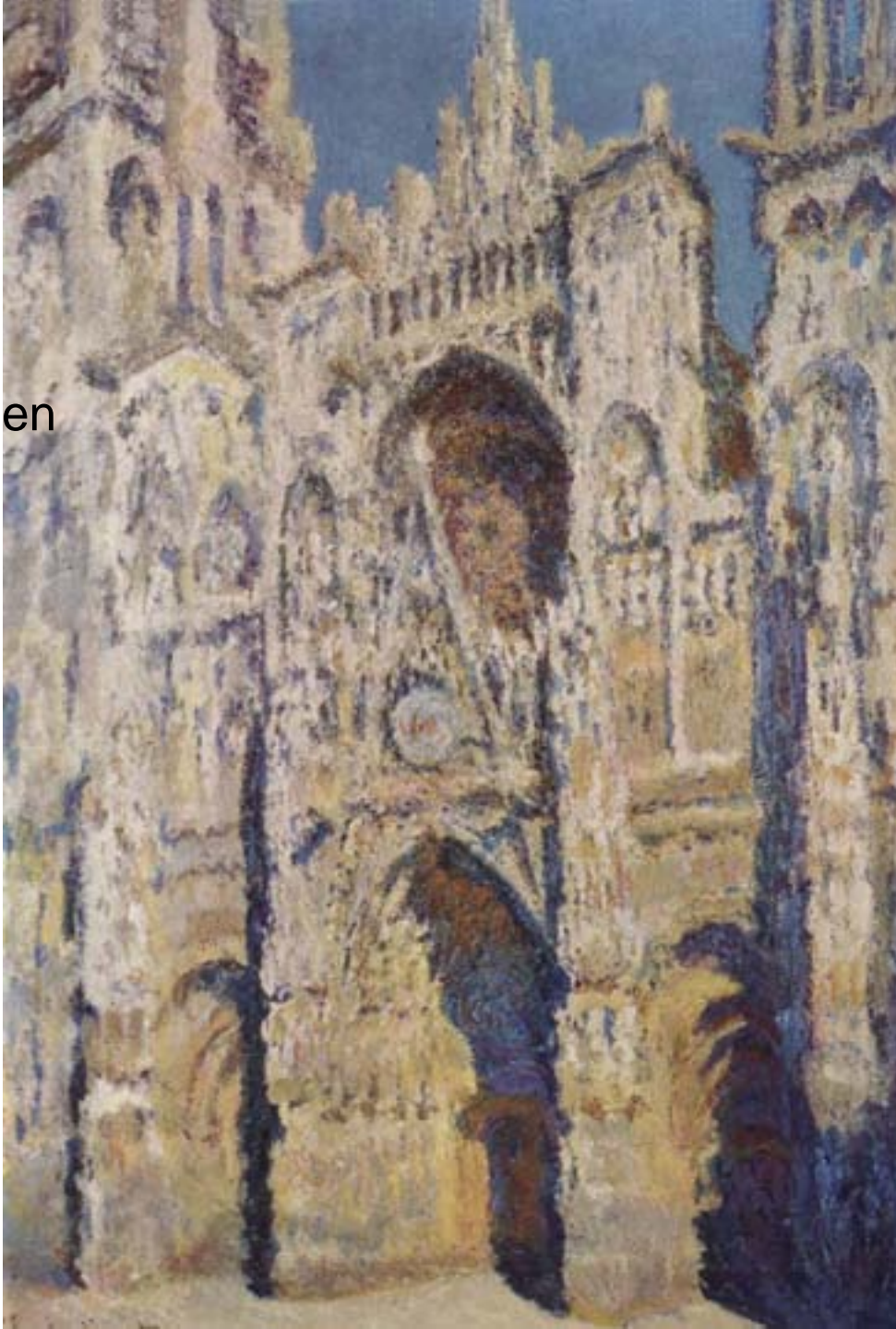



Monet: A Londoni Parlament - a ködön áttörő nap, 1904.  
Musée d'Orsay, Párizs





Renoir: A Moulin de la Galette, 1876. New York, J H Whitney Gyűjt.

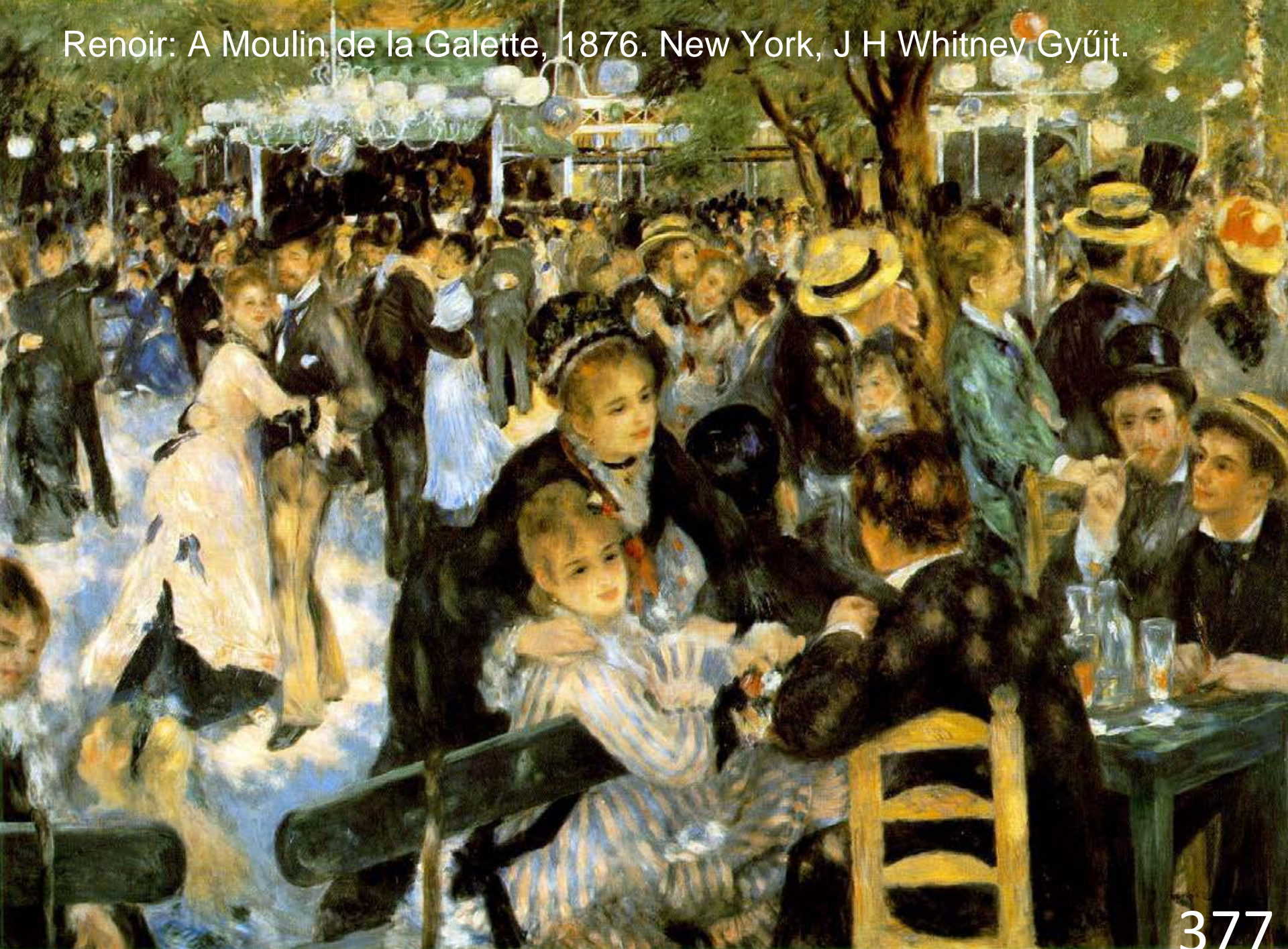





378 Renoir: A nagy fürdőzők, 1887. Németország, Museum of Art



Degas:  
Balettiskola  
1874.  
Musée d'Orsay  
Párizs







Georges Seurat: Vasárnap délután, 1884-1886.





Paul Cezanne: Mont Sainte Victoire Bellevue felől nézve, 1885-1887.  
London, Courtauld Institute





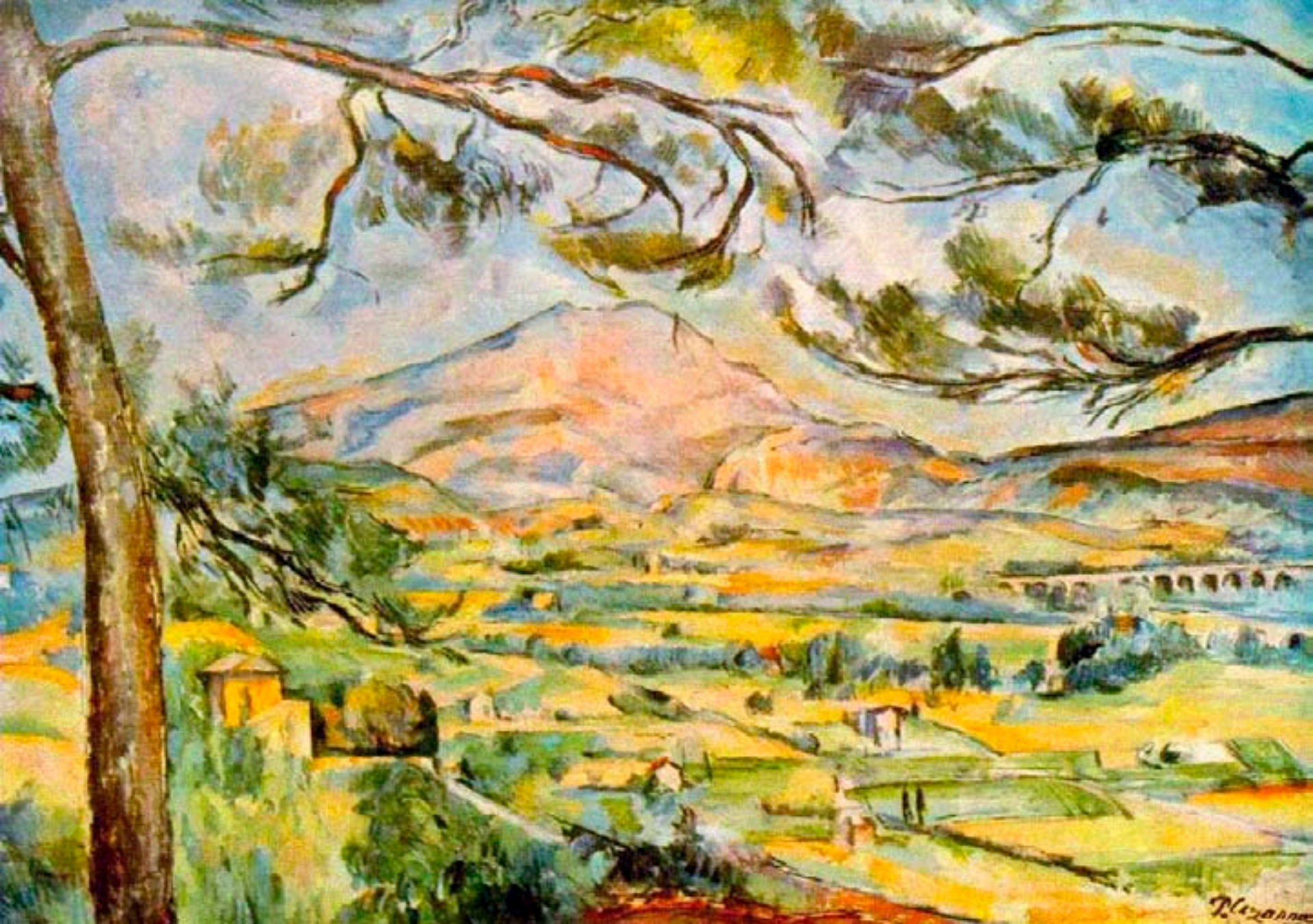

383 Cézanne: Mont-Sainte-Victoire, 1885-87.



Cezanne: Nagy fürdőzők (Fürdőző nők) 1898-1905., Philadelphia Museum of Art

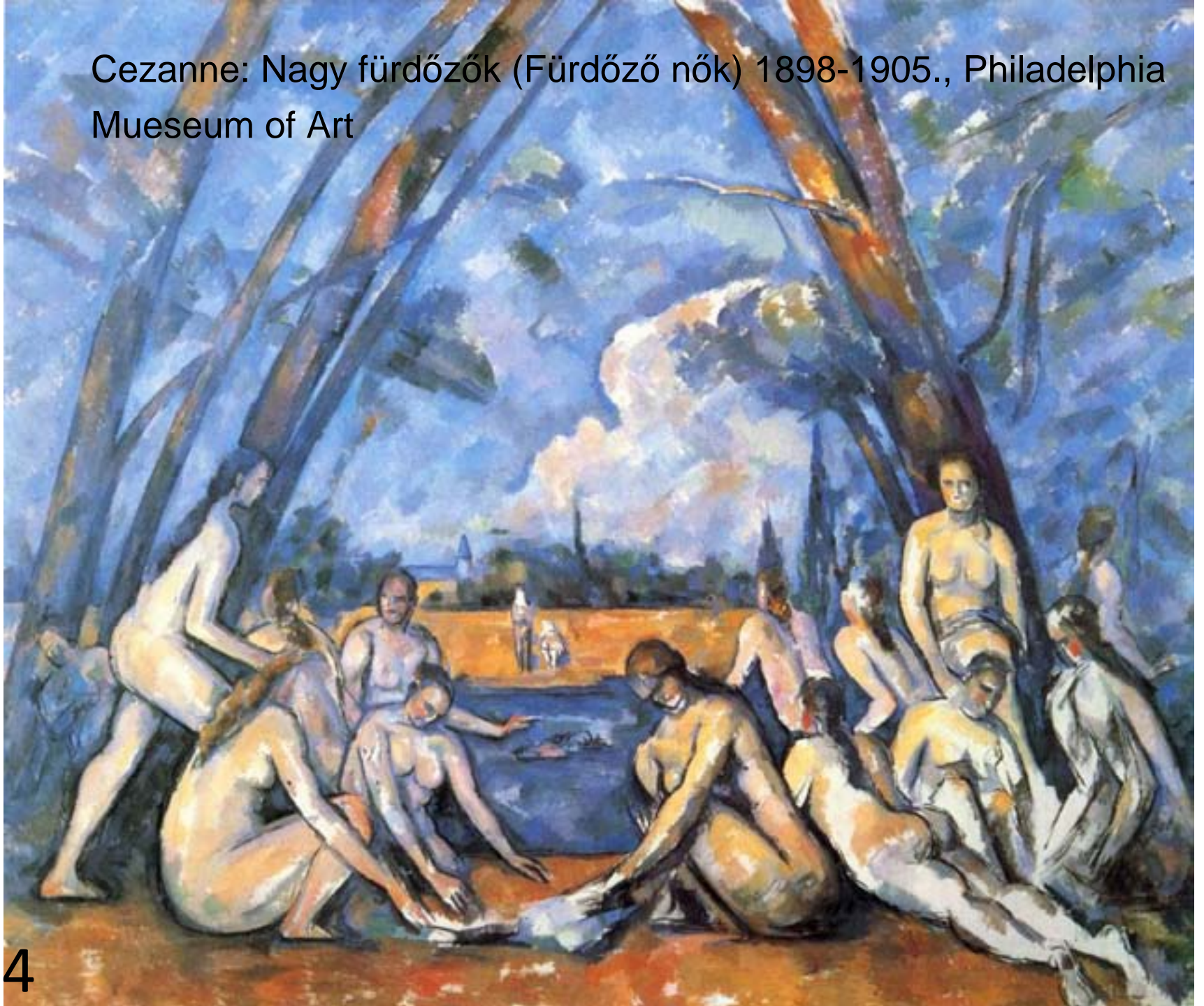



Cezanne: Edények kosár gyümölcsök 1888-90





Cezanne: Csendélet korsóval és gyümölcsökkel 1887-1895  
Oslo, Nationalgalerie





Van Gogh:  
Önarckép.  
1890.  
Párizs,  
Jeu de Paume

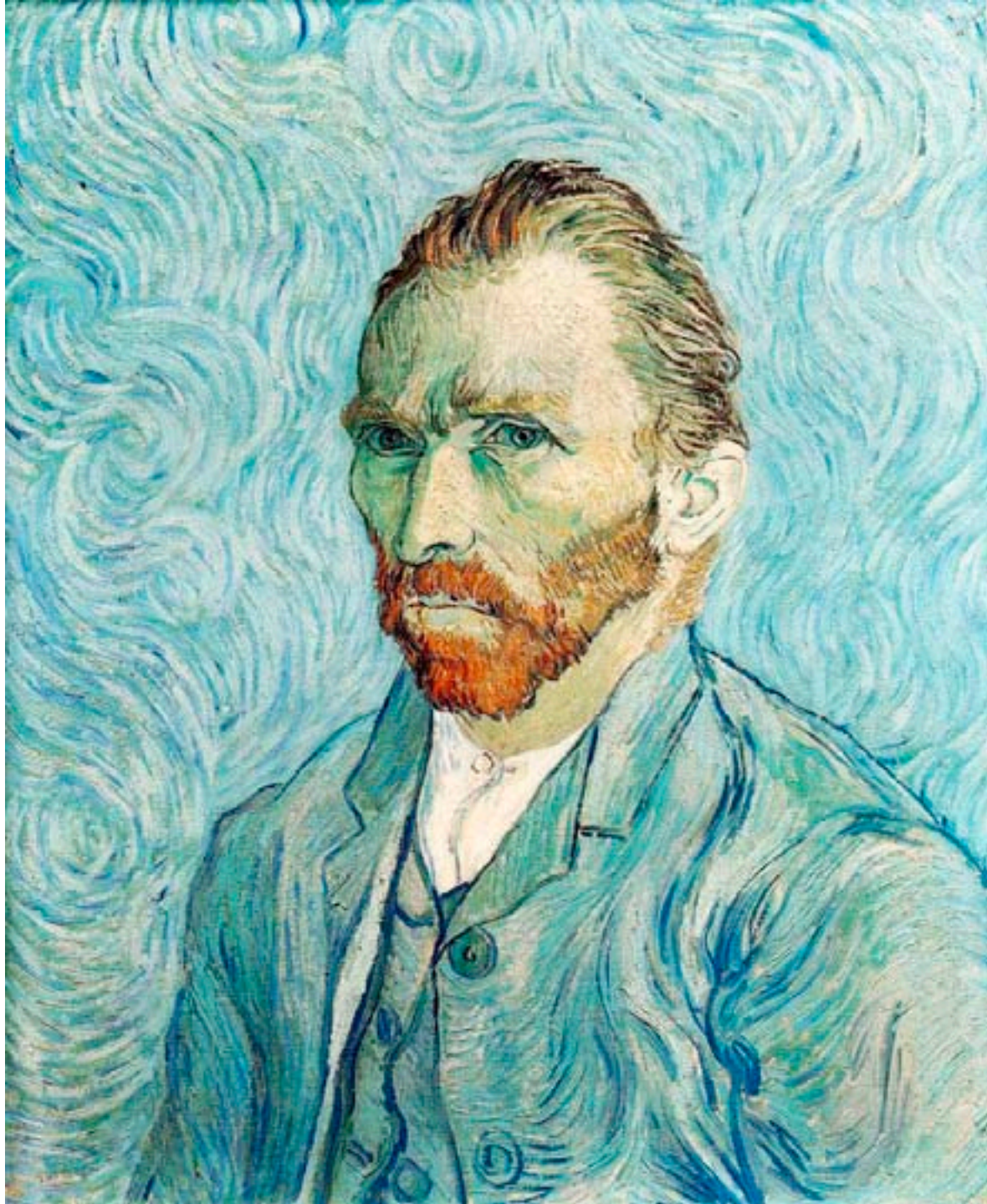

Van Gogh:  
Napraforgók,  
1888.

Váza 15 napraforgóval  
London,  
National Gallery







Van Gogh szobája Arlesben  
1888. első változat  
Amszterdam, Van Gogh Múzeum



Van Gogh:  
Falusi út  
Provenceban  
éjjel 1890.

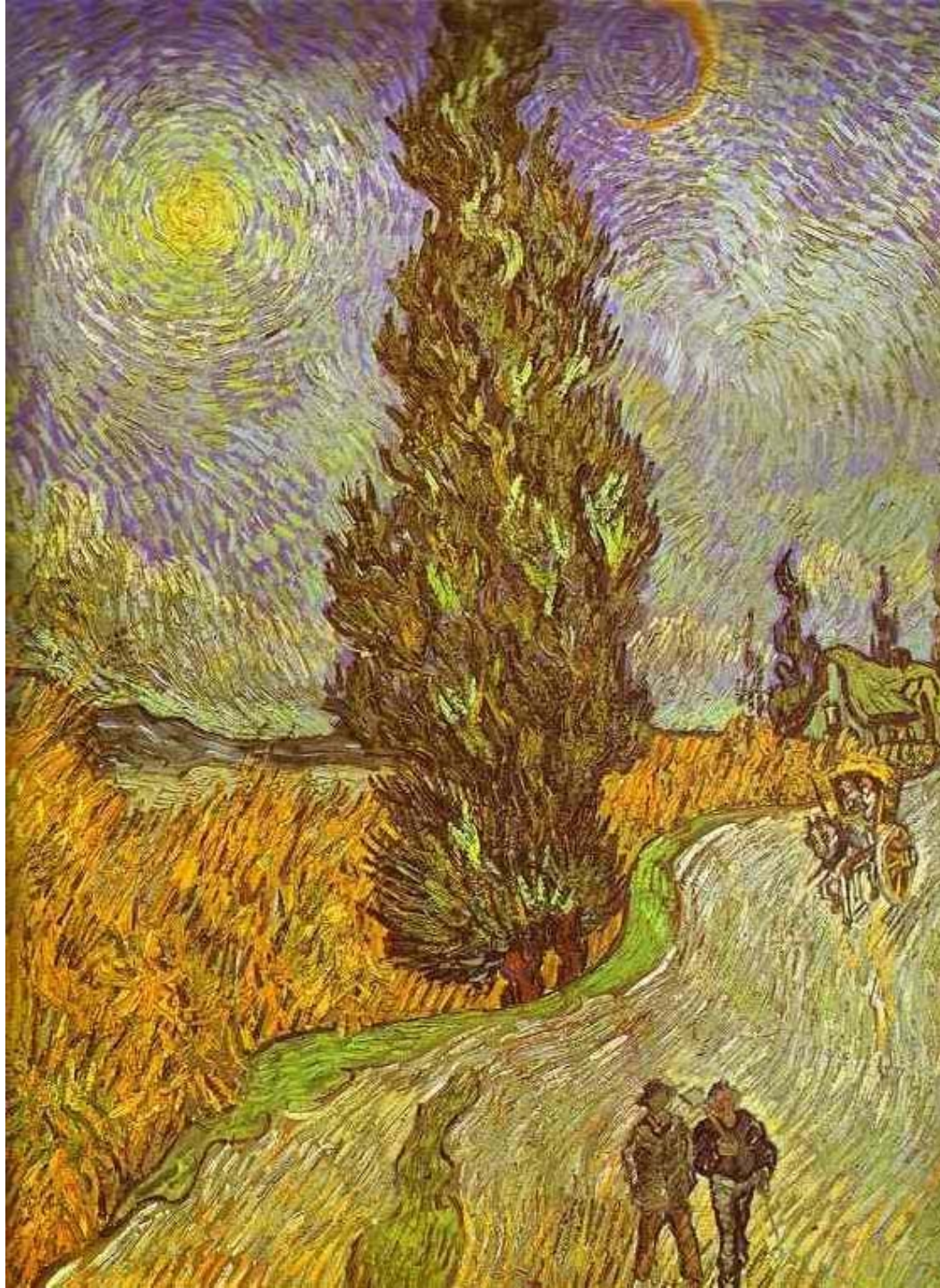





391 Paul Gauguin: Mi újság? Tahiti nők 1892. Drezda



Gauguin: Látomás ige hirdetés után vagy Jákob harca az angyallal  
Edinburgh, 1888. National Gallery of Scotland

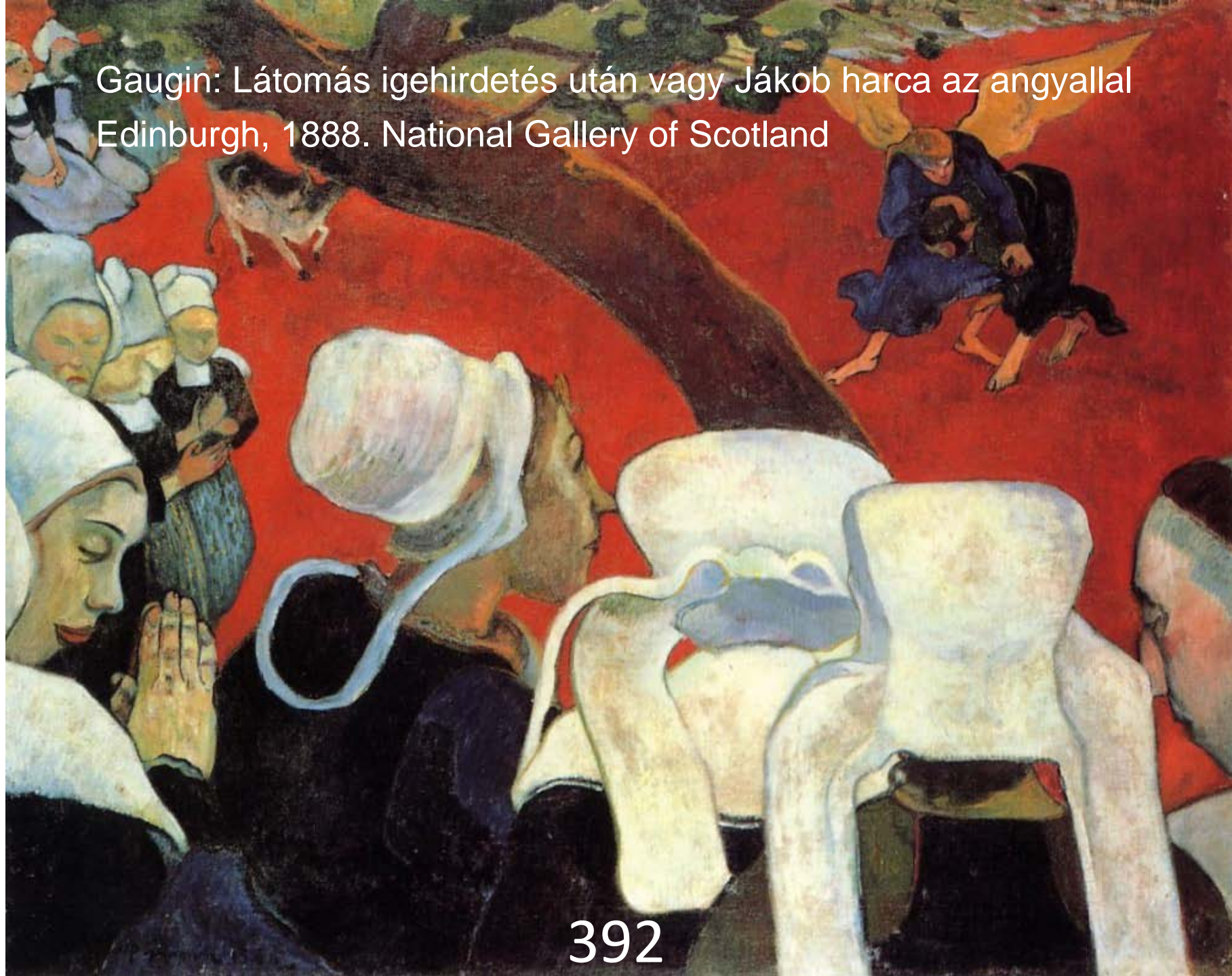



Gauguin: Honnan jövünk? Kik vagyunk? Hová megyünk? 1897.  
Boston, Museum of Fine Arts



# EKLEKTIKA, SZECCESSZIÓ, SZIMBOLIZMUS





395 William Morris Philip Webb: Vörös ház 1859. London

Gaudi:  
Sagrada Familia  
1884,  
Barcelona





Gaudi: Casa Mila, 1906-1912. Barcelona





# Gaudi: Parc Guell, 1900-1914, Barcelona





Victoria Horta:  
Tassel ház  
1892-1893  
Brüsszel

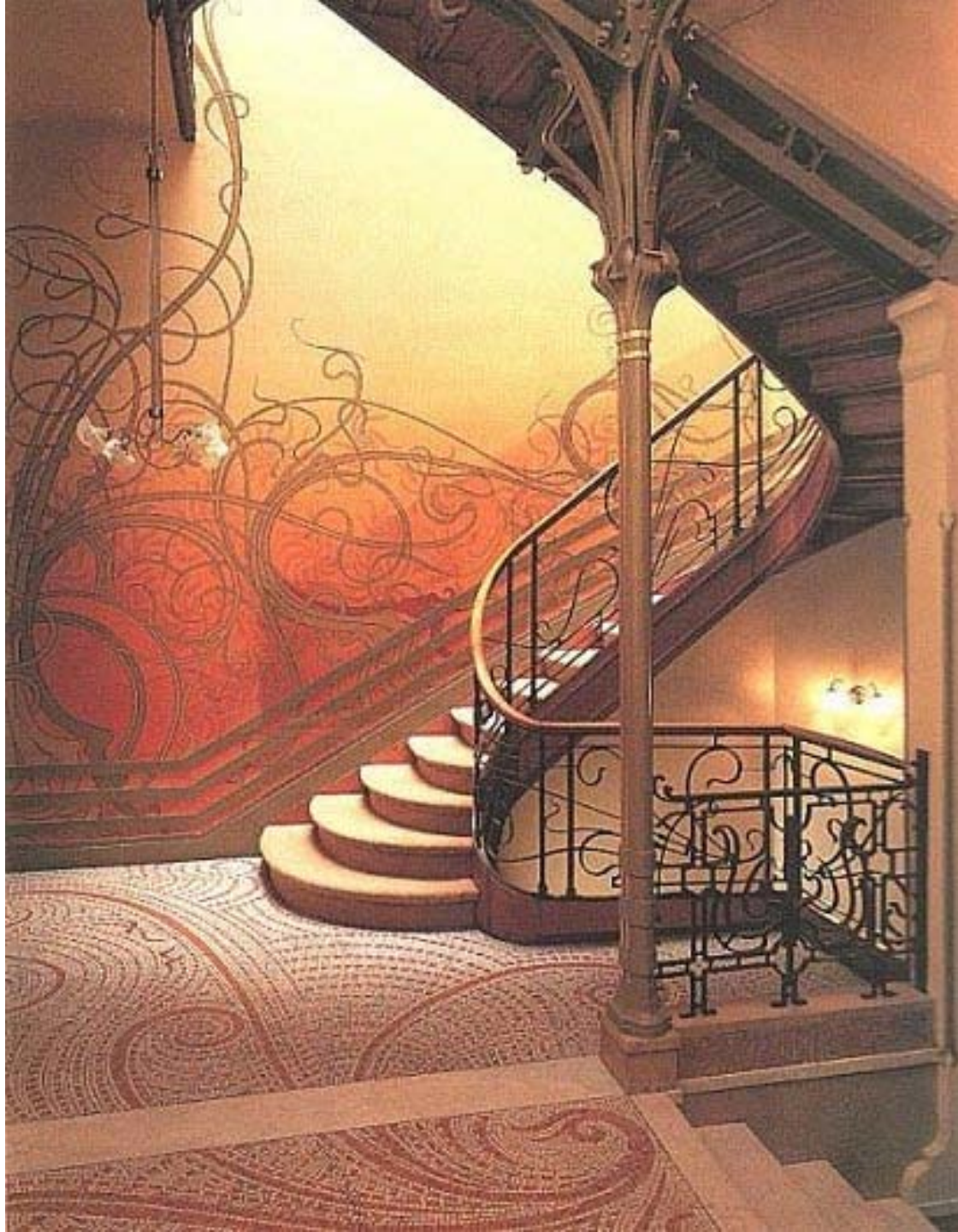

Charles Rennie Mackintosh:  
Glasgow-i Művészeti Iskola,  
1898 k.

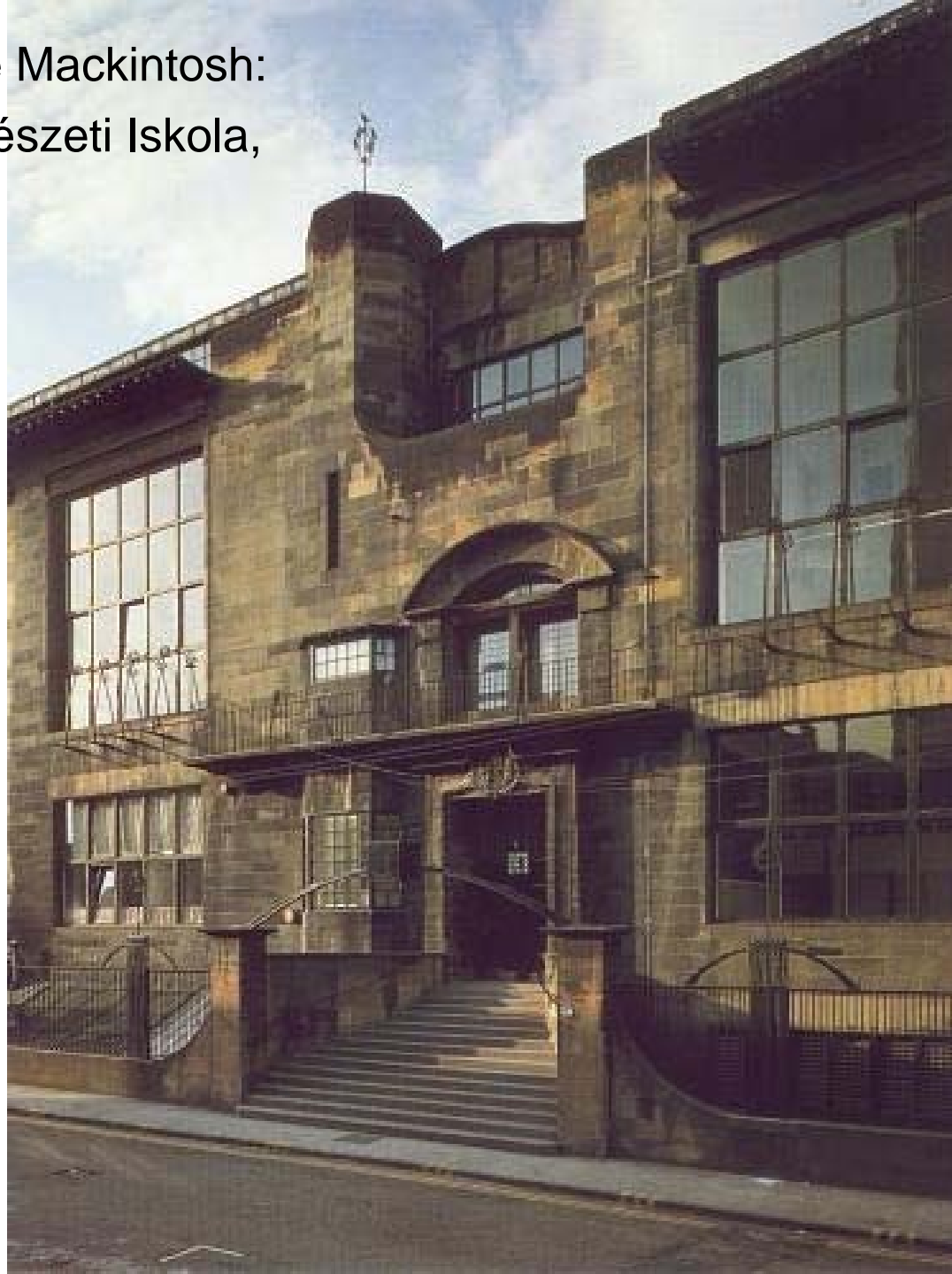



Joseph-Maria) Olbrich: A bécsi szecesszió épülete, 1898-1899. Bécs





402

Olbrich: A bécsi szecesszió épülete, 1898-1899. Bécs



Lechner Ödön: Postatakarékpénztár,  
1899-1902. Budapest



Schickedanz Albert: Szépművészeti Múzeum, 1899-1906. Budapest





Kós Károly-  
Zrumecky Dezső:  
Madárház,  
1908-1909.  
Budapesti Állatkert



Medgyaszay István:  
Rákosmulyadi r. k.  
templom, 1910.





Auguste) Rodin  
A csók,  
1894.  
Párizs,  
Rodin Múzeum



Fadrusz János: Mátyás király emlékmű, 1895-1902. Kolozsvár





Mednyánszky

László:

Csavargófej,

1908-1910.

MNG



Burne-Jones:  
A rémfej,  
1887.  
Stuttgart,  
Staatsgalerie





Henri de Toulouse-Lautrec: Ezek a hölgyek, 1895. (SZM)



Toulouse-Lautrec:  
Jane Avril  
litografía,  
1893.  
Albi,  
Musée d'Albi





Lautrec:  
A toalett  
1896  
Párizs,  
Musée d'Orsay



Klimt:  
Judith, 1901.  
Bécs,  
Österreichische Galerie





Klimt:  
Csók



Egon Schiele:  
Önarckép 1910.





Egon Schiele:  
Akt



Edvard Munch:  
Sikoly, 1893.

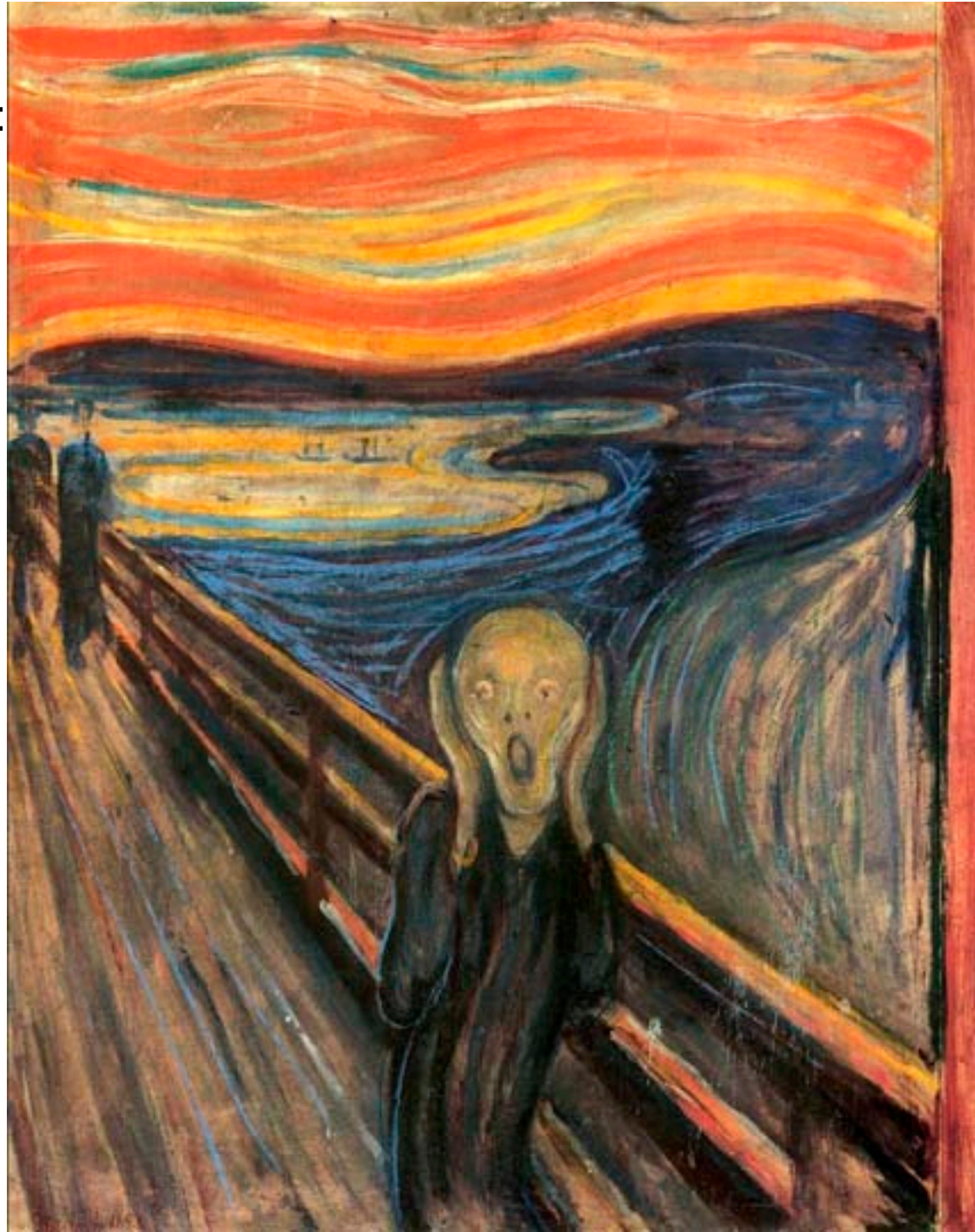



Munch:  
Madonna,  
1894.  
National Gallery  
of Oslo



Amadeo Modigliani:  
Leányfej  
Jeanne Hébuterne  
arcképe szemből,  
1918. (Bern, mgt.)





Rippl-Rónai József:  
Kalitkás nő,  
1892. MNG

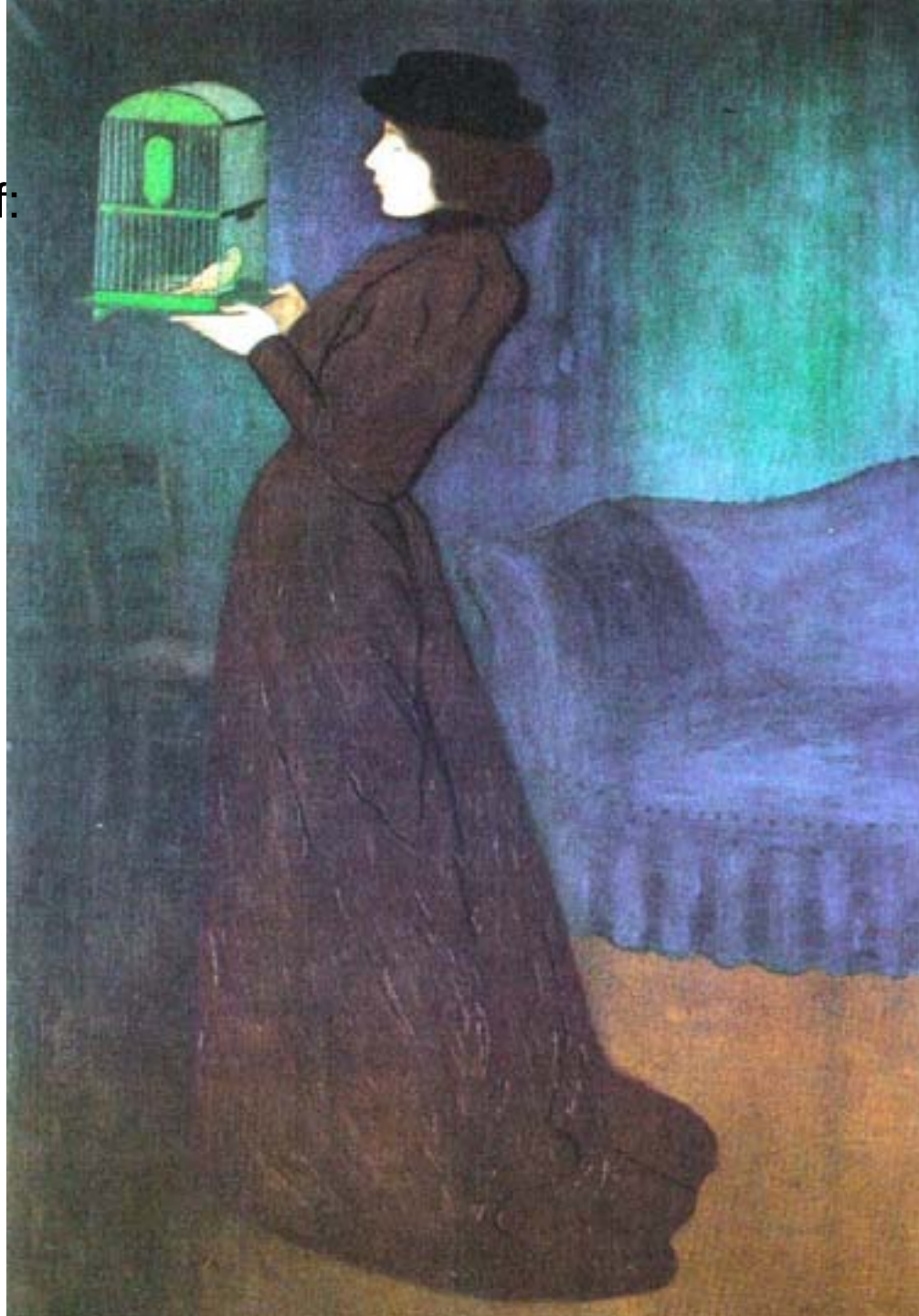

Ferenczy Károly:  
Madárdal,  
1893. MNG





Gulácsy Lajos:  
A varázsló kertje,  
1904. MNG



Csontváry Kosztka Tivadar: Zarándoklás a cédrusokhoz  
Libanonban, 1907. (MNG)

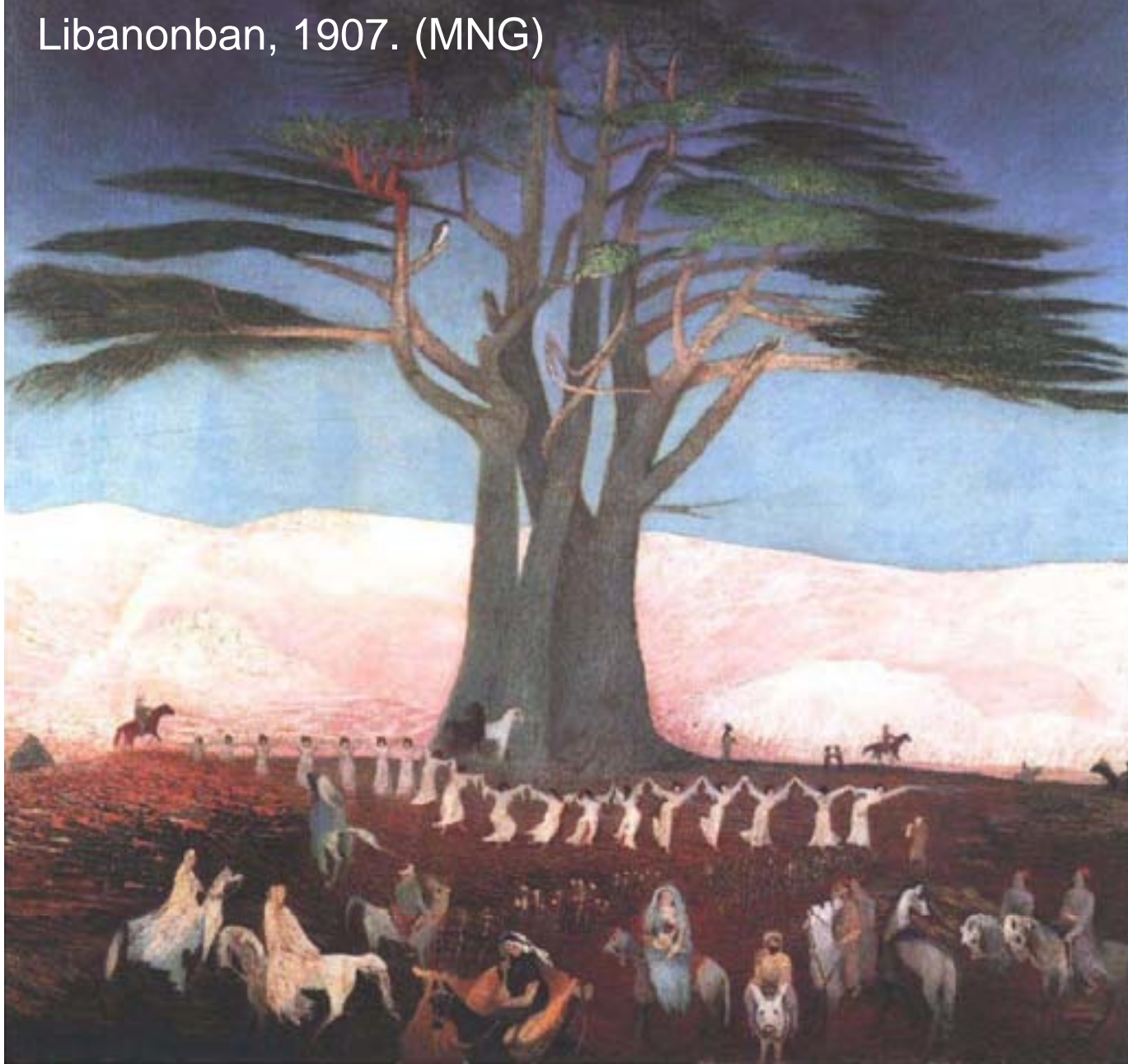





425

Csontváry Kosztka Tivadar: Taormina, (MNG)



Csók István: A keresztapa reggelije, 1932. (MNG)





Rippl-Rónai József-Róth Miksa:

Az Ernst Múzeum

üvegablaka,

1912. Budapest

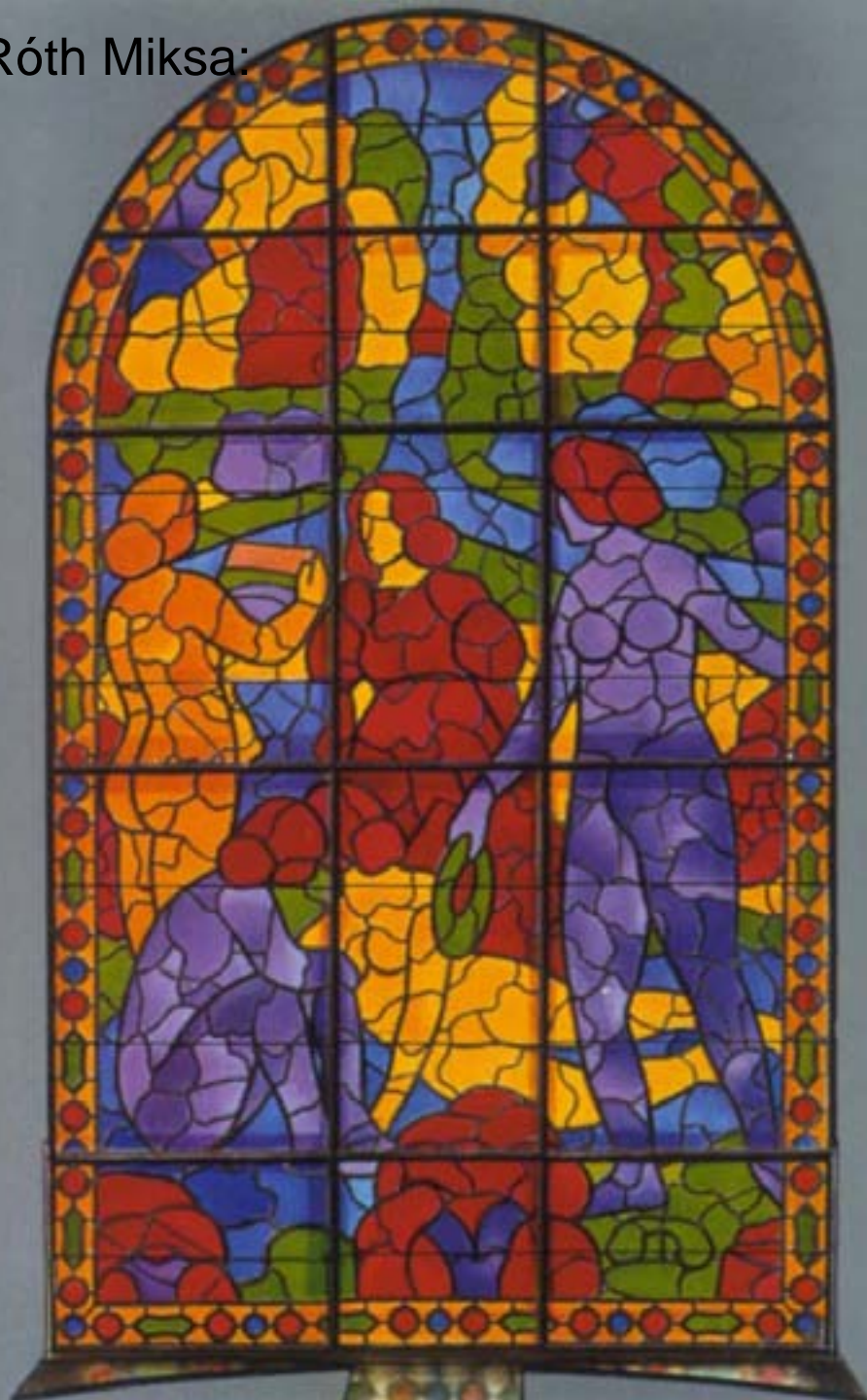

Thonet bútorok, 1851-től (pl. Thonet hajlított hintaszéktípusa 1860 vagy Thonet kerek ülésű standard széke, 1859. évi típus)





Henry van de Velde bútorai (pl. szecessziós szék és asztal 1895-ből)



A pécsi Zsolnay  
gyár egy tárgya  
a századfordulóról



430



# XX. SZÁZAD ELSŐ FELE

(Louis) Sullivan:  
Carson,  
Pirie és Scott  
áruház,  
1899-1904.  
Chichago





Behrens:  
Hoechst  
festékgyár,  
1920-1925.  
Berlin



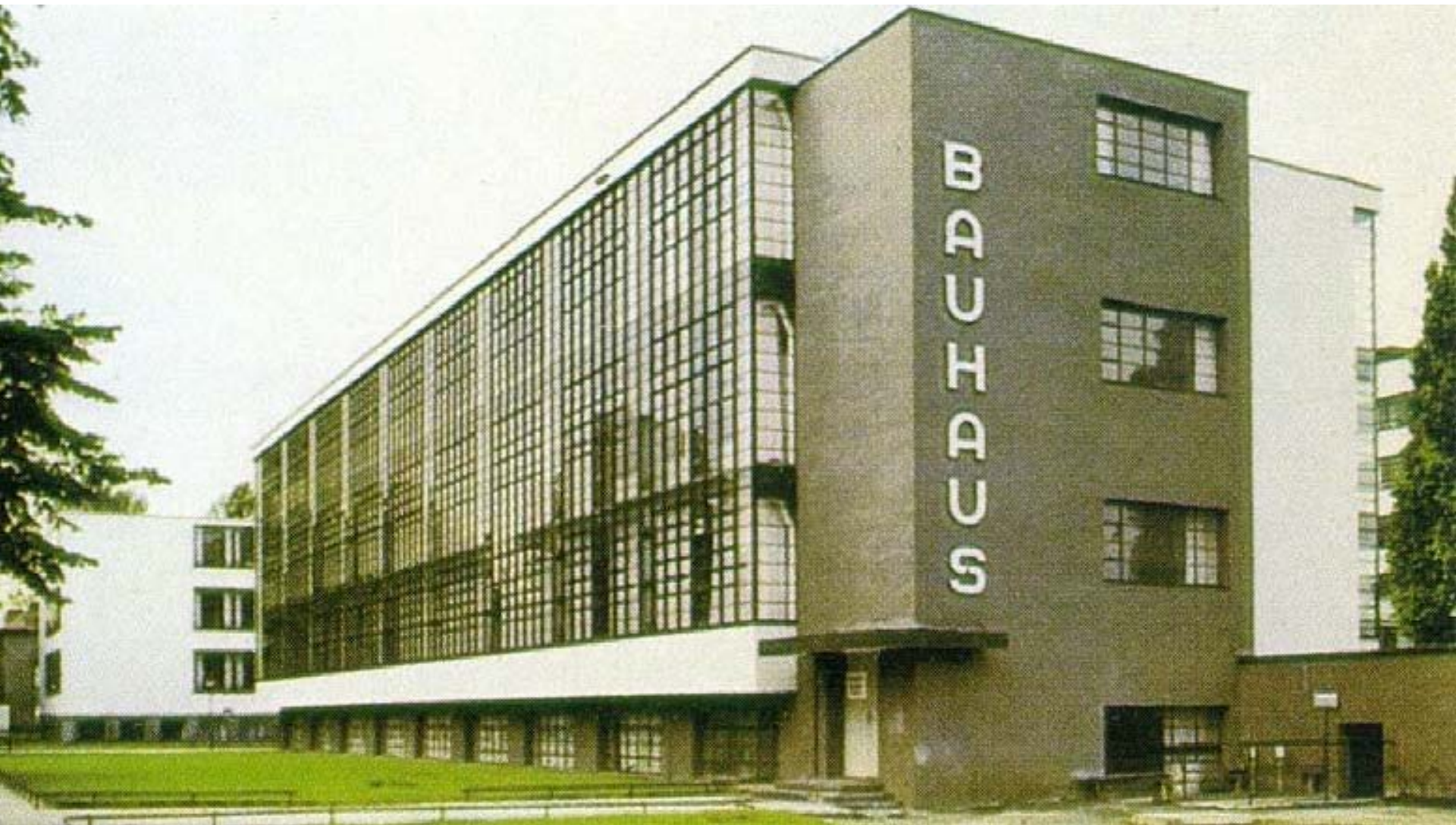

434 Walter Gropius: A Bauhaus központi épülete, 1925-1926. Dessau



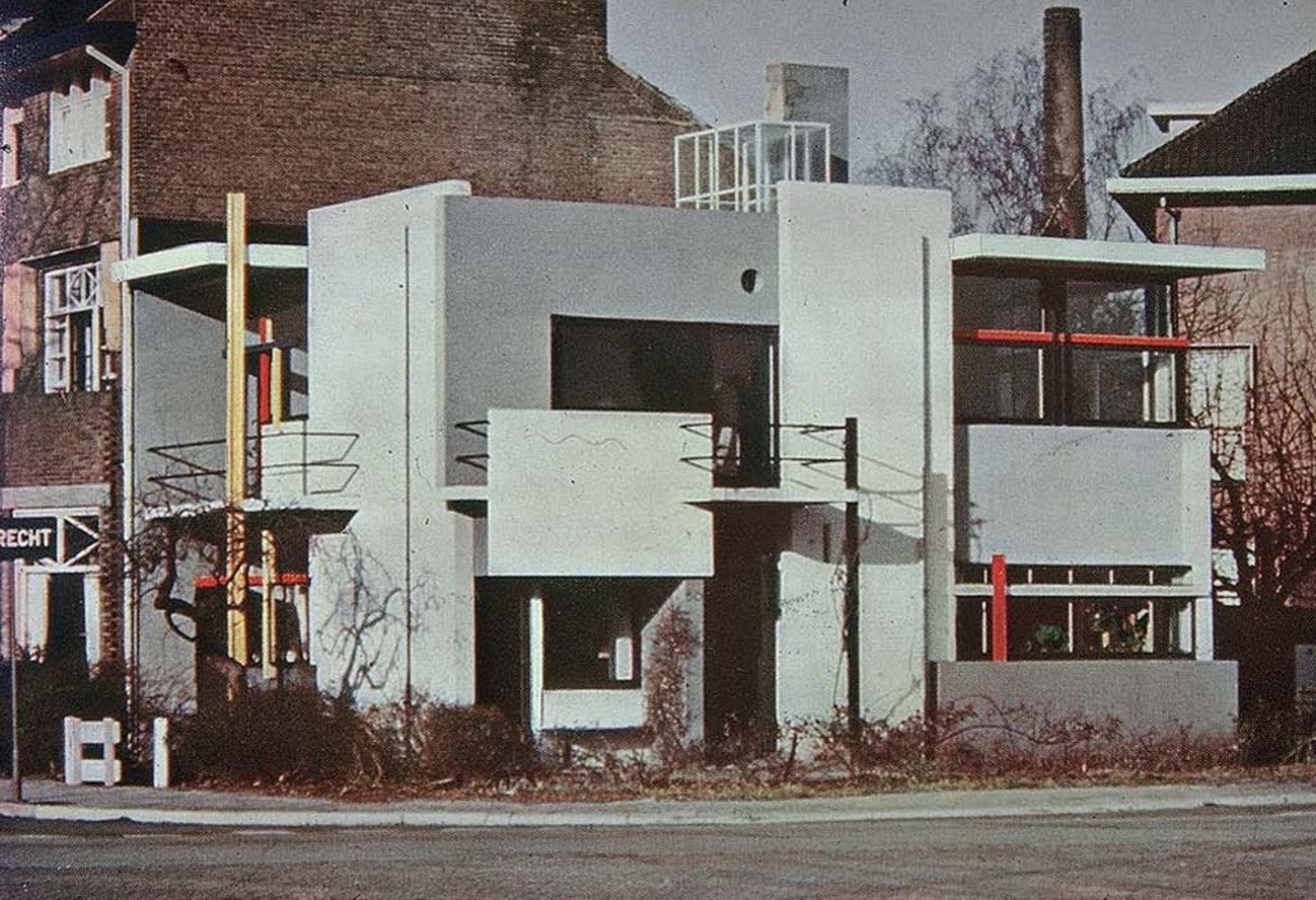

435 Gerrit Thomas Rietveld: Schroeder-ház, 1924. Utrecht



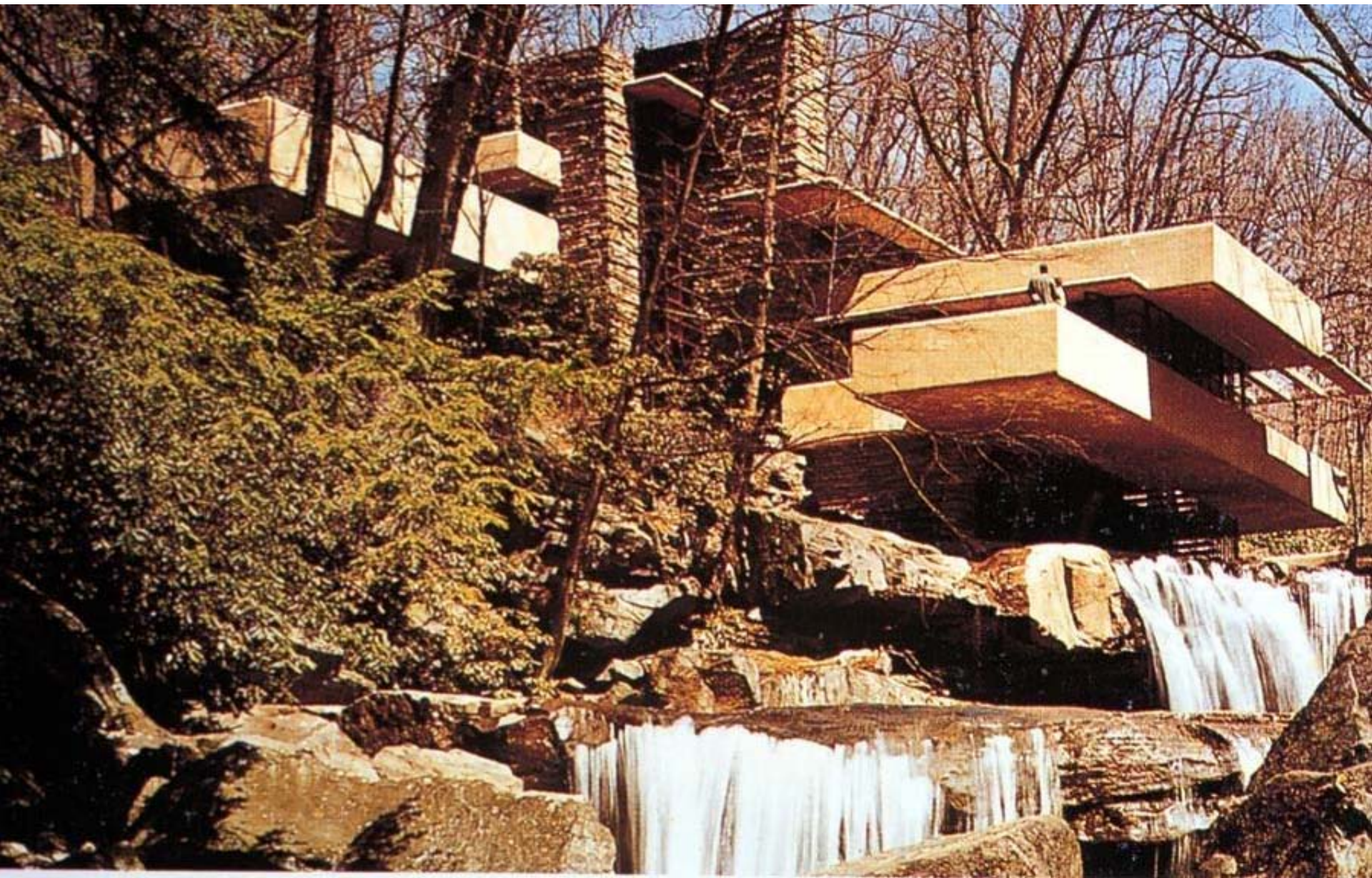

436 Frank Lloyd Wright: Vízesház, 1936. Bear Run (Pennsylvania)



Hajós Alfréd: Margitszigeti Sportuszoda, 1930.  
Budapest



Molnár Farkas:  
Társasház,  
1936.  
Budapest





Maurice de Vlaminck: A vörös fák, 1906. Párizs, Musée National d'Art Moderne

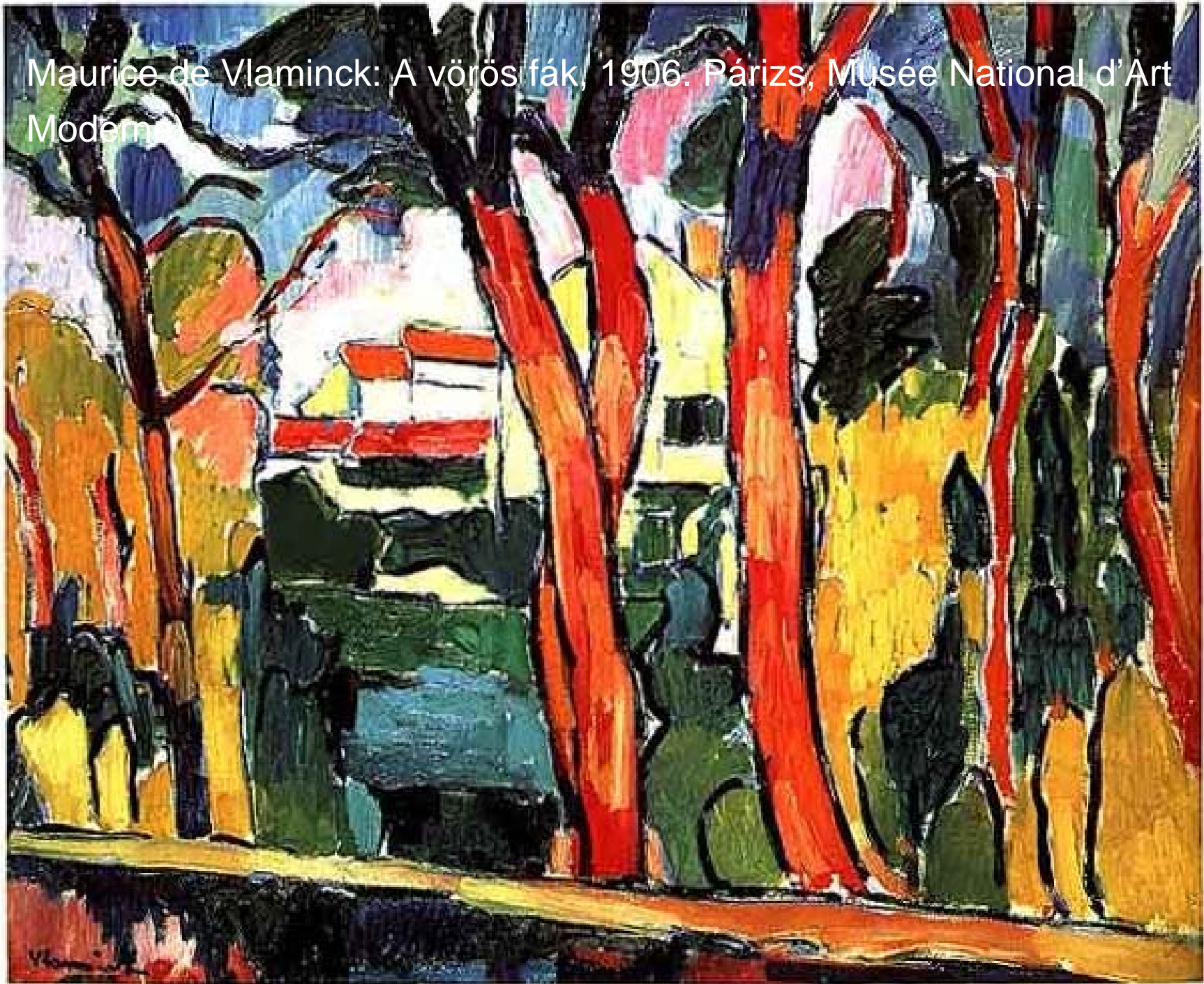

Henri Matisse: A vörös desszert, 1908. Szentpétervár, Ermitázs







441 Matisse: A tánc, 1910. Ermitázs, Szentpétervár



Picasso: Az avignoni kisasszonyok, 1907. New York, Modern Art

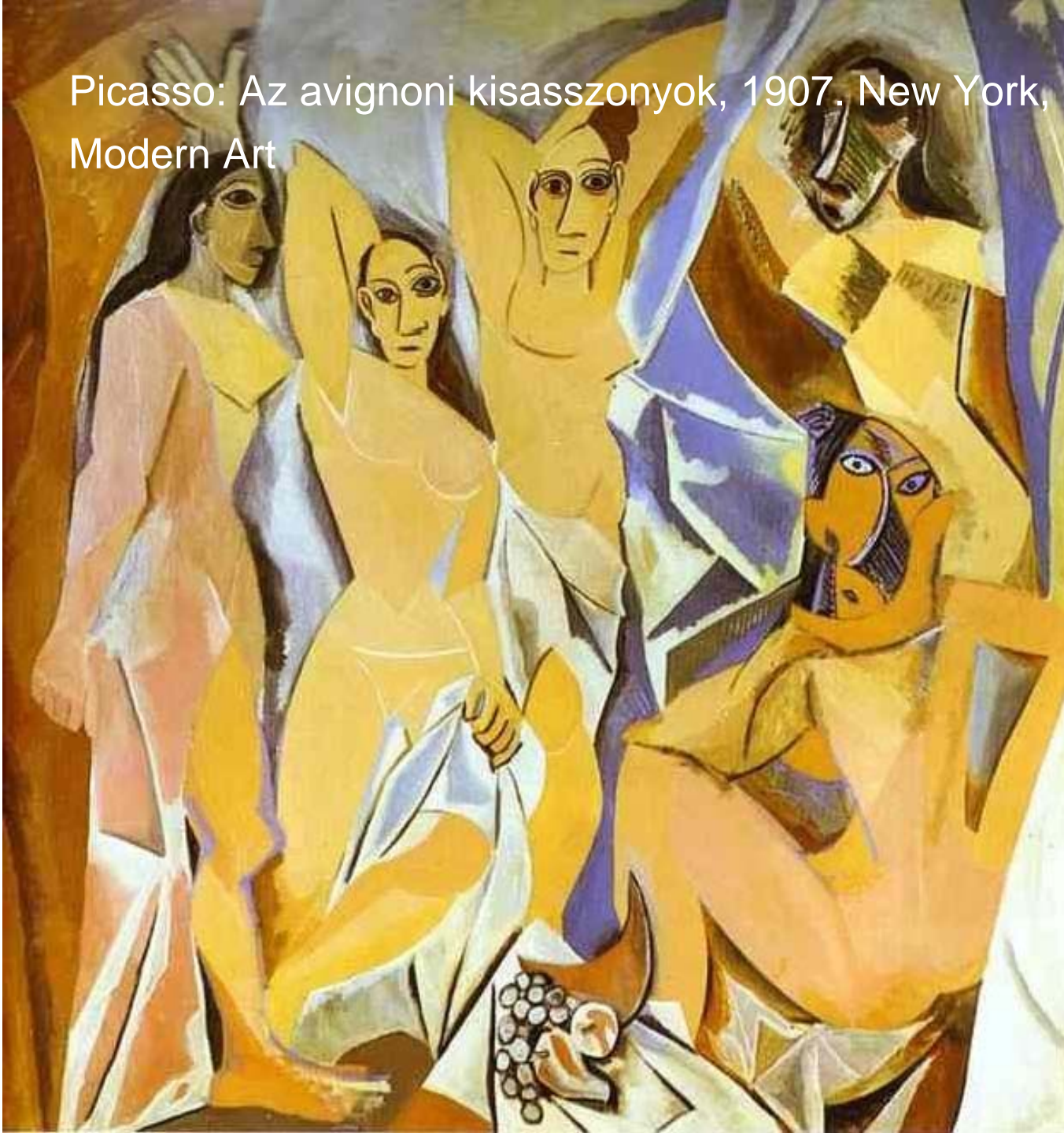





443

Picasso: Guernica, 1937. Barcelona

Braque:  
A portugál nő,  
1911.  
Basel,  
Kunstmuseum





Jean Gris:  
Kávéházi  
csomag,  
kollázs,  
1914.  
Ulm, Museum



Emil Nolde:  
Prófeta  
1912.

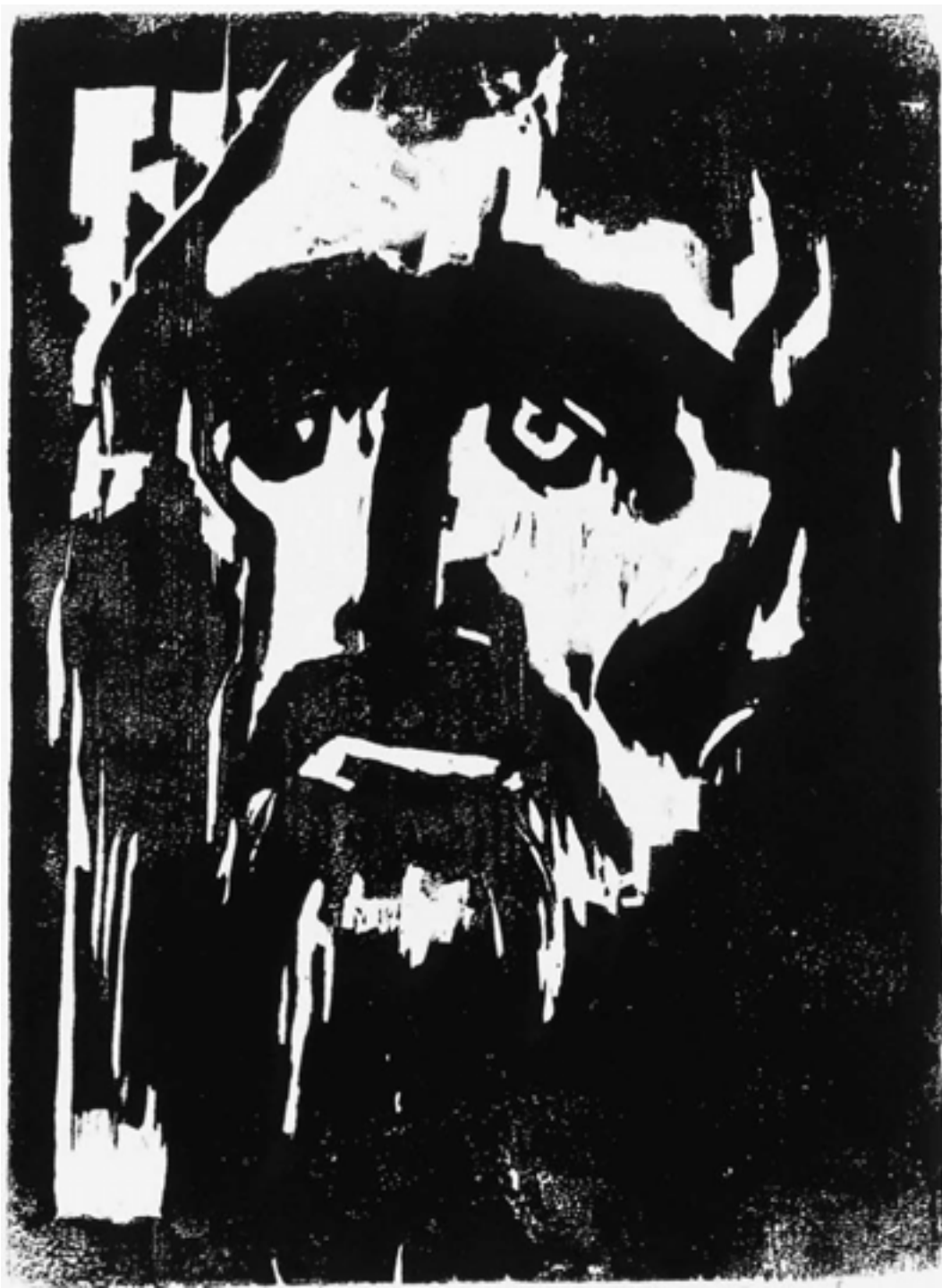



Franz Marc:  
Kék ló, 1911.  
München,  
Lenbachhaus

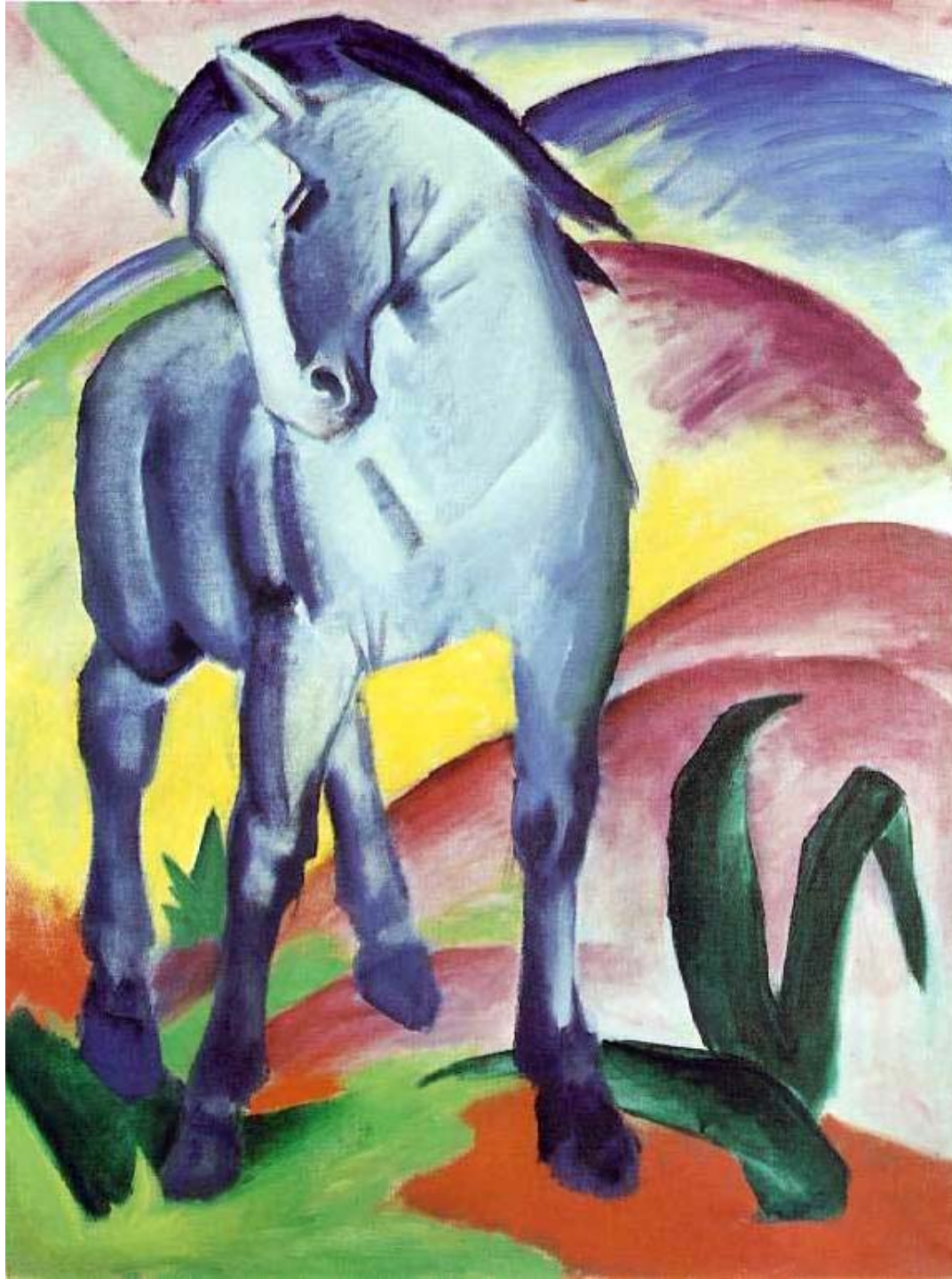





448 Franz Marc: Küzdő formák 1914.



Umberto Boccioni:  
Az izmok dinamizmusa,  
bronz, 1913.  
New York,  
Museum of Modern Art





Balla: Pórázon vezetett kutya



John Heartfield:  
Hurrá!,  
festmény, 1935.



**Hurrah, die Butter ist alle!**

Goerring in seiner Hamburger Rede: „Erz hat stets ein Reich stark gemacht,  
Butter und Schmalz haben höchstens ein Volk fett gemacht“.

Jean Arp:  
Konfiguráció  
1927.





Raoul Hausmann: Mechanikus fej, 1919.



Duchamp:  
A nagy üveg  
1915-1923.

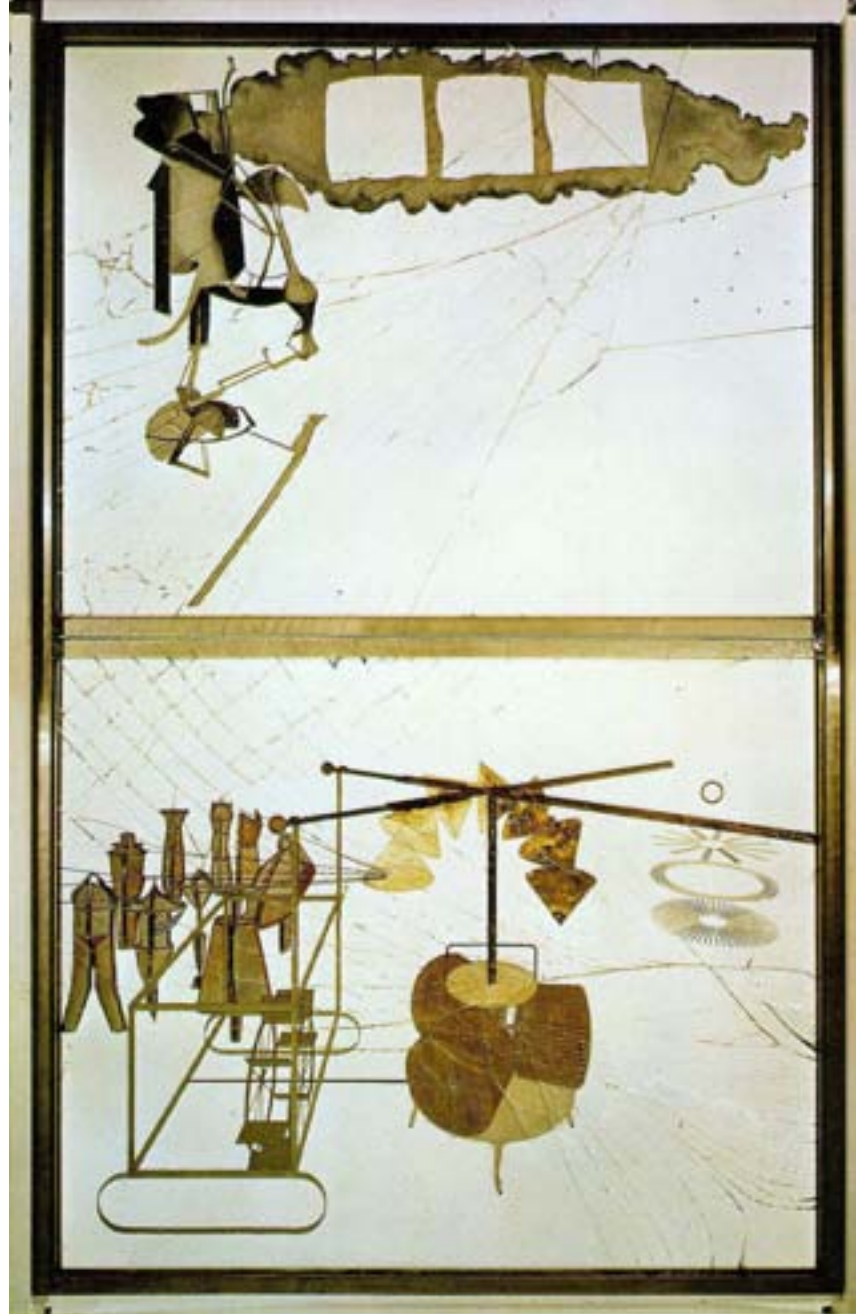



Duchamp:  
Lépcsőn lemenő akt,  
1912.  
Philadelphia,  
Museum of Modern Art



Duchamp:  
Forrás,  
1917.



456



Carlo Carra:  
A metafizika  
múzsája  
1917.





458

Constantin Brancusi: Alvó Múzsa, 1916. Párizs, Musée d'Art



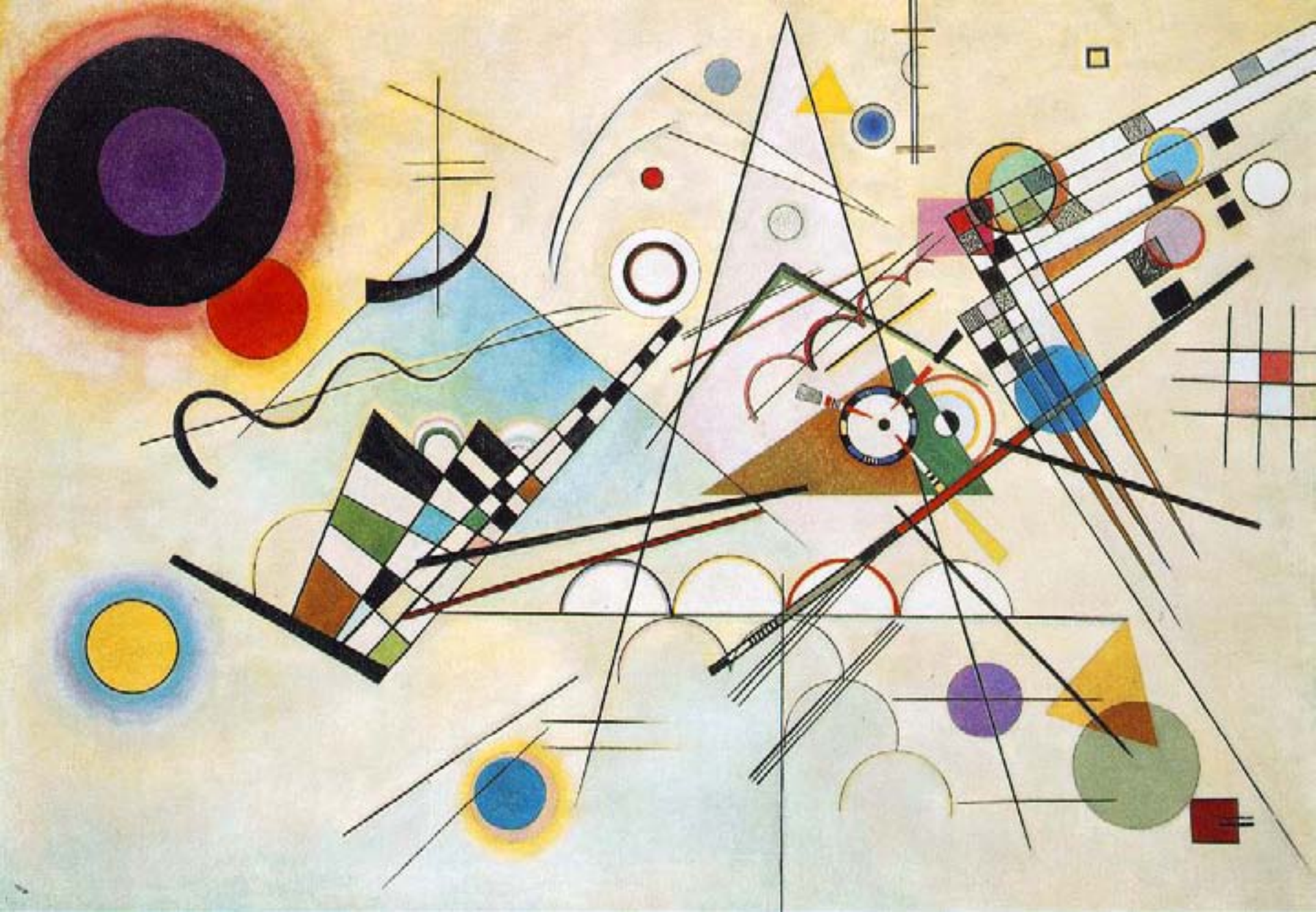

459 Kandinszkij: Kompozíció VIII.





460 Vasziliy Kandinszkij: Sárga, piros, kék, 1925. Párizs, Nina Kandinszkij





461 Paul Klee: Őszi hely, akvarell, 1921. magántulajdon

Klee:  
A szép kertésznő





Klee: Halál és tűz 1940.

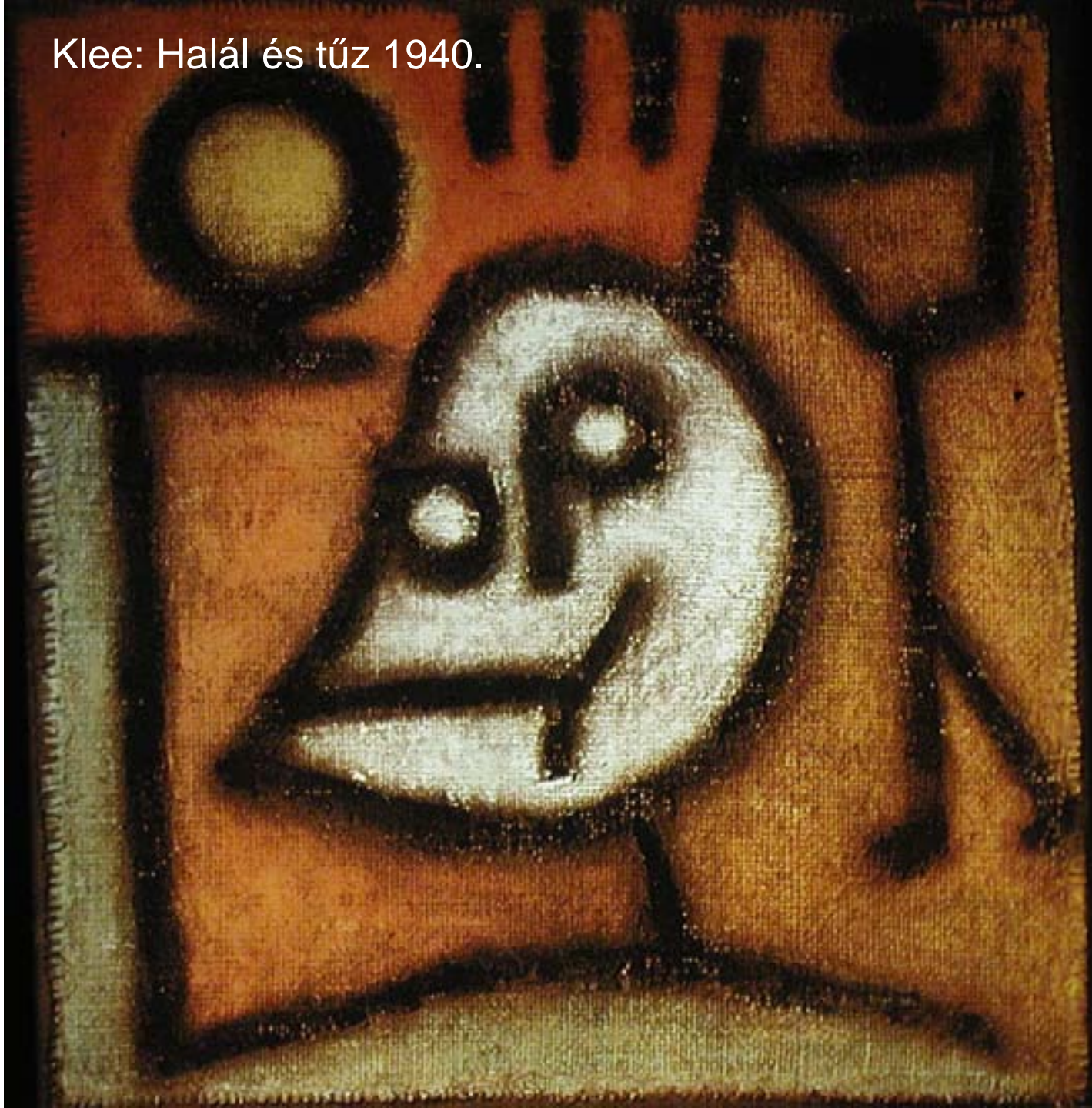

(Kazimir) Malevics: Vörös négyzet, 1914. (Szentpétervár, Russzkij Muzej)

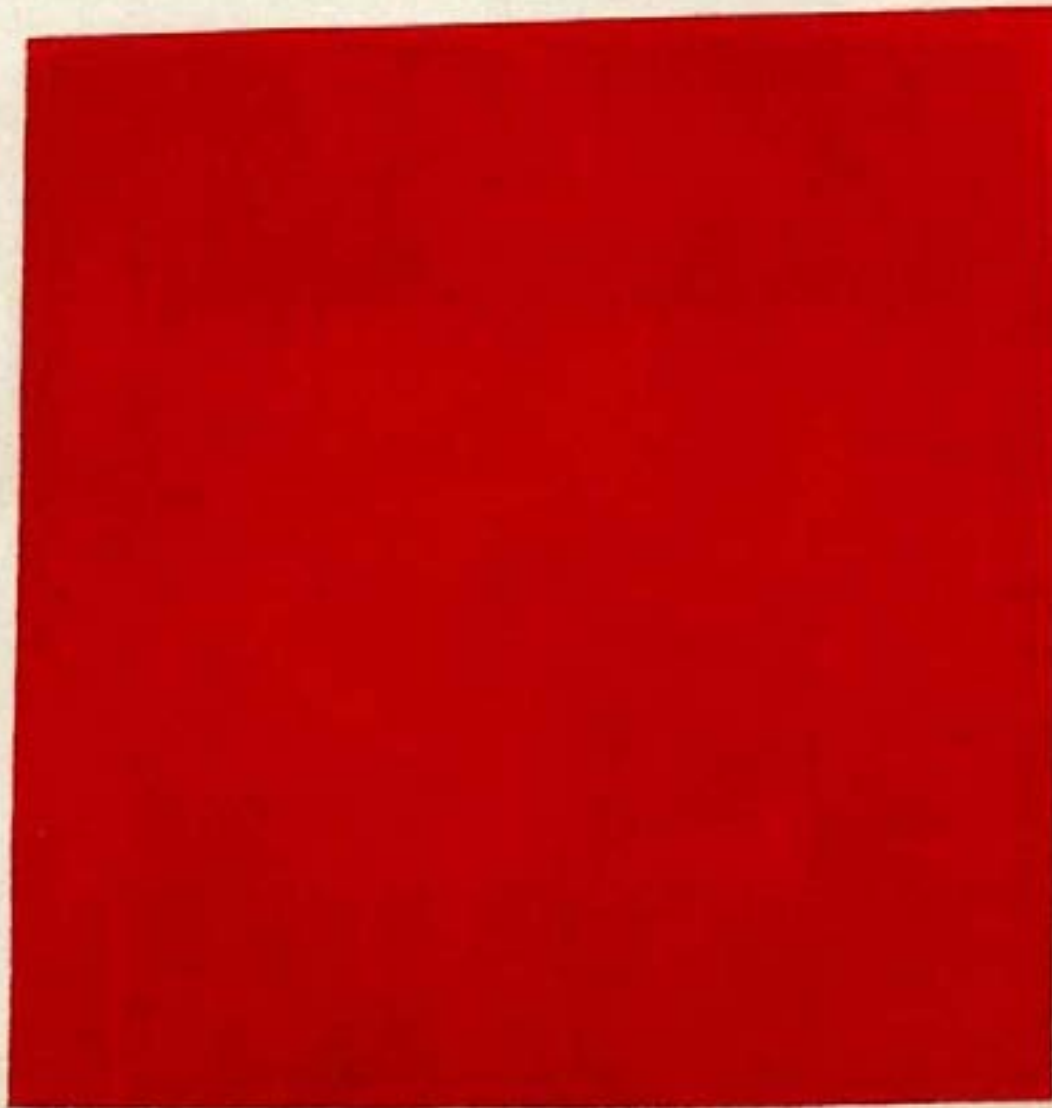



Mondrian:

Kompozíció:

Szürke struktúra színes síkokkal,  
1918. Zürich, Max Bill Gyűjtemény

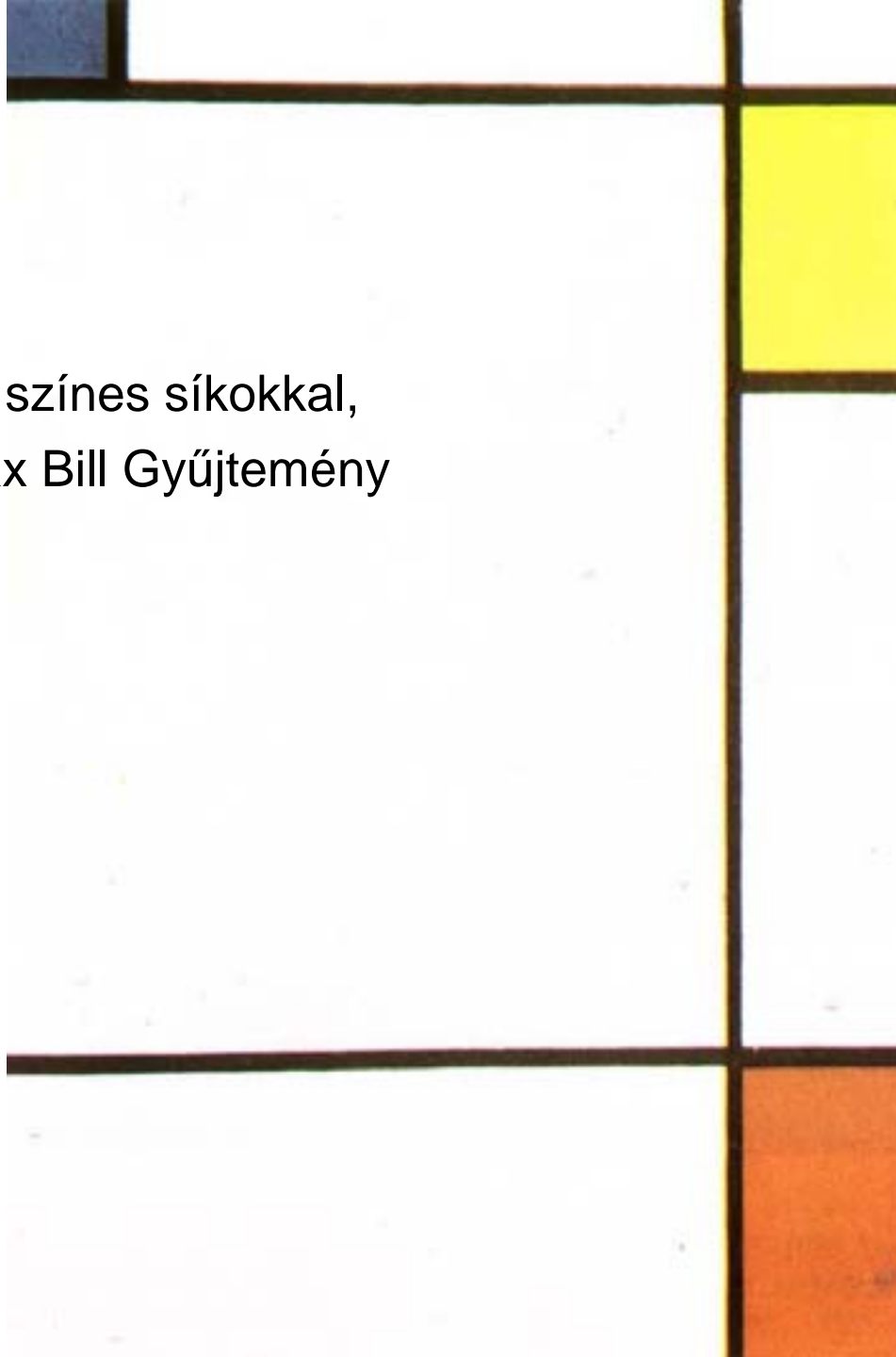

Mondrian:  
Kompozíció II. Piros, Kék, Sárga, 1930.





Man Ray: Lautréaumont mondásának illusztrációja, a Minotaure folyóiratból, 1933.

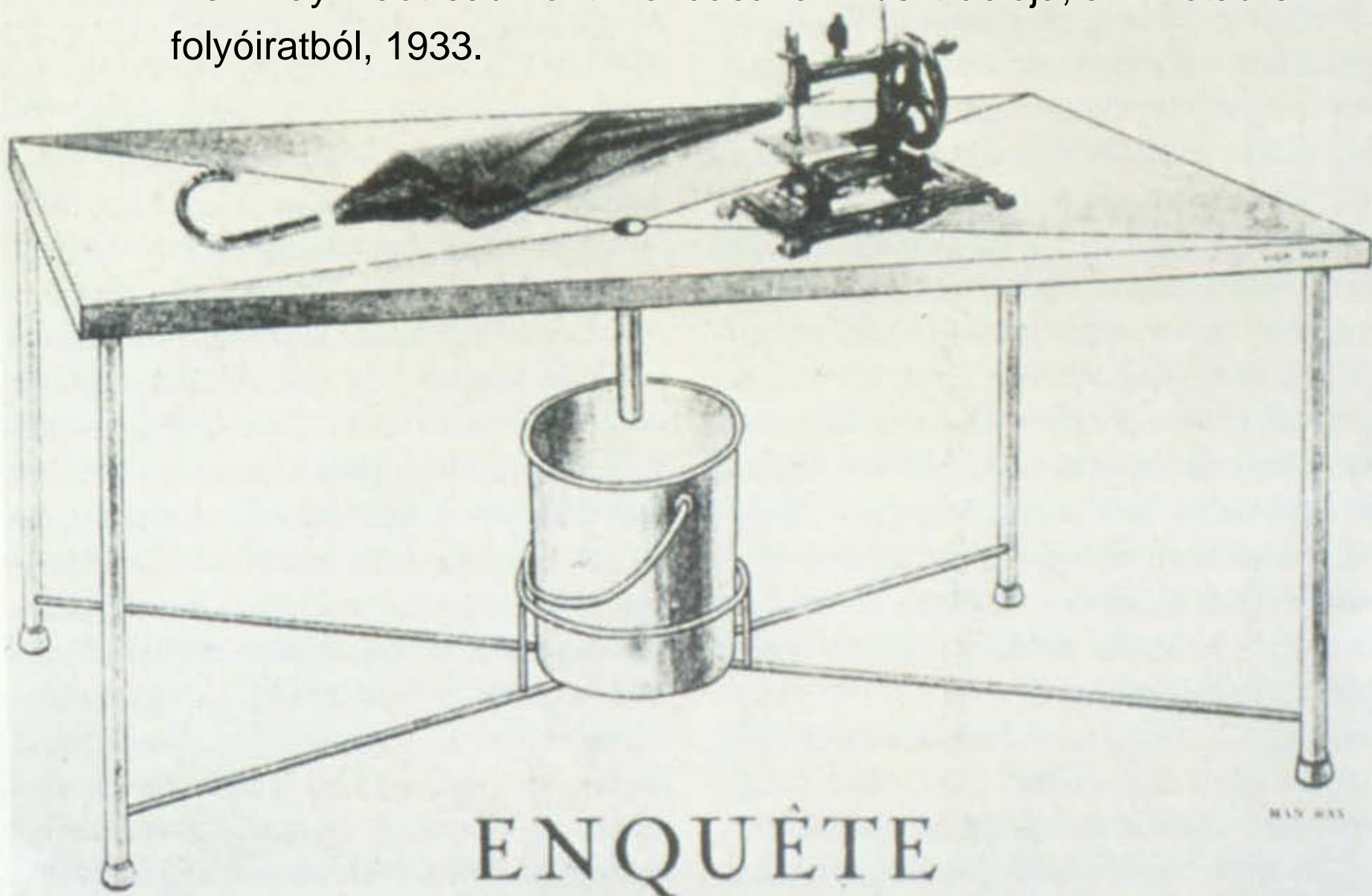

ENQUÊTE

MAN RAY

Marc Chagall: Én és a falu 1911.

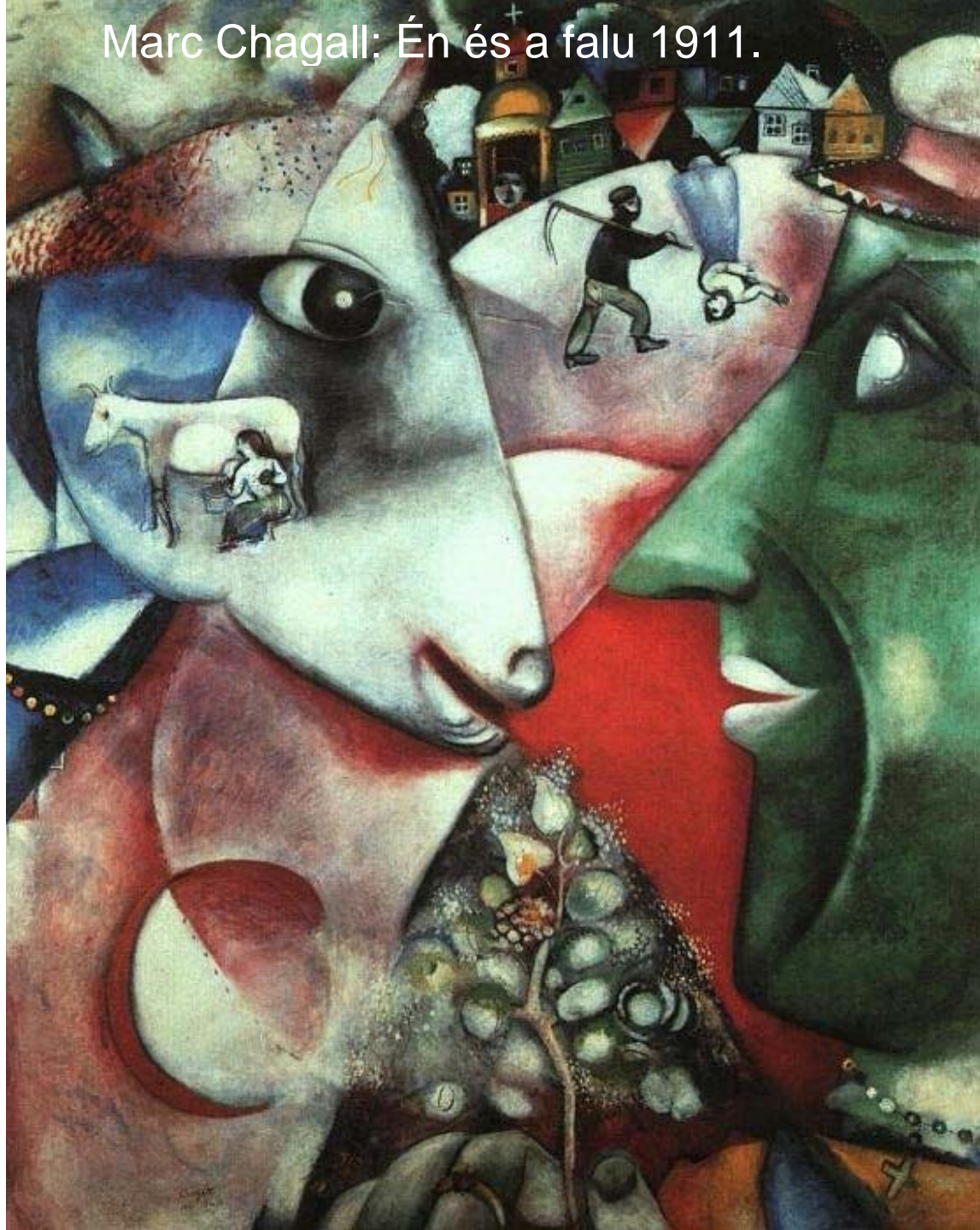



Magritte: A szóhasználat I. Ez nem pipa, 1928-1929. New York, mggy.



*Ceci n'est pas une pipe.*

Magritte:  
A megszárt idő  
1938.

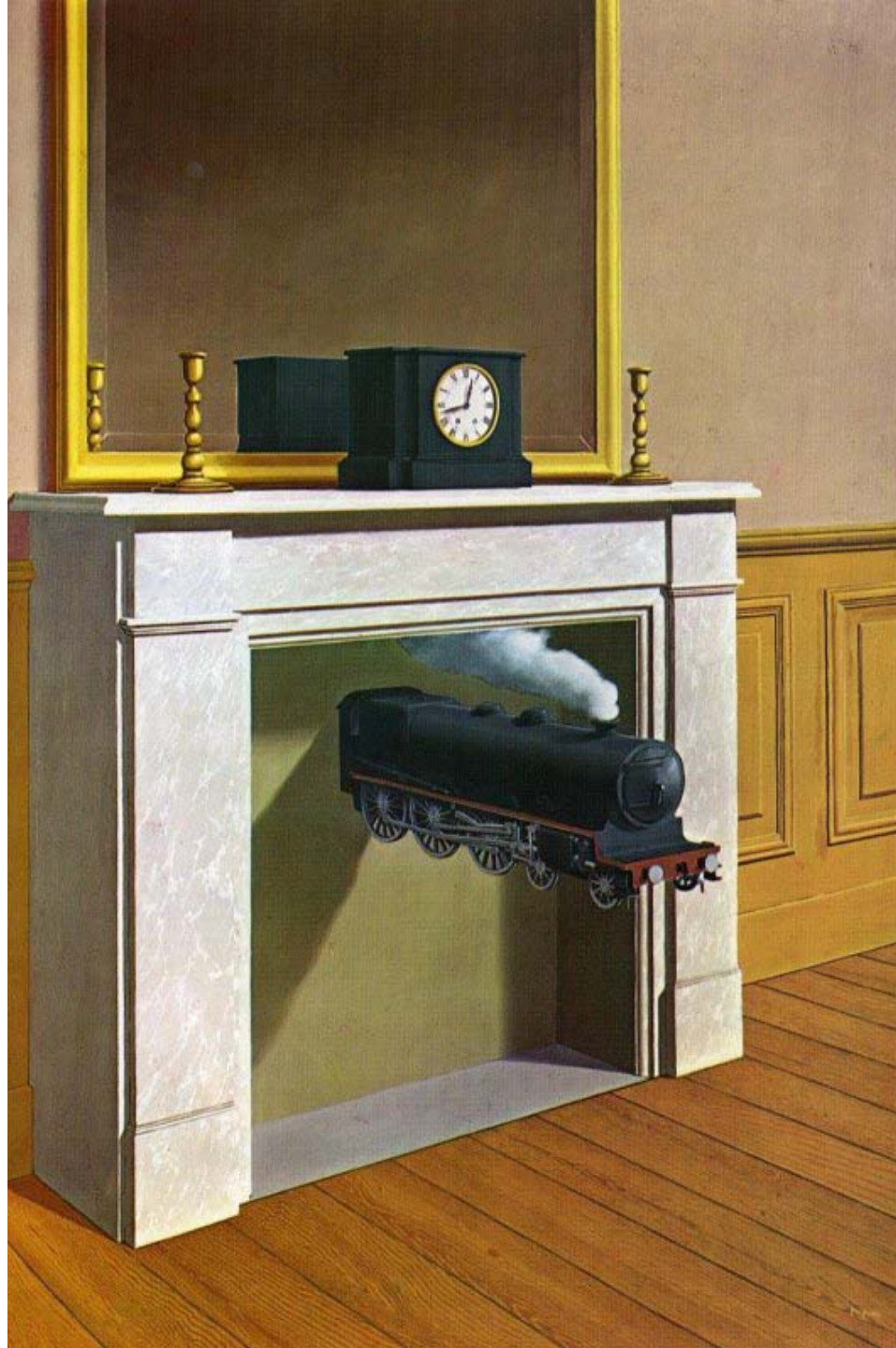



Giorgio de  
Chirico:  
Nyugtalanító  
múzsák  
1916.





Oppenheim: Prémes csésze, 1936. New York, Museum of Modern Art



Salvador Dalí: A polgárháború előérzete, 1936.  
Philadelphia Museum of Art



Nemes Lampérth  
József:  
Háttal álló női akt,  
1916.  
Budapest,  
MNG





Kassák Lajos:  
Képarchitektúra,  
fametszet, 1922.  
Pécs,  
Janus Pannonius  
Múzeum

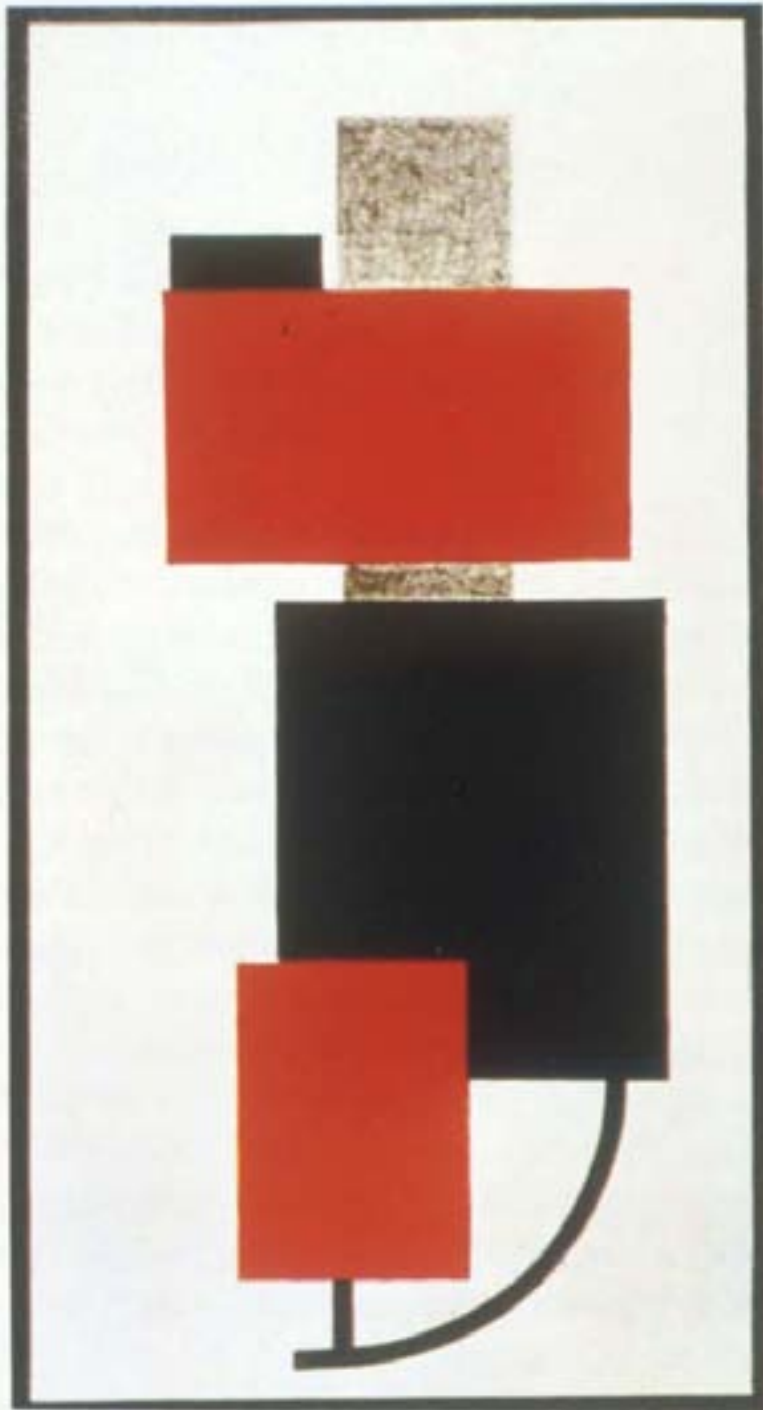

Moholy-Nagy  
László:  
Fényrekvizítum,  
1922-1930.  
Eindhoven,  
Stedelijk van  
Abbe Museum

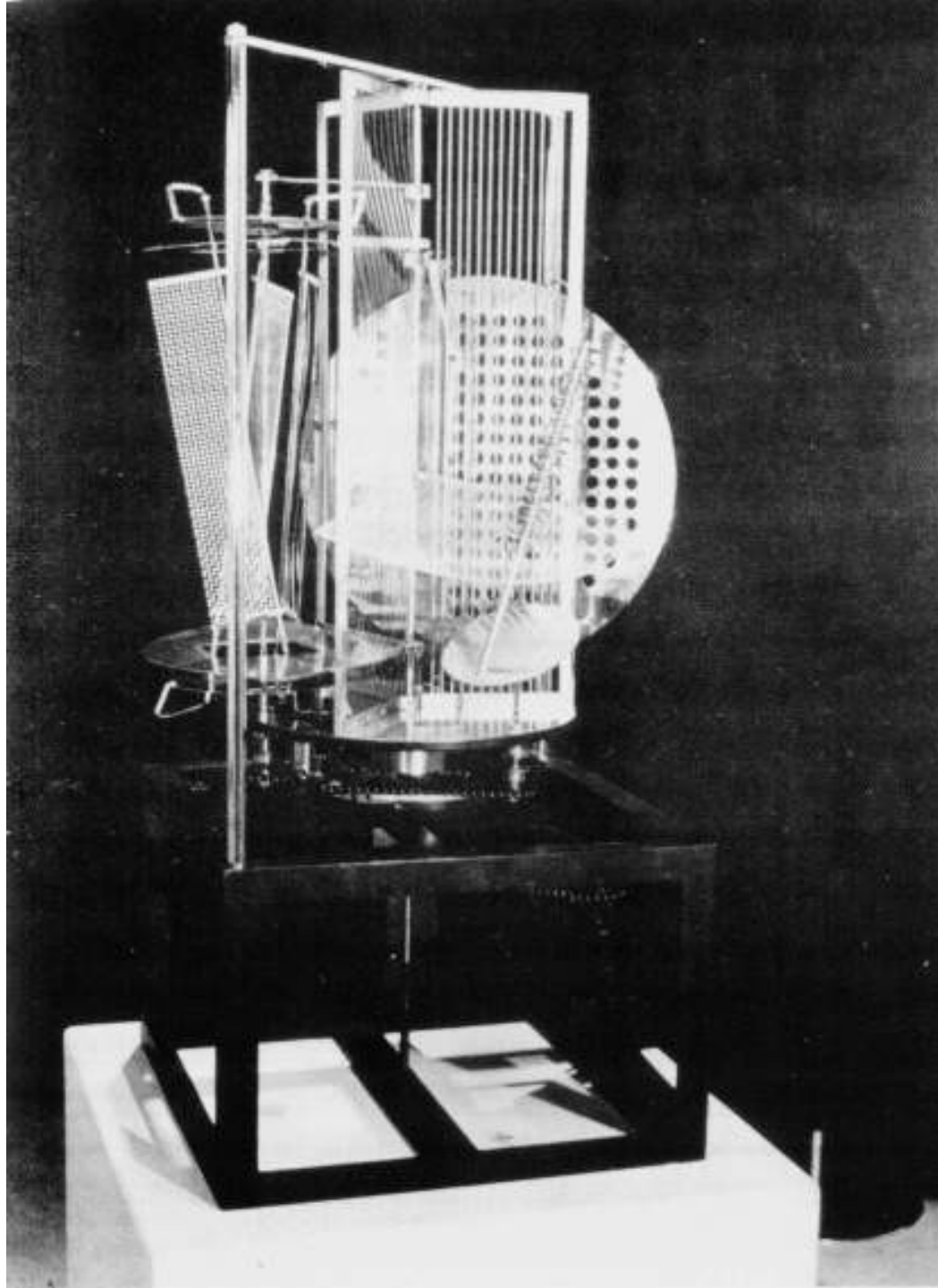



Szőnyi István: Zebegényi temetés, 1928. Zebegény, Szőnyi Múzeum.

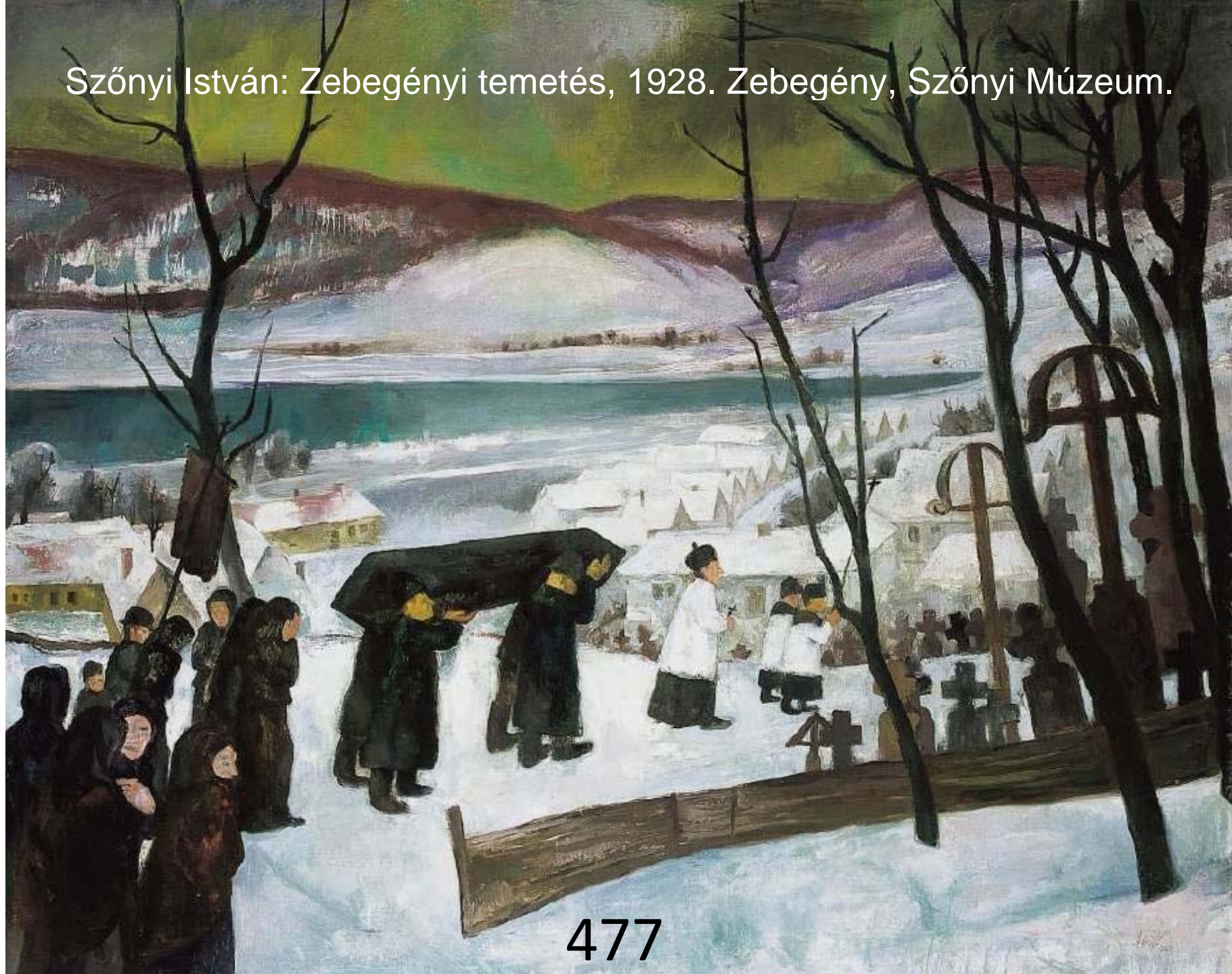



Bernáth Aurél: Tél, 1929. (mgt.) 478



Derkovits Gyula: Viharban, 1931. (mgt.)



Medgyessy Ferenc: Anya, 1932. (MNG)





Vajda Lajos: Ezüst gnóm, 1940. MNG







482

Egry József: Napfelkelte, 1940. MNG



Bauhaus-ban tervezett tárgy

pl. Brauer Marcel:

„funkcionalista” szék

1922

vagy

csőszék 1926

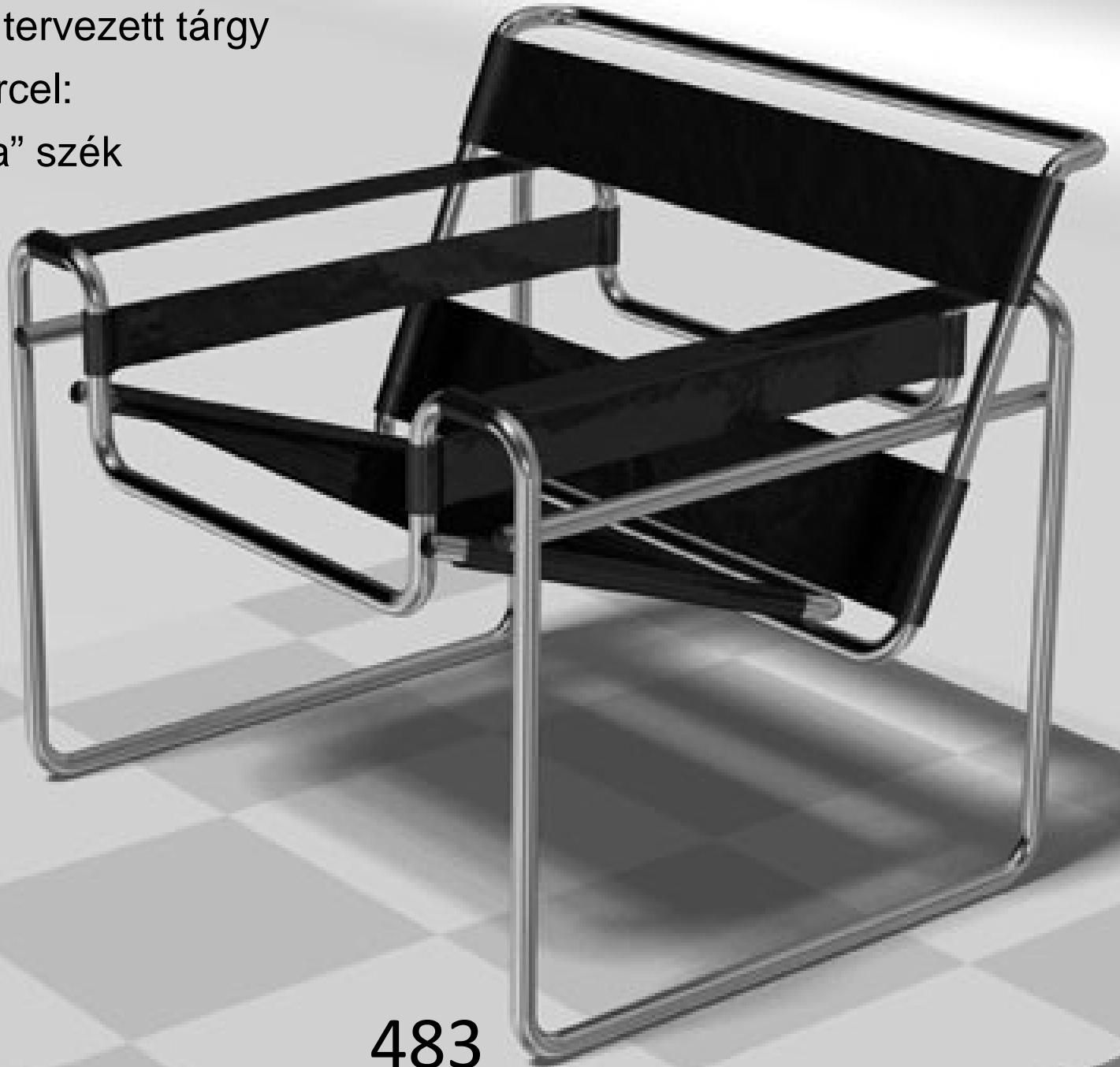

# A XX. SZÁZAD MÁSODIK FELE



Le Corbusier: Ronchamp-i kápolna, 1955.

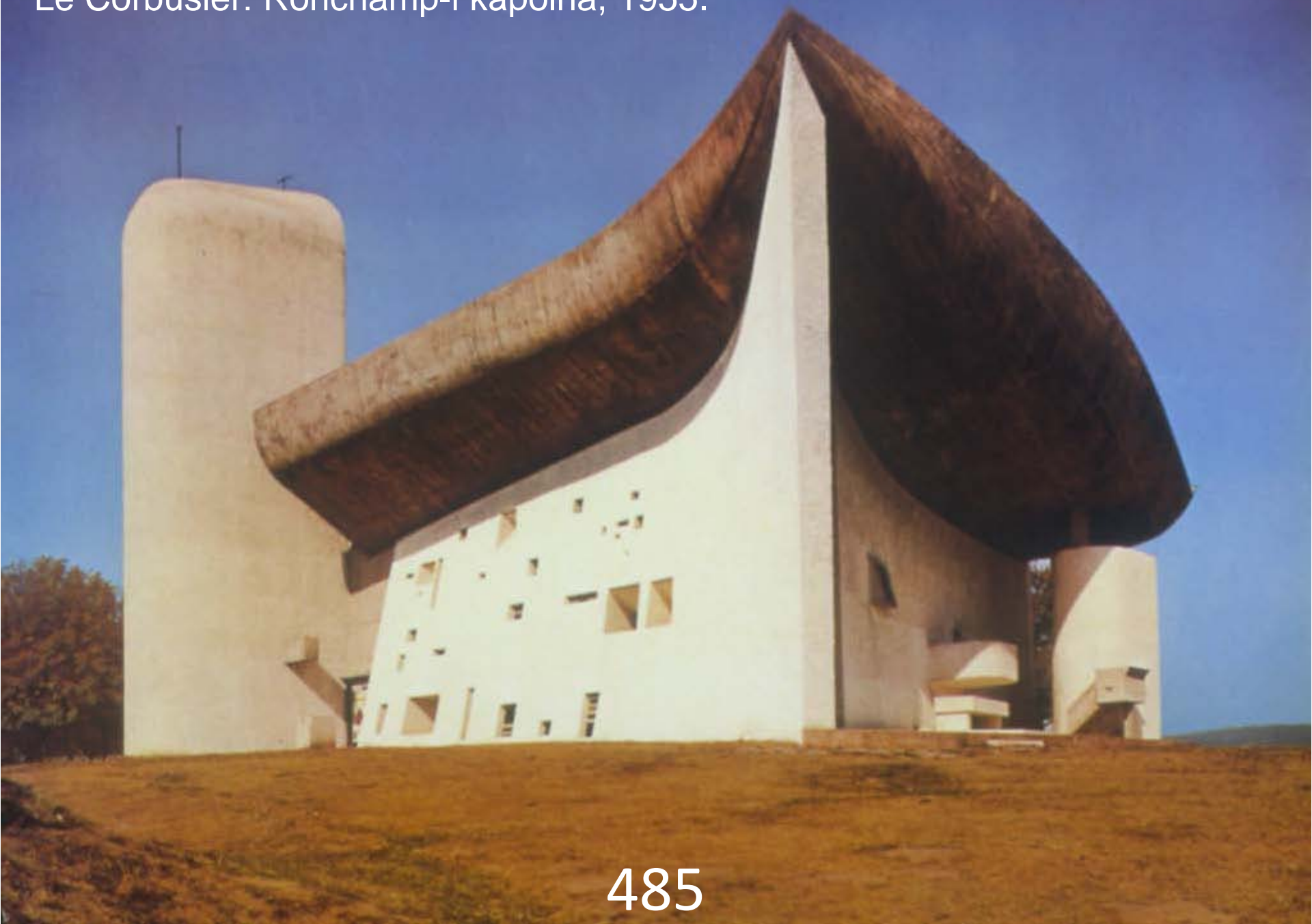

Alvar Aalto: Községháza,  
1949-1953. Säynätsalo

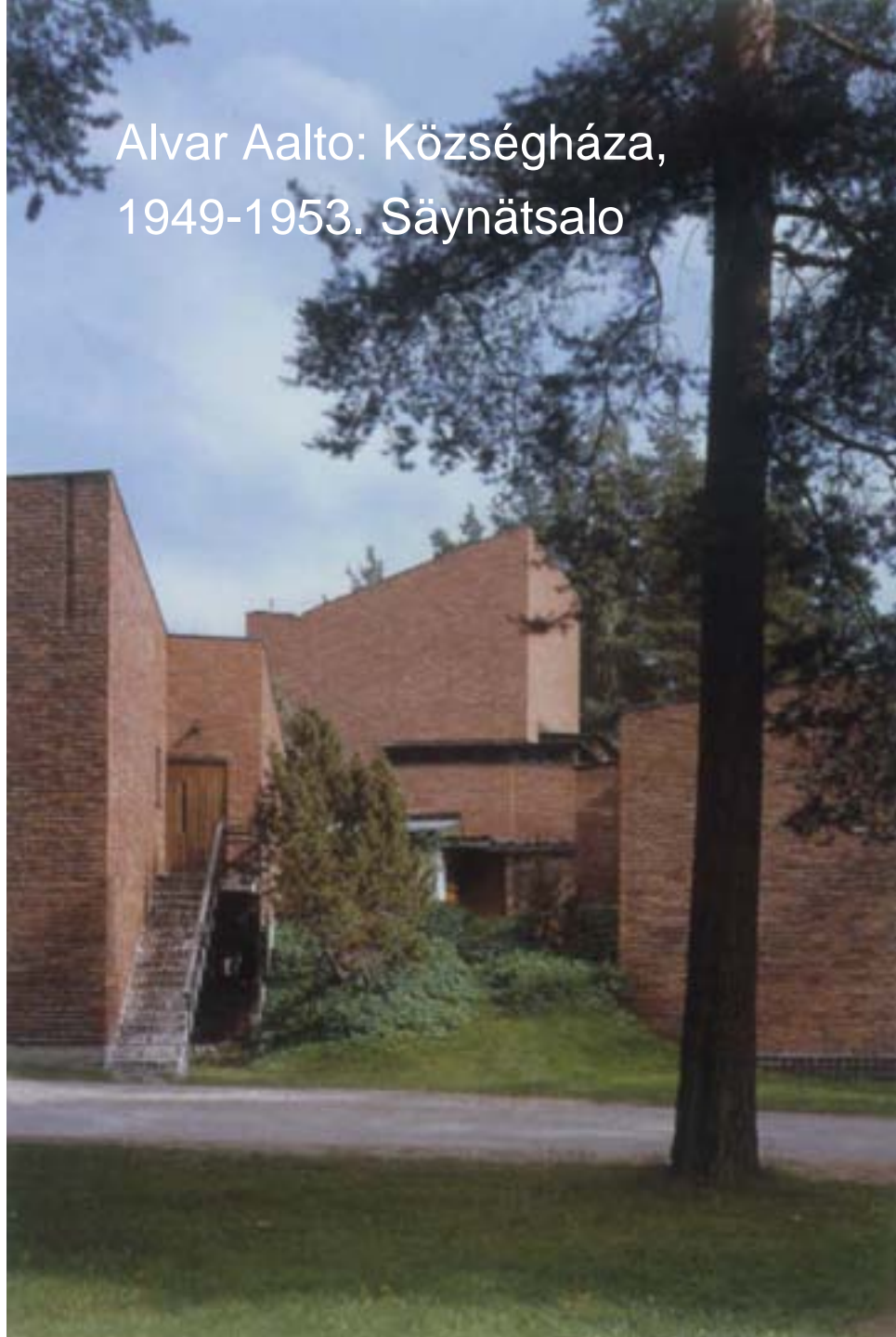



(Pier Luigi) Nervi: Sportcsarnok, 1956-1957. Róma



Frank Lloyd Wright:  
Guggenheim Múzeum,  
1946-1958. New York

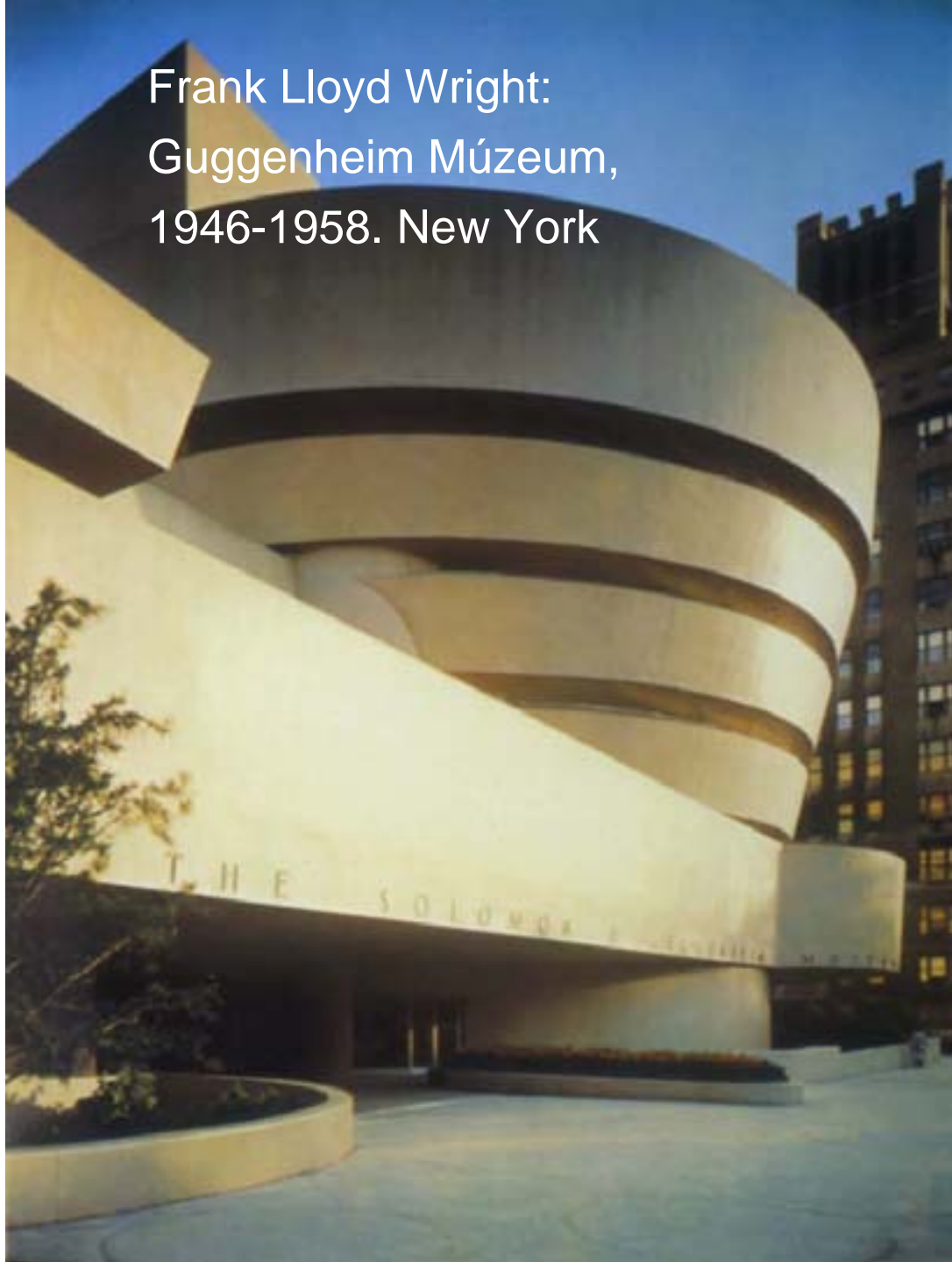



Tange Kenzo: Olimpiai csarnokok, 1964. Tokio

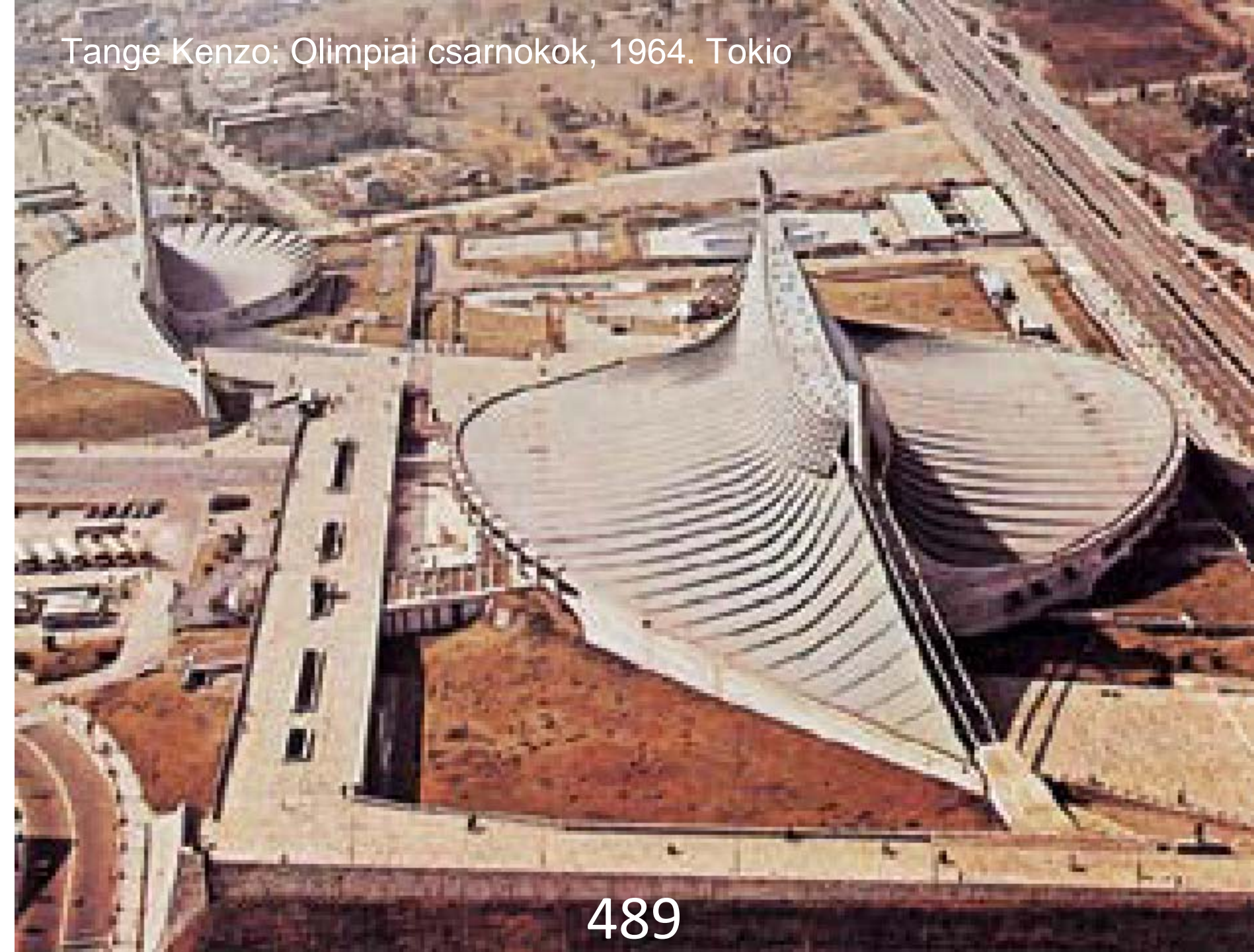



Renzo Piano - Richard Rogers: Pompidou központ, 1971-1977. Párizs

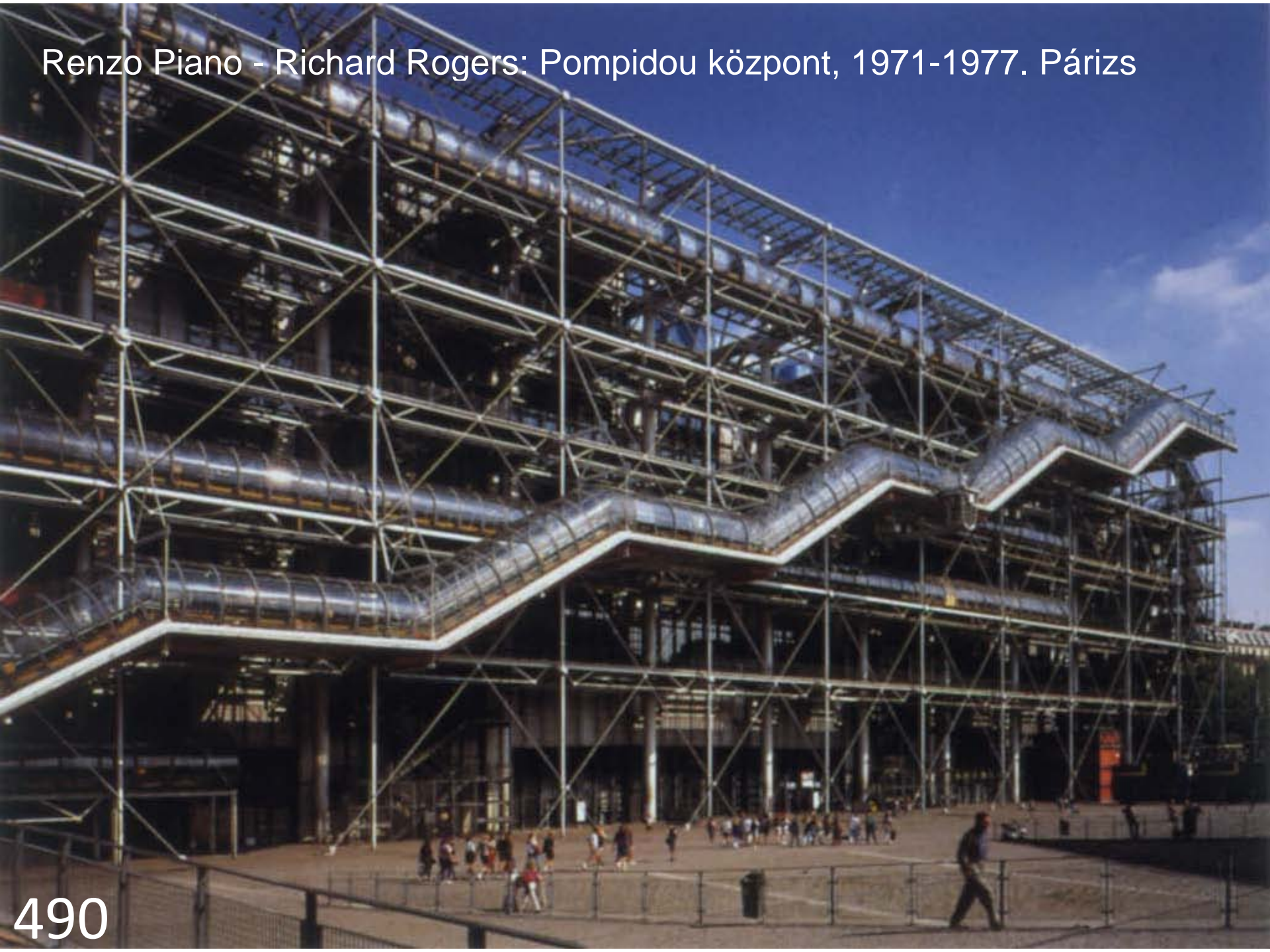



Friedrich Hundertwasser:  
Bécsi (Löwengassei) lakóház,  
1980-1982. Bécs

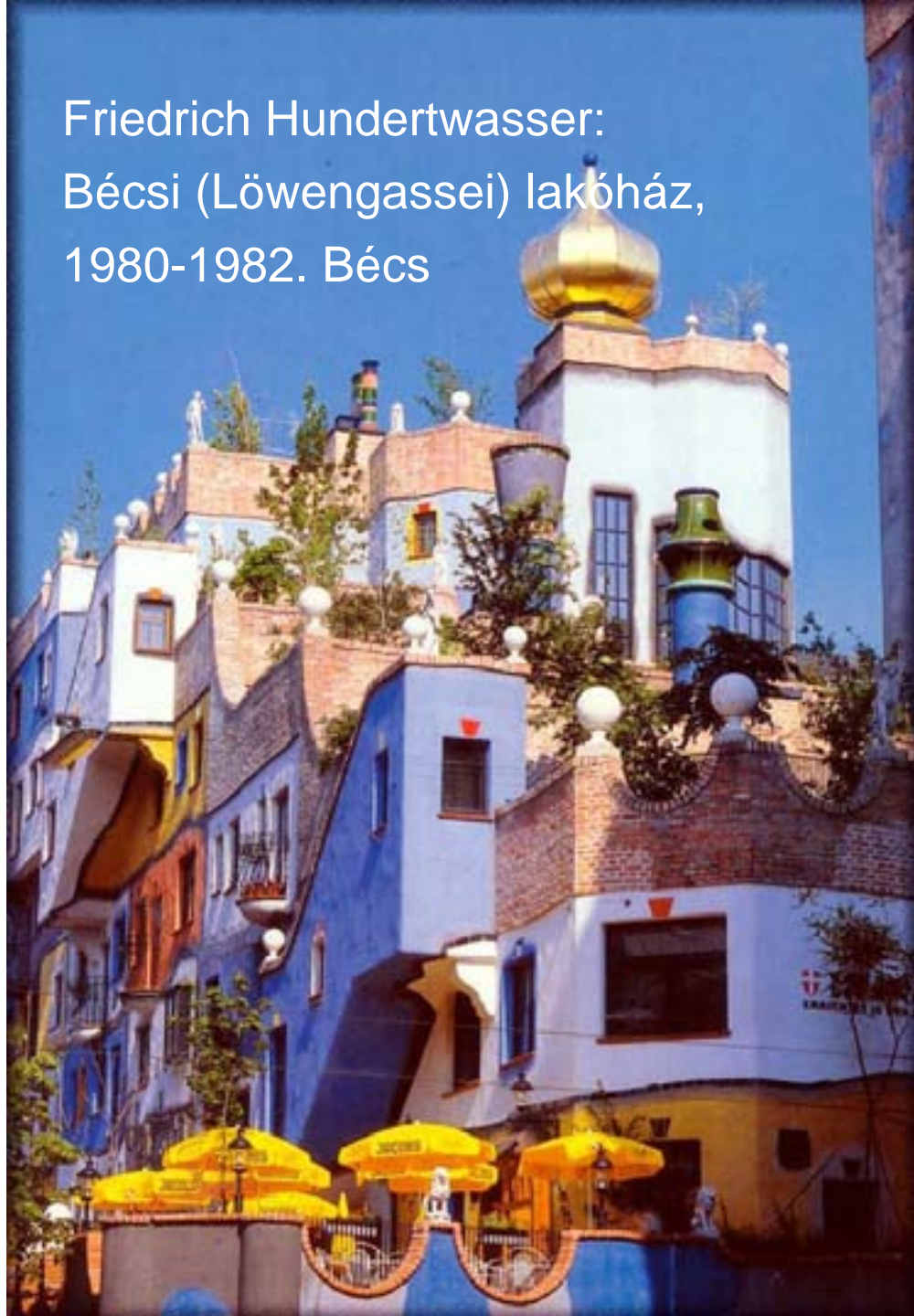

Makovecz Imre:  
A Művelődés Háza, 1976-1982. Sárospatak

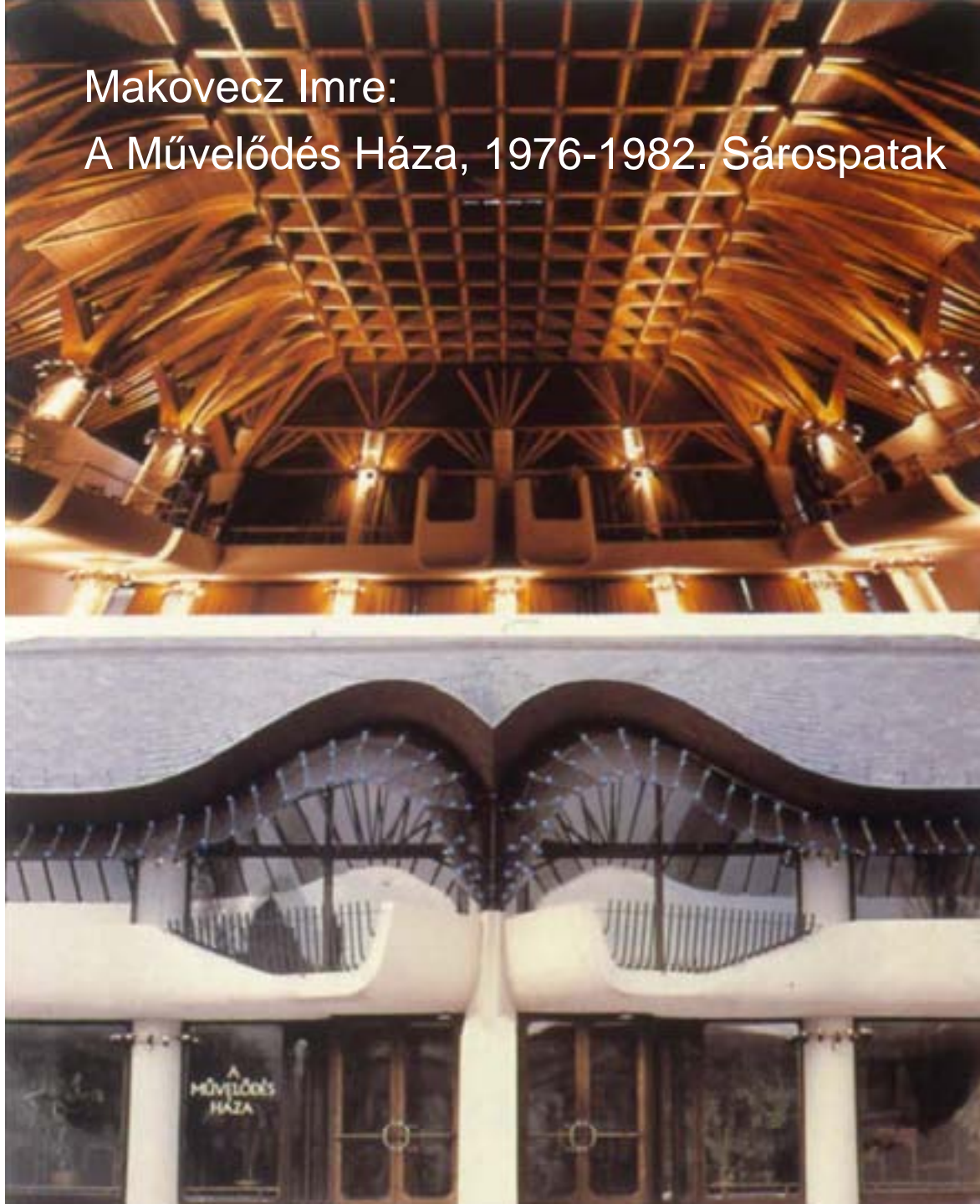



Marino Marini: Ló és lovas, fa,  
1949-1950. Zürich, Krayenbühl Gyűjtemény

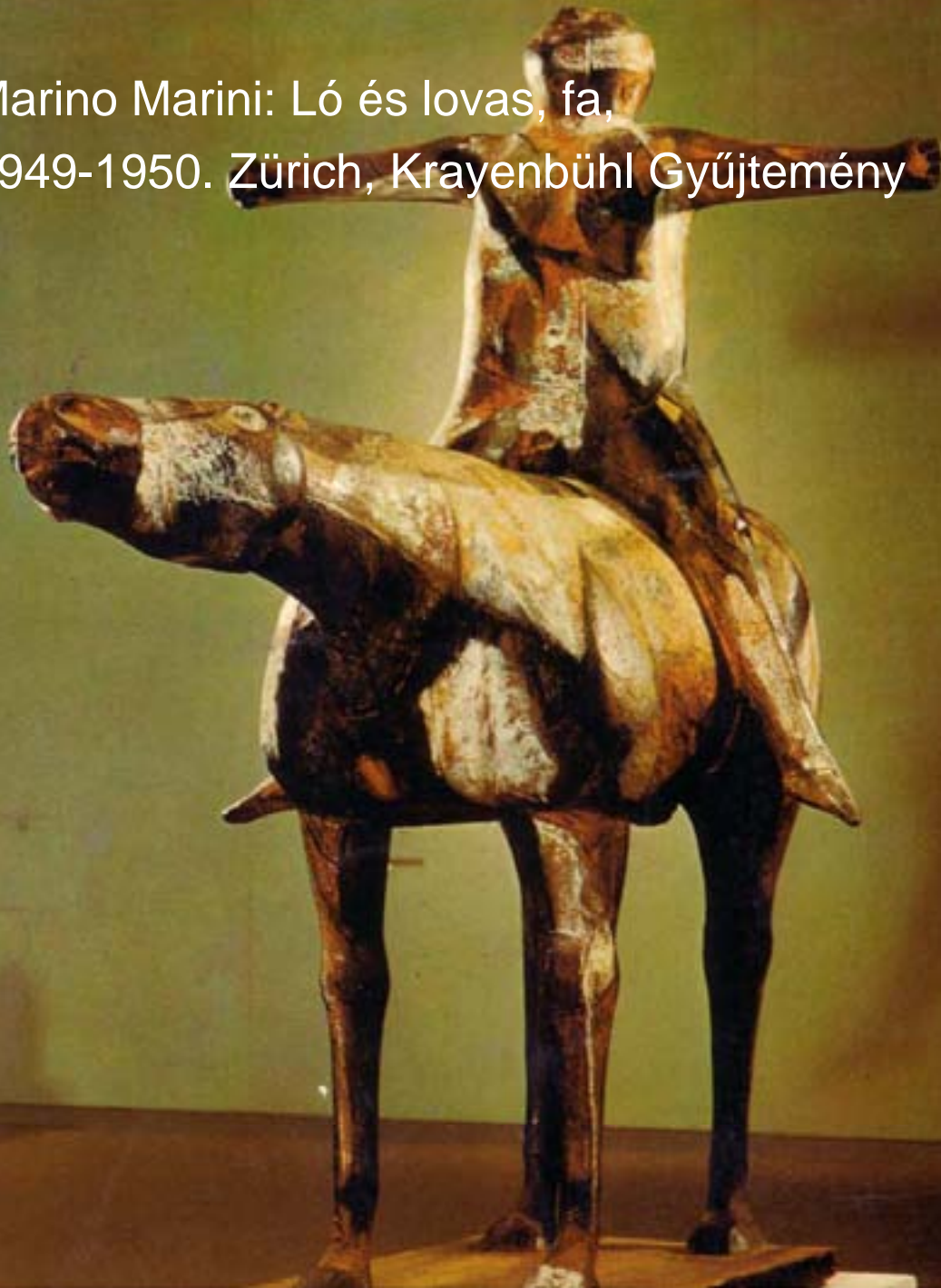



Alberto Giacometti: Az erdő (bronz), 1950. Duisburg,  
Wilhelm Lehmbruck Gyűjtemény





495 Henry Moore: Kétrészes fekvő alak (bronz), 1959. művész tulajdona

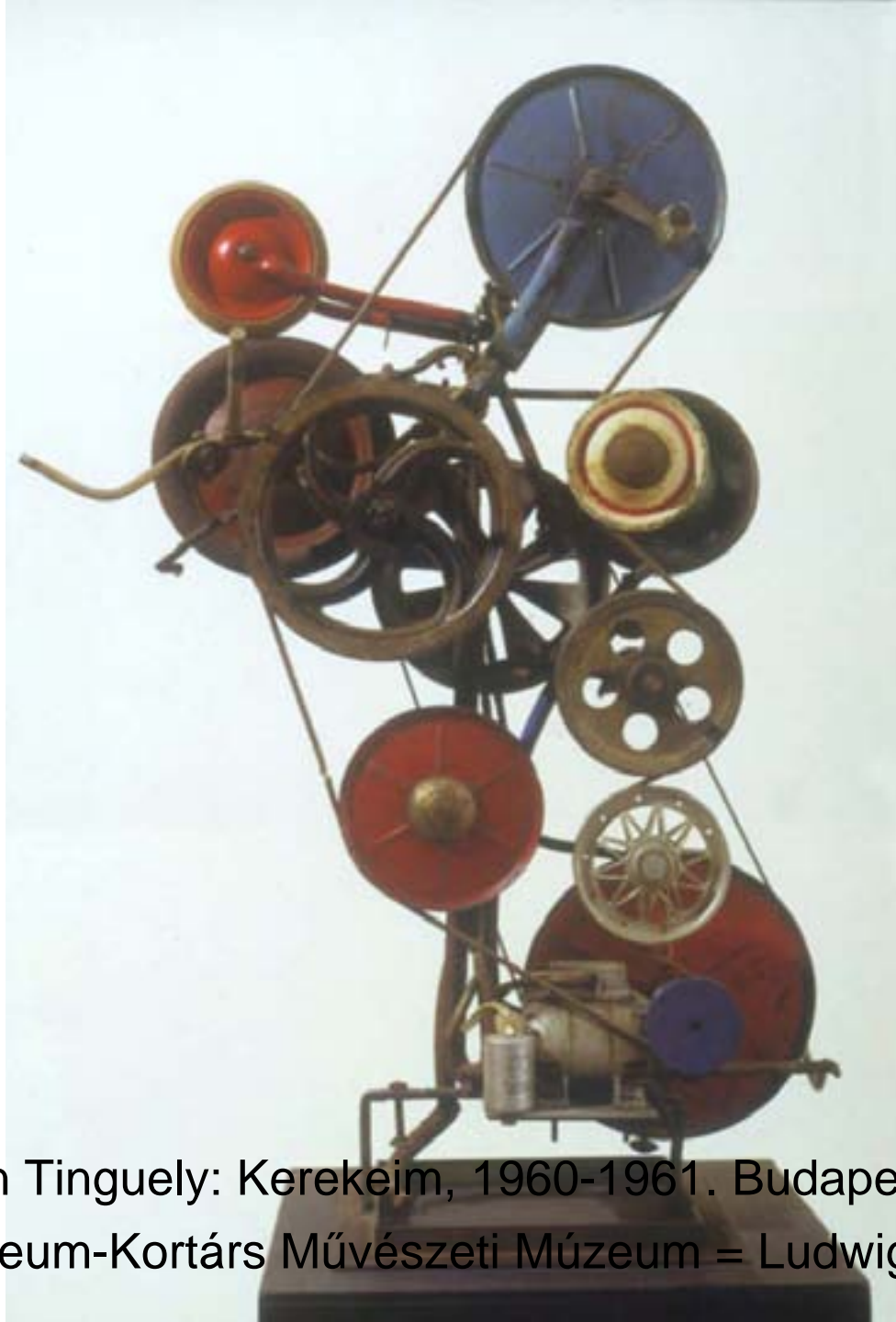

Jean Tinguely: Kerekeim, 1960-1961. Budapest, Ludwig  
Múzeum-Kortárs Művészeti Múzeum = Ludwig





497 Miro: A hold fala, kerámia, 1960. Párizs, UNESCO Palota kertje

Rothko: Fehér középpont  
(sárga,  
rózsaszín és  
levendula vörösön),  
1950







499

Somogyi József: Martinász, 1953. Dunaújváros

Borsos Miklós: Madár tojással, 1968.





Lucio Fontana

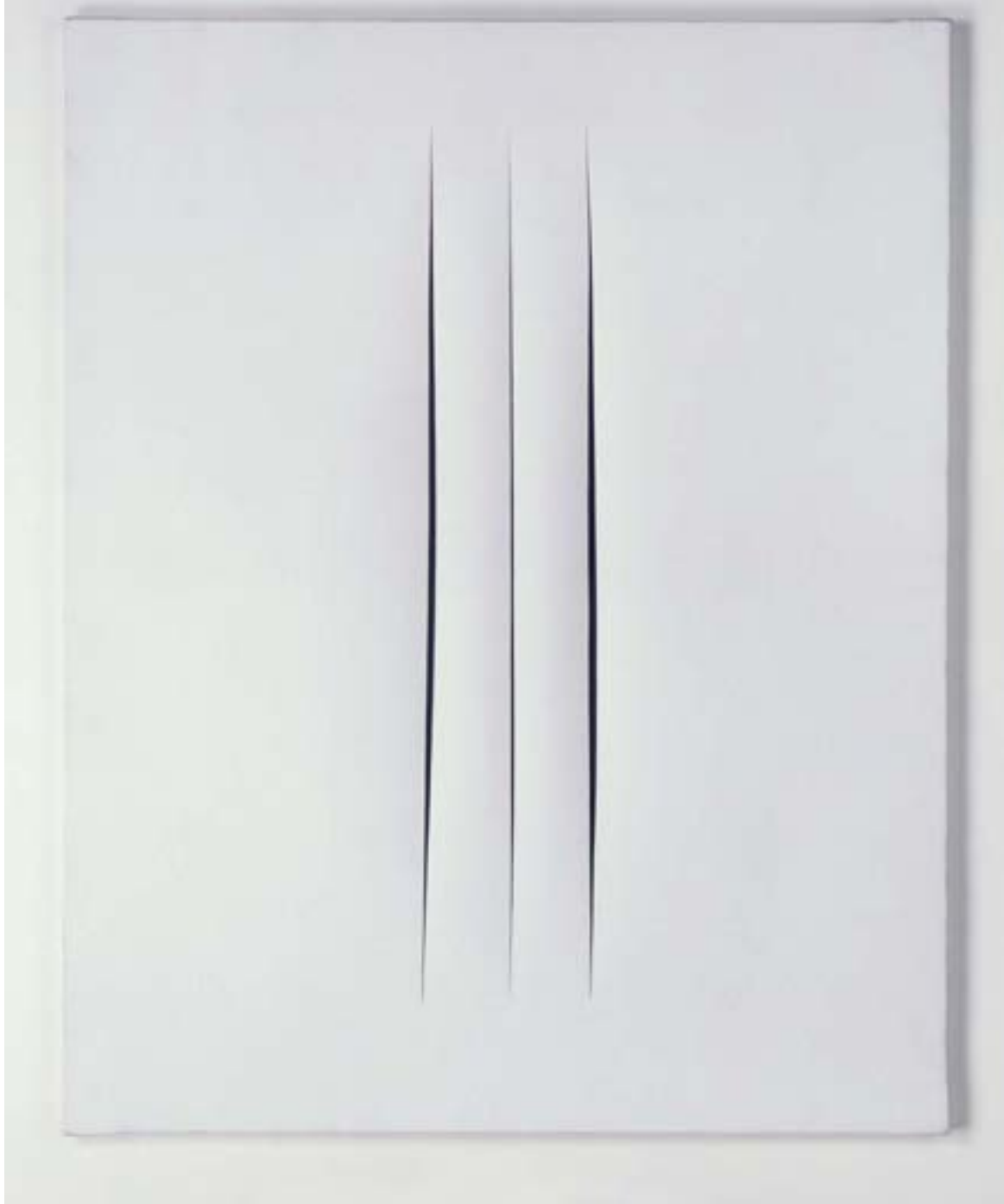

501



502



Jovánovics György:  
Részlet a nagy Gilles-ből,  
1967-1968. (mgt.)





504

Schaár Erzsébet: Az utca, 1974. székesfehérvári kiállítás



Varga Imre:  
Radnóti  
1969.  
Mohács



Jackson Pollock: No 14. 1948. Westport, Connecticut, mggy.

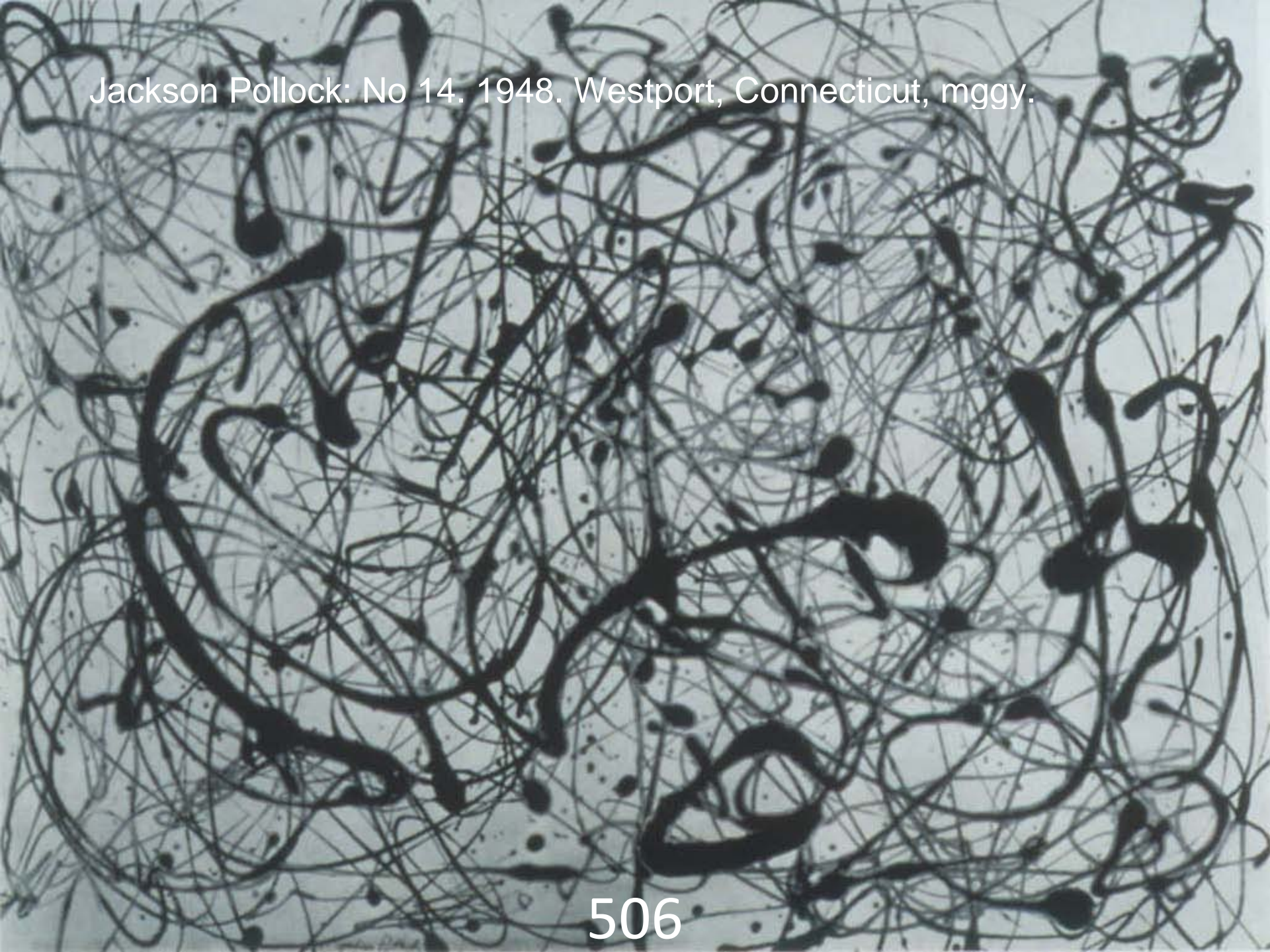



Jean Dubuffet: Metafizikus, 1950.  
(Winnetka-Illinois, mggy.)



Francis Bacon:

Tanulmány Velázquez után: X. Ince pápa.  
mgt.

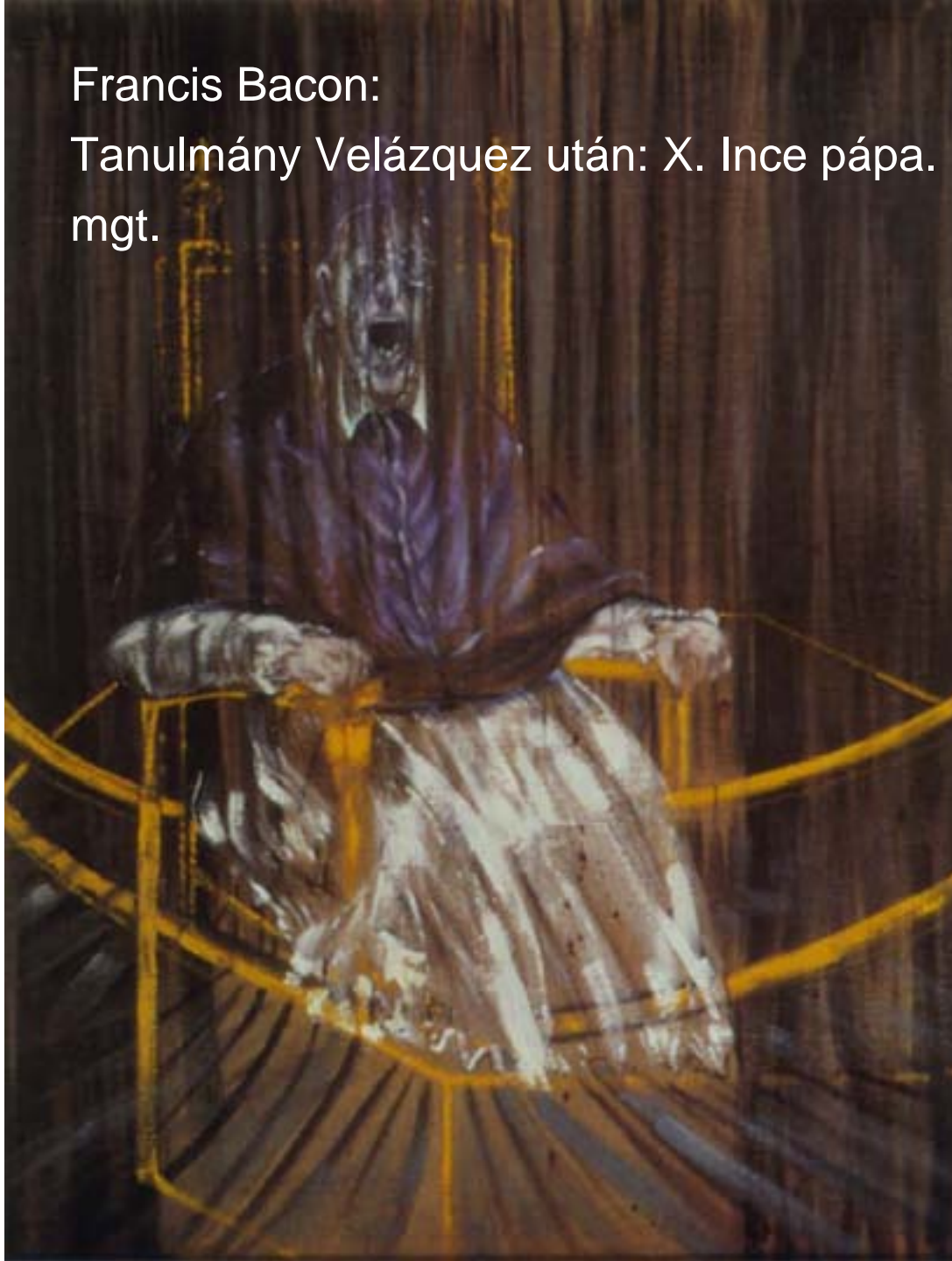





(Jasper) Johns: Zászló narancsmezőben, 1957. (Köln, Wallraf Richart Museum)

Liechtenstein:  
Tzing, 1962.  
Darmstadt,  
Karl Ströher  
gyűjtemény





Warhol:  
Elvis,  
1964.  
Toronto,  
Art Gallery  
of Ontario



Rauschenberg:  
Turkey,  
1965.  
Darmstadt,  
Karl Ströher  
gyűjtemény





Kepes György:  
Programozott  
fényjátékterv  
a bostoni  
kikötő számára,  
1965-1967

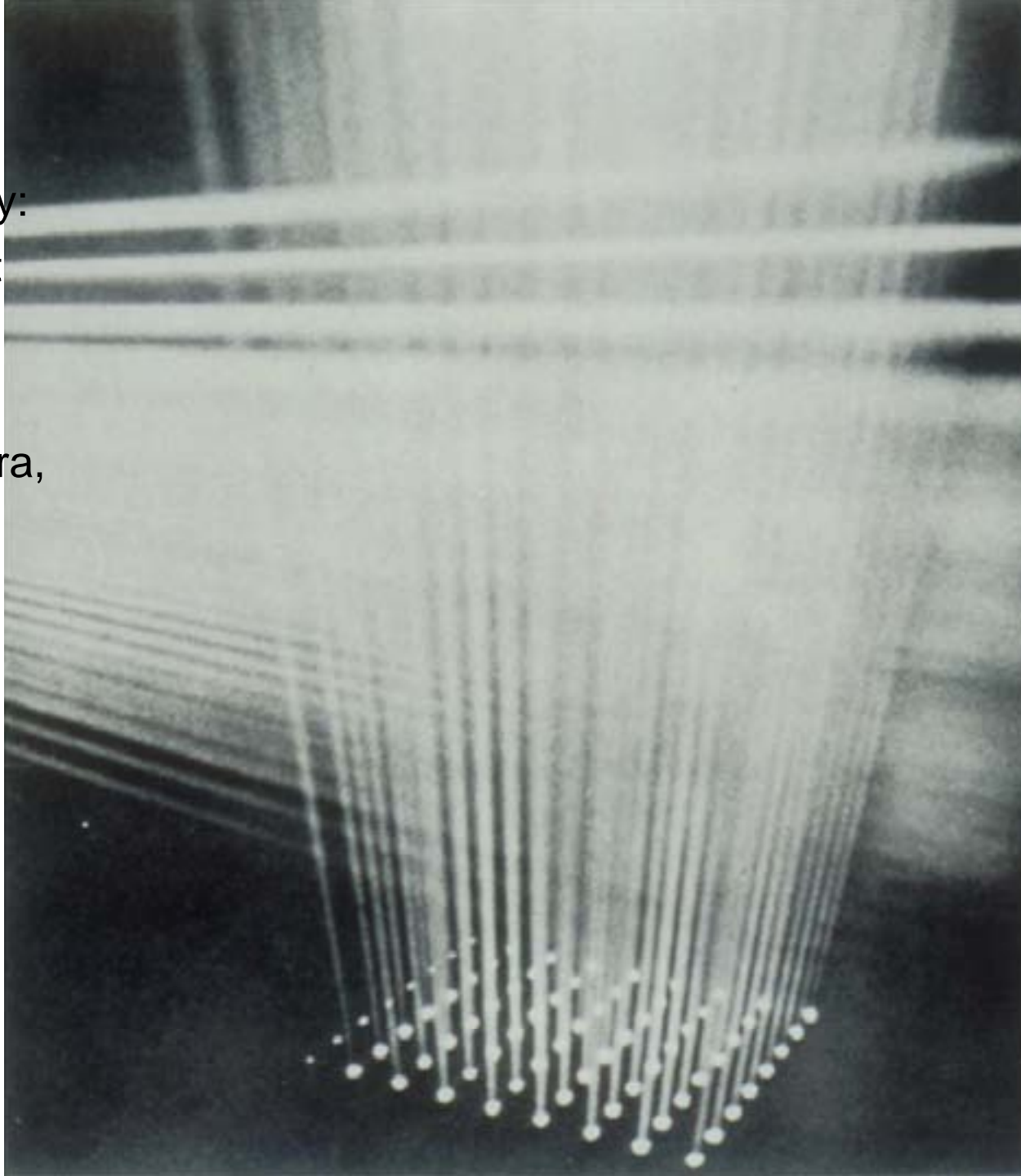

Vasarely  
egy  
op-art  
műve

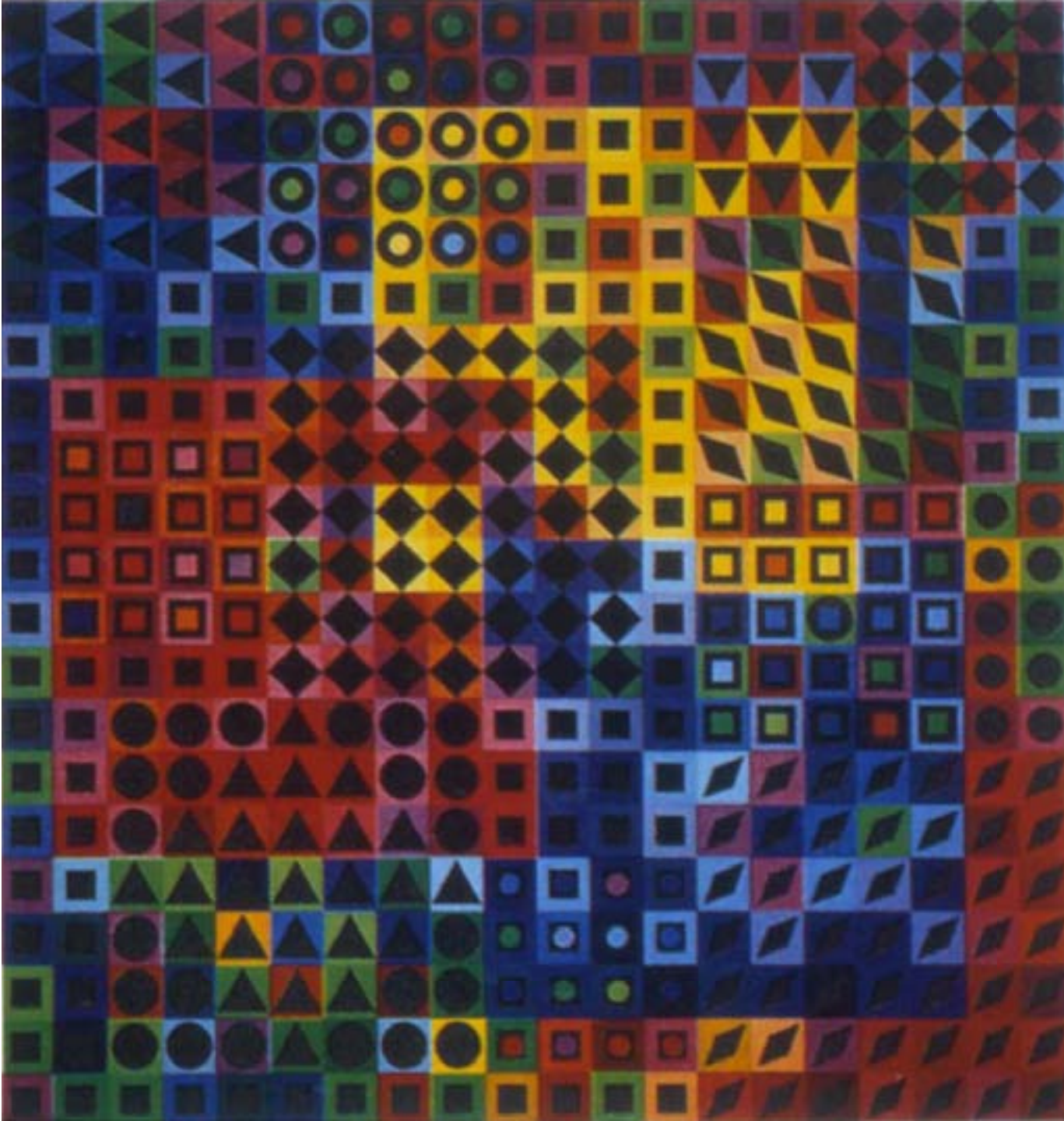



Yves Klein:  
IKB 191

Piero  
Manzoni:  
Artist's Shit  
1961.





Arman  
(Fernandez  
Armand):  
Long term  
parking  
1982.



César Baldaccini:  
Hüvelykujj  
1965.  
Párizs







Daniel Spoerri:

Eaten by Marcel Duchamp. 1964.

Frank Stella: Lake City, 1960-1961. Düsseldorf, Kunstmuseum

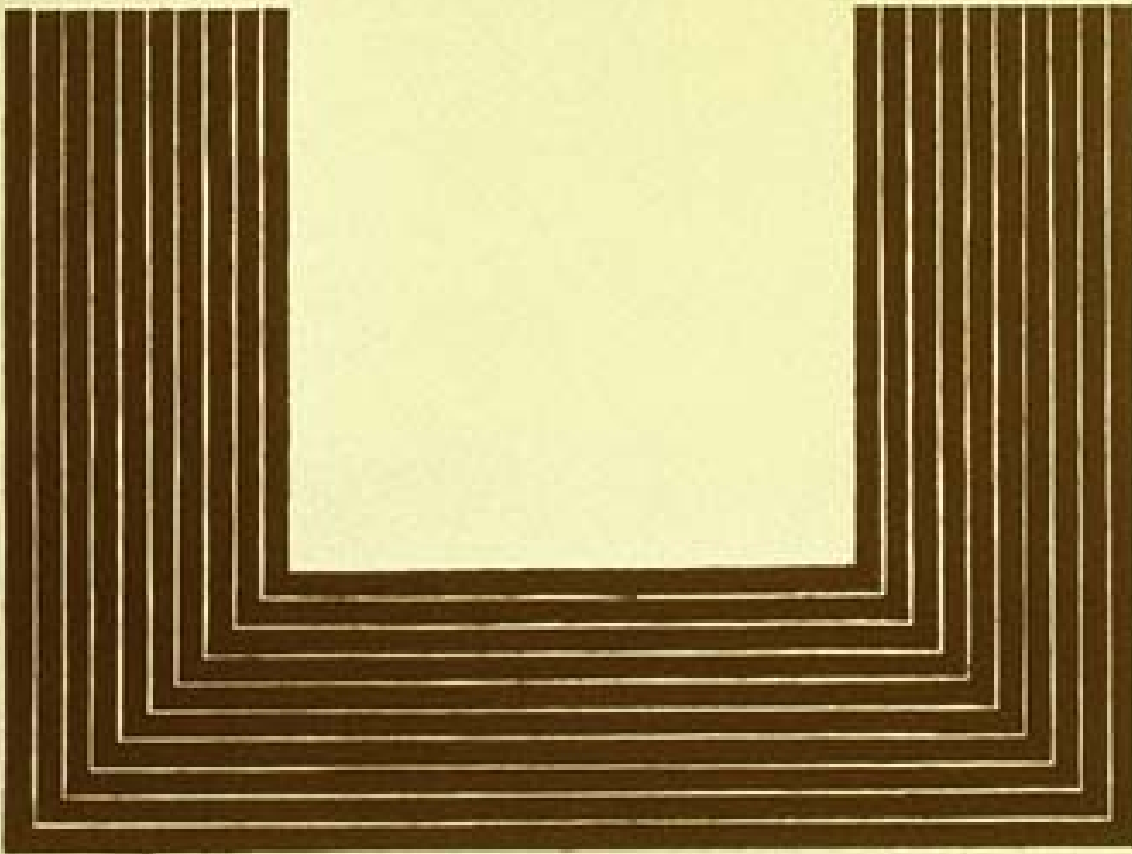





521 Allan Kaprow: Házirtás, 1964. Happening fotódokumentáció

# Joseph Kosuth: Egy és három szék, 1965.



chair, n hence v; chaise (longue) and chay;  
(ex) cathedra, cathedral (adj and n), cathedraic;  
element -hedral, -hedron, q.v. sep.

1. Gr *hedra*, a seat (cf Gr *hezesthai*, to sit, and, ult, E *SIT*), combines with *kata*, down (cf the prefix *cata-*), to form *kathedra*, a backed, four-legged, often two-armed seat, whence L *cathedra*, LL bishop's chair, ML professor's chair, hence dignity, as in 'to speak *ex cathedra*', as from—or as if from—a professor's chair, hence with authority. L *cathedra* has LL-ML adj *cathedrālis*—see sep CATHEDRAL; and the secondary ML adj *cathe-drāticus*, whence E legal *cathedraic*.









Joseph Beuys:  
How to explain  
pictures to a dead  
hare 1965.



J. Beuys:  
Fat Chair  
1964.





Joseph Beuys Joseph Beuys in the Action 'Mainstream' (1967, printed 1997)

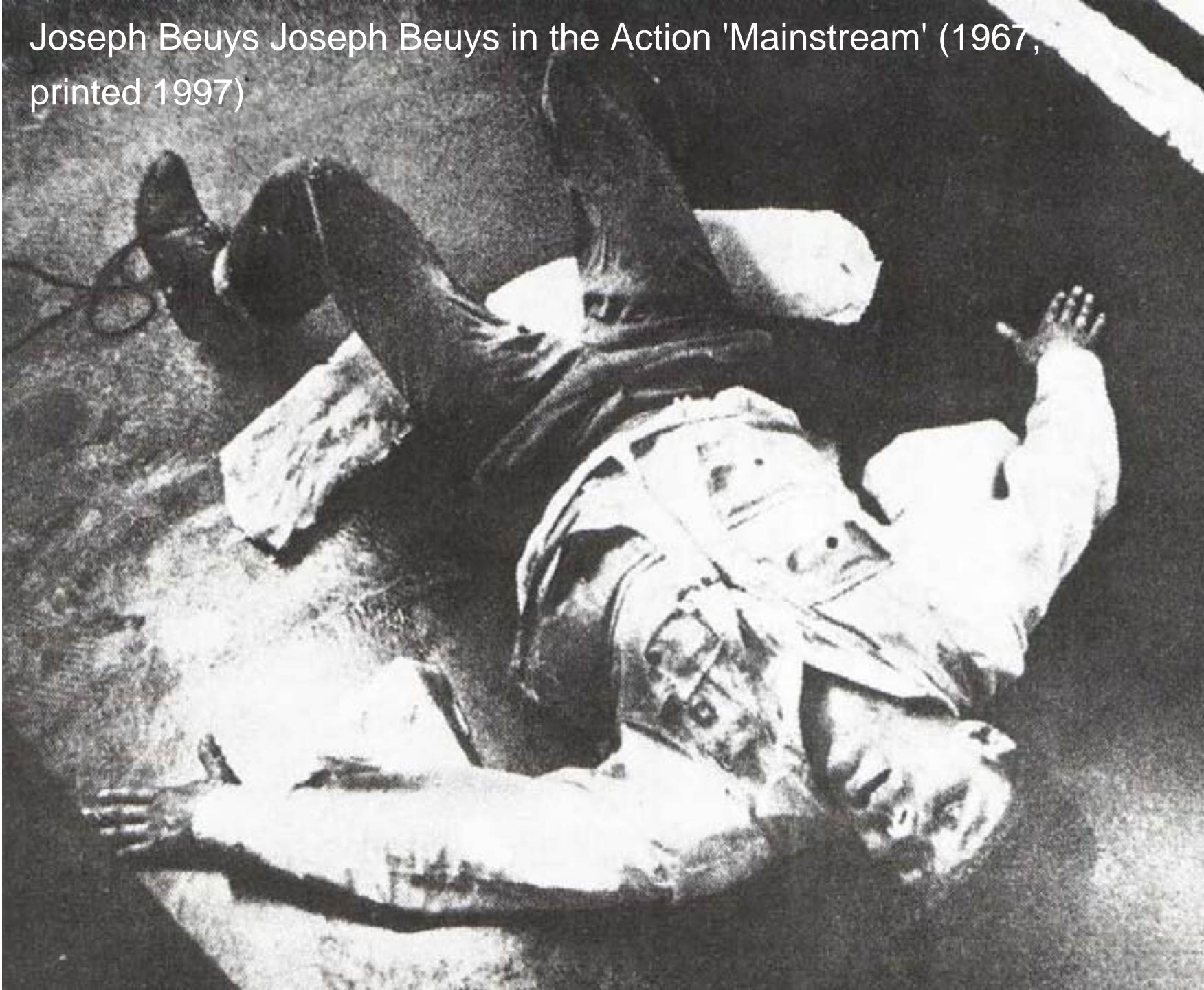

Nam June Paik:  
TV cselló premier  
1971.  
(TV Cello,  
Concerto for TV)

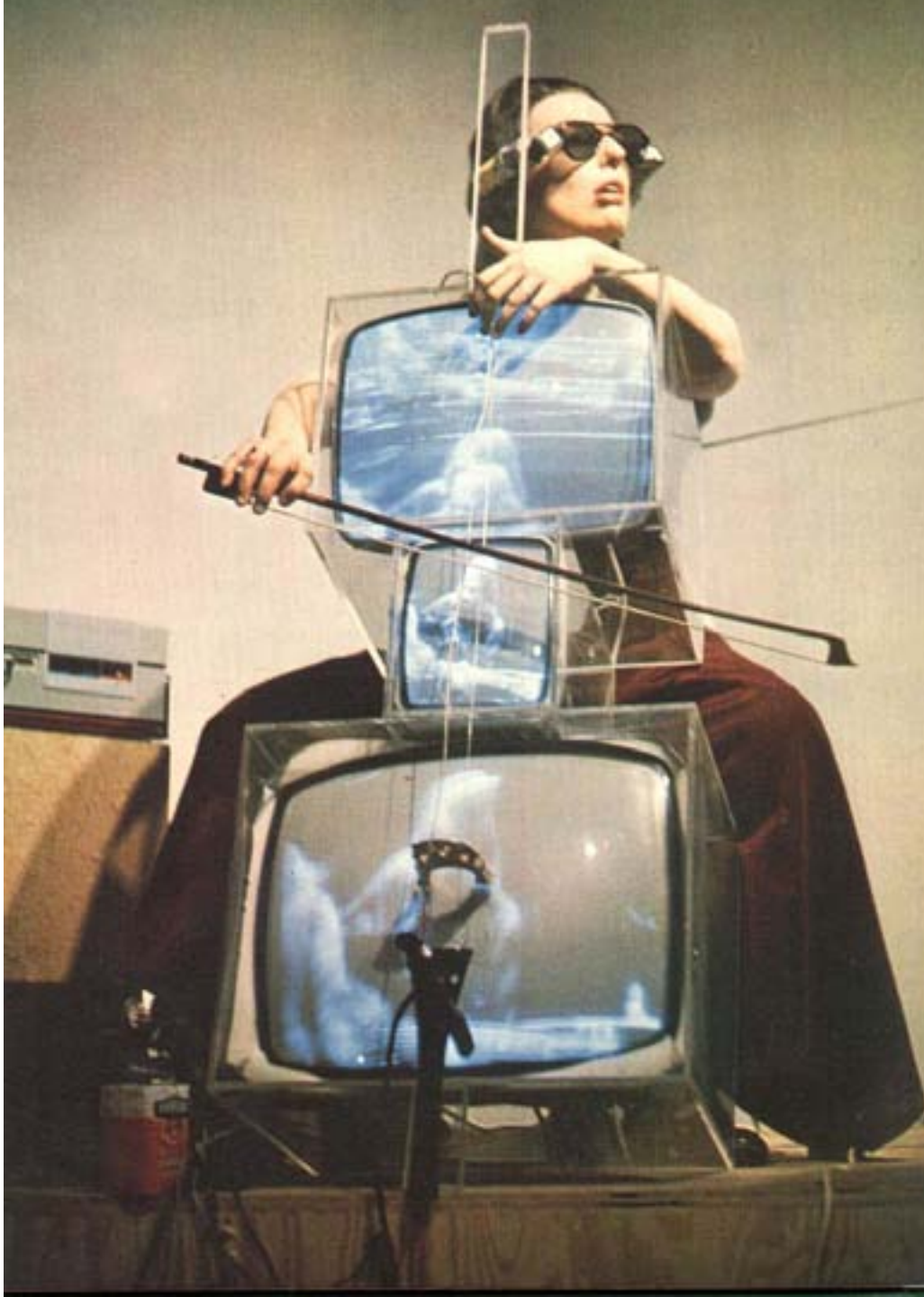





Christo: 1972-ben Colorado államban 381 méter széles narancssárga

529

függönyt feszített ki, melynek a Valley Curtain nevet adta.

Claes Oldenburg:  
Csipesz 1976.  
Philadelphia  
Centre Square  
Plaza







**531** Claes Oldenburgh: Kanálhíd és cseresznye 1985-88. Walker Art Cent.

Szentjóby Tamás: Hülő víz, 1965. (mggy.)



532



Kondor Béla: Rajz, 1969. (Győr, Kolozsváry gyűjtemény)



Lakner László: Mosoly, 1969. (Budapest, Kiscelli Múzeum)

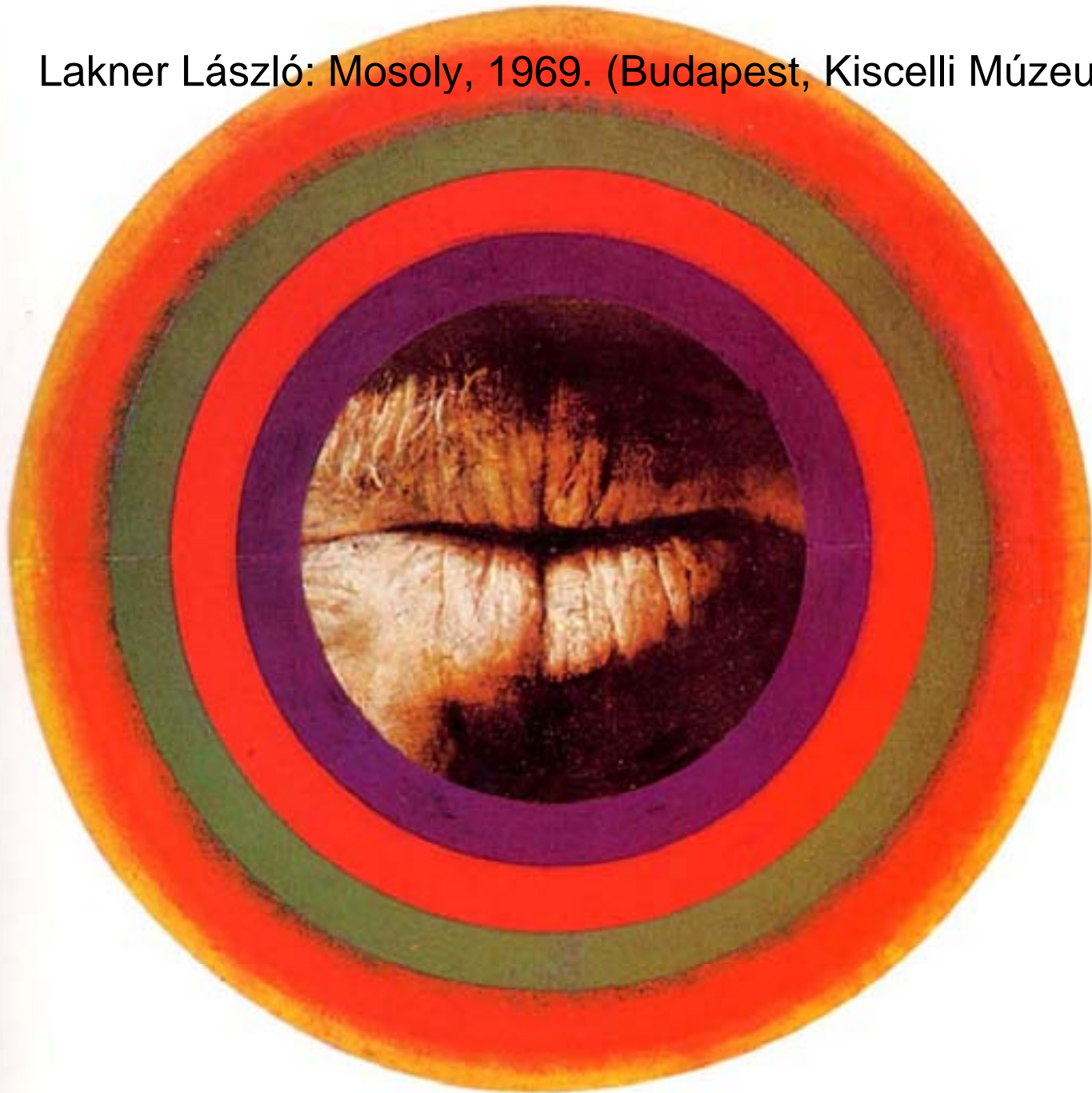



Pauer Gyula: Pszeudo, 1970. (mgt.)

535



Haraszty István: Kalitka, 1973. (Székesfehérvár, István Király Múzeum)



Erdély Miklós: Hűség, 1979.

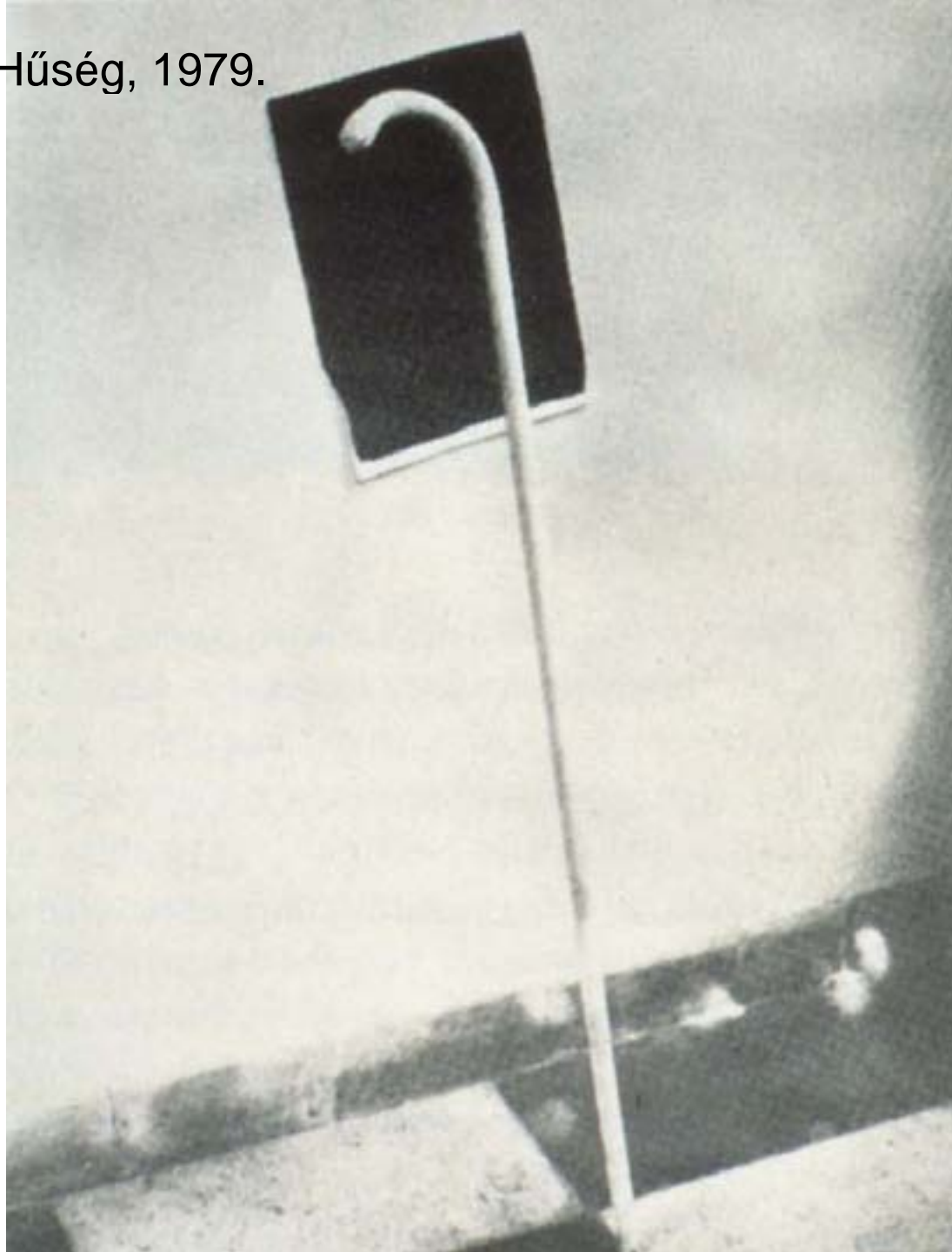

537

(Cindy) Sherman: Cím nélküli állókép 48., 1979.







539 Bak Imre: Tao, 1996. Ludwig

**Your body**

**is a**

**battleground**

Barbara Kruger:  
A tested csatatér,  
1989.





541 Rebecca Horn: Concert for Anarchy, 1994

Németh Ilona: Elementáris objekt, 1996.







543 Gerber Pál: Te egy kiválasztott vagy, 1996.

FOTÓ



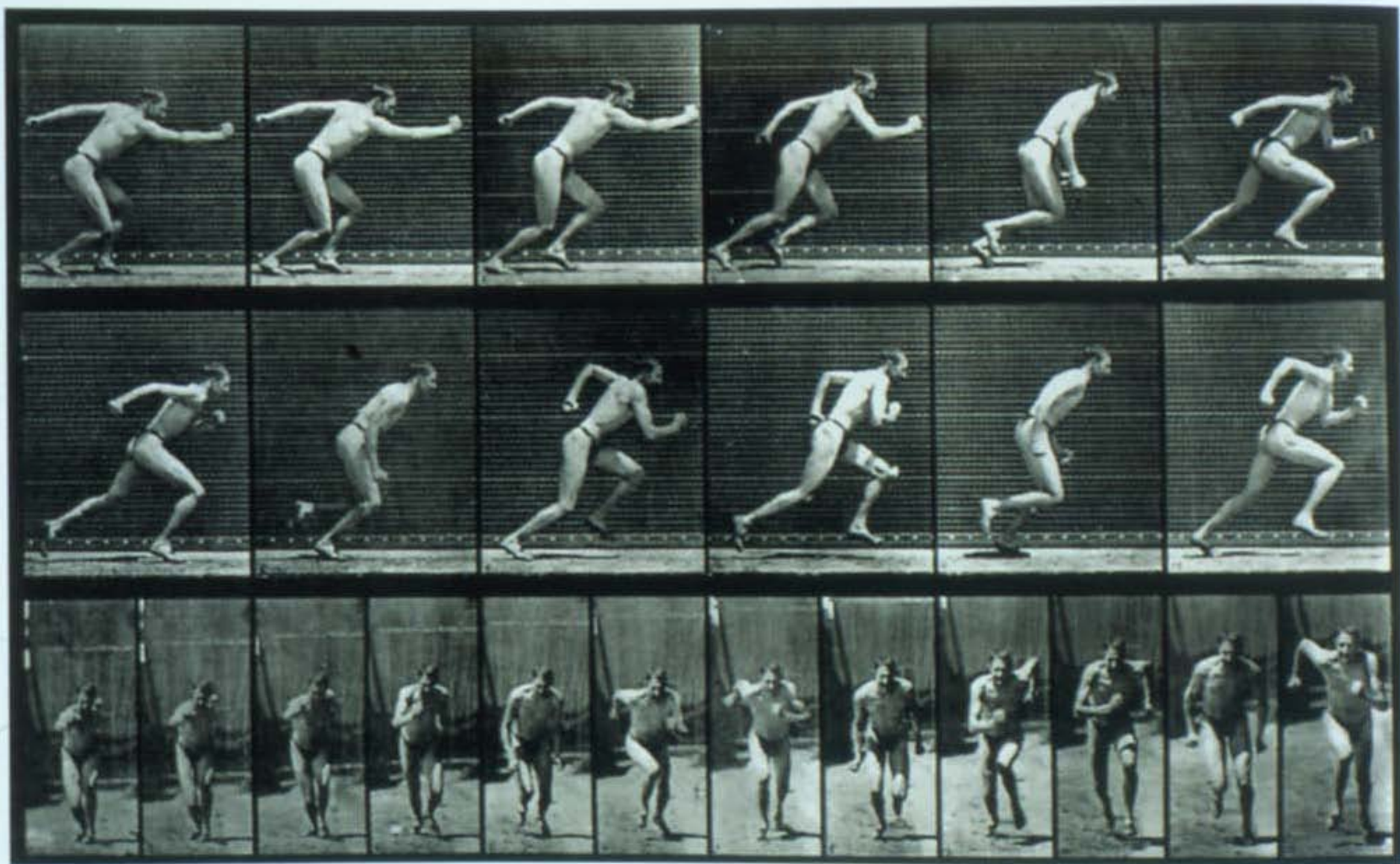

545 Eadweard Muybridge: A mozgás bűvöletében - kétlábon futó ember



Laci és Lucia 1925-28, fotogram  
(Moholy-Nagy Foundation)



Alexander  
Rodcsenko:  
Telefonáló nő



Man Ray:  
Casati grófnő  
1922.





Munkácsi:  
Gyerekek  
Bad Kissingenből  
Berliner  
Illustrierte  
Zeitung 1929.



Edward Weston: Cabbage Leaf, 1931.



550



Kertész: Torzulások 1933.

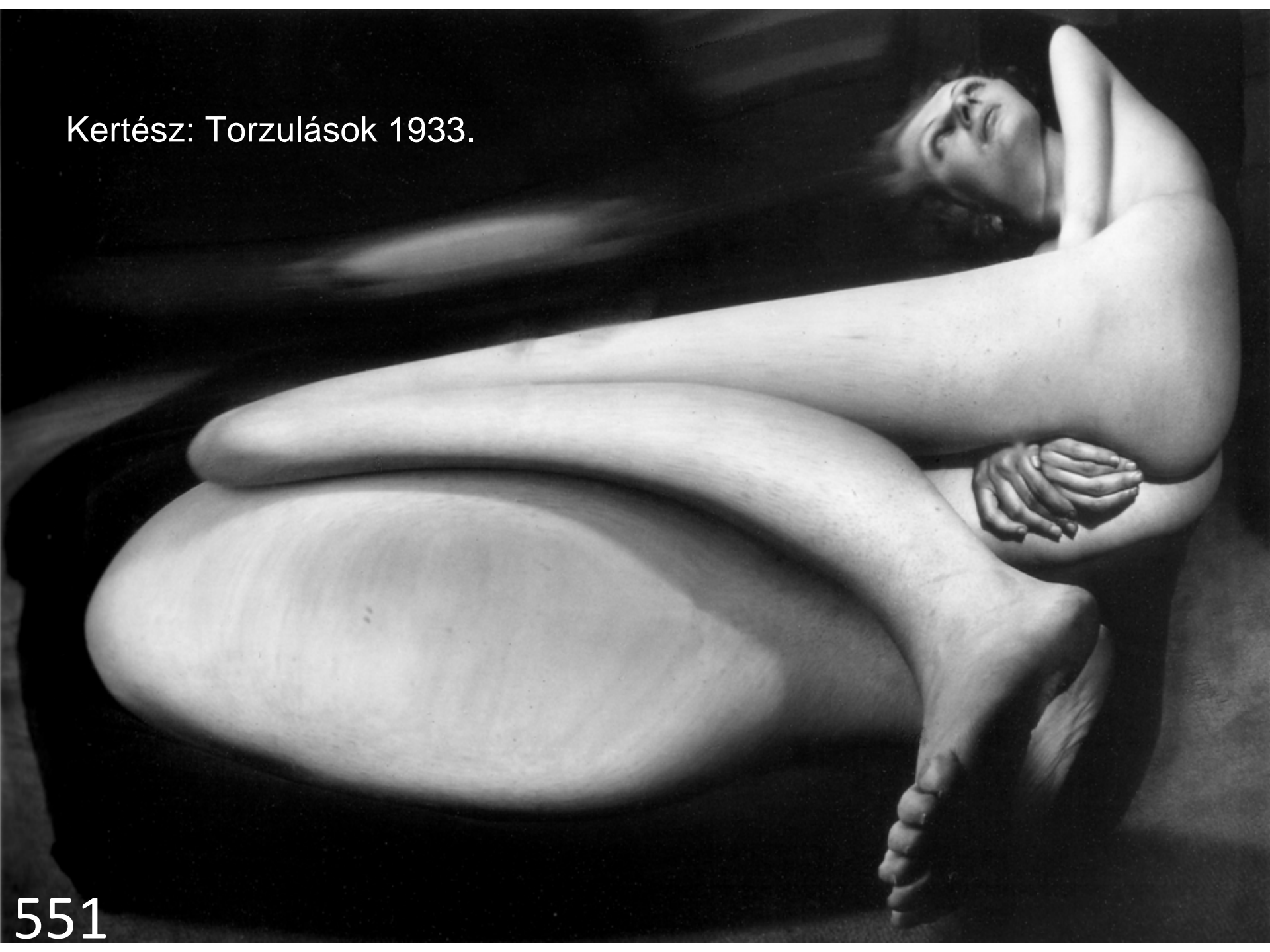



552 Sunday on the Banks of the River Marne © Henri Cartier-Bresson, 1938.





Capa: Kollaboráns nő, akinek német katonától született gyermeke. Chartres, 1944. augusztus 18.

Diane Arbus: Brooklyn family going for Sunday outing  
1966.

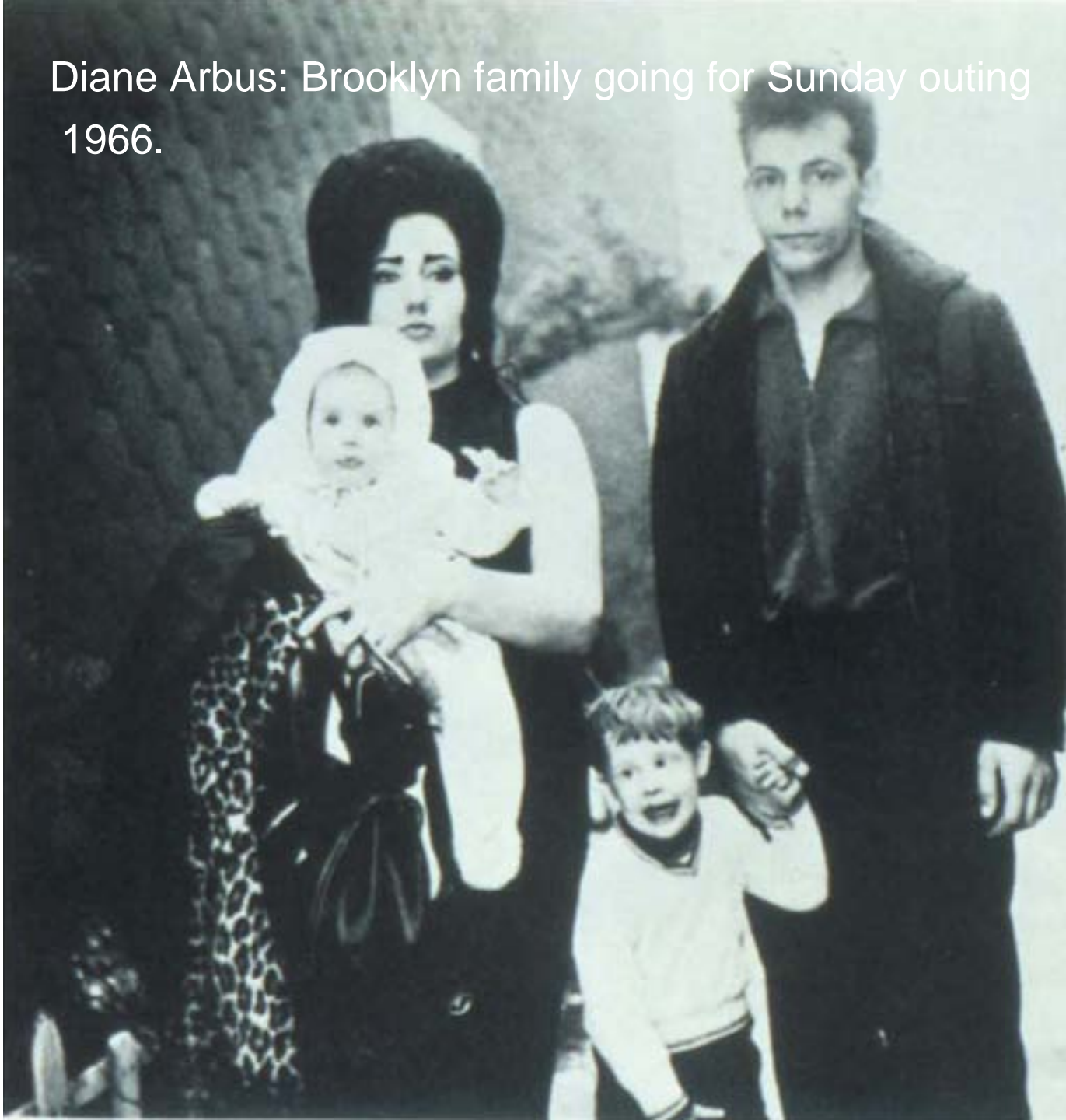



Avedon: Jacob Israel Avdeon 1974. Camera Magazine







NÉPRAJZ







559



560





561







563







565















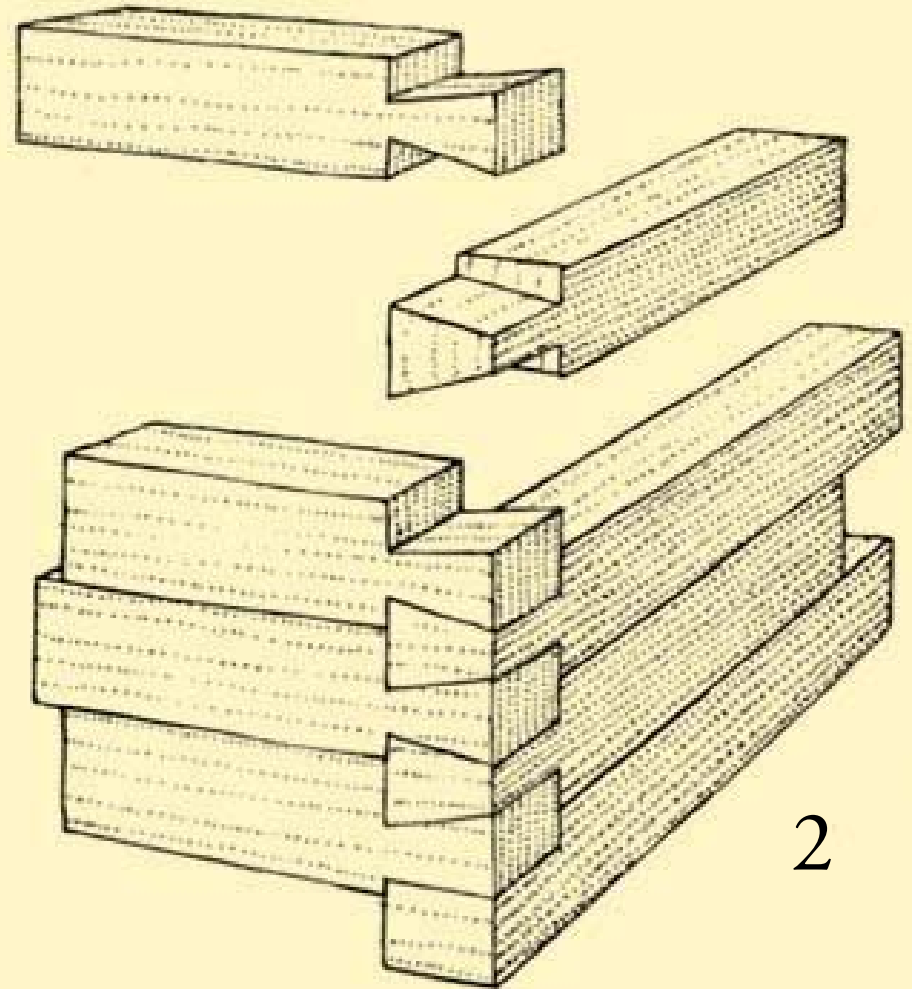
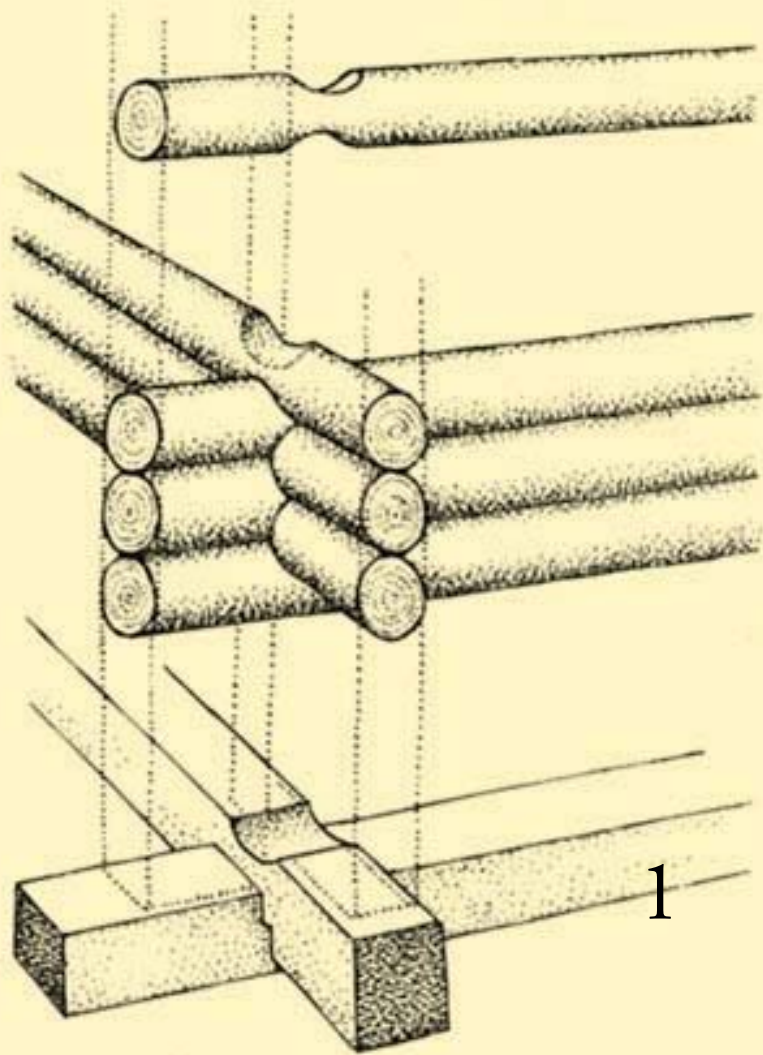





571













575



ISTEN HOZOTT HA MÉSZ ISTEN LEGYEN VELED





577

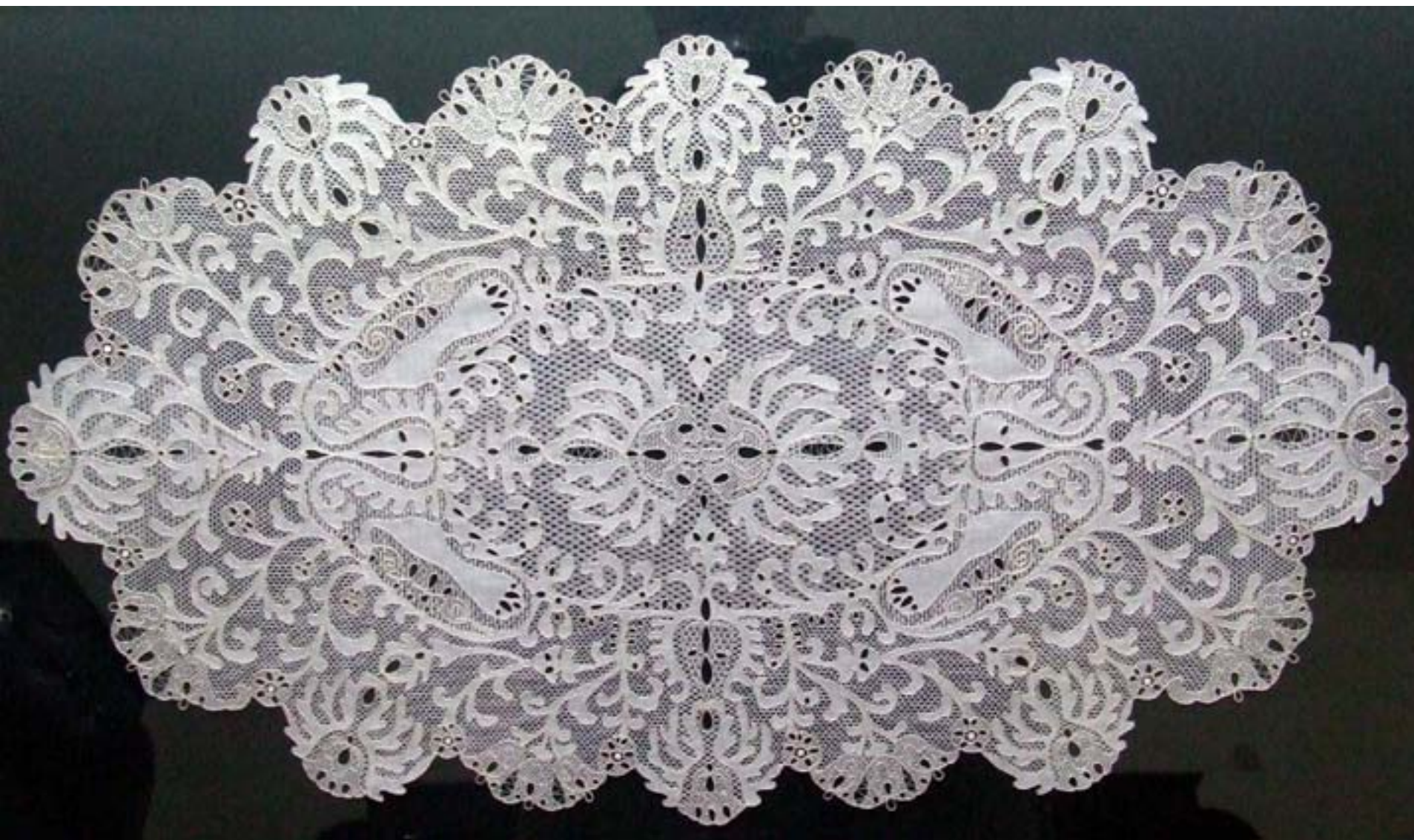

578





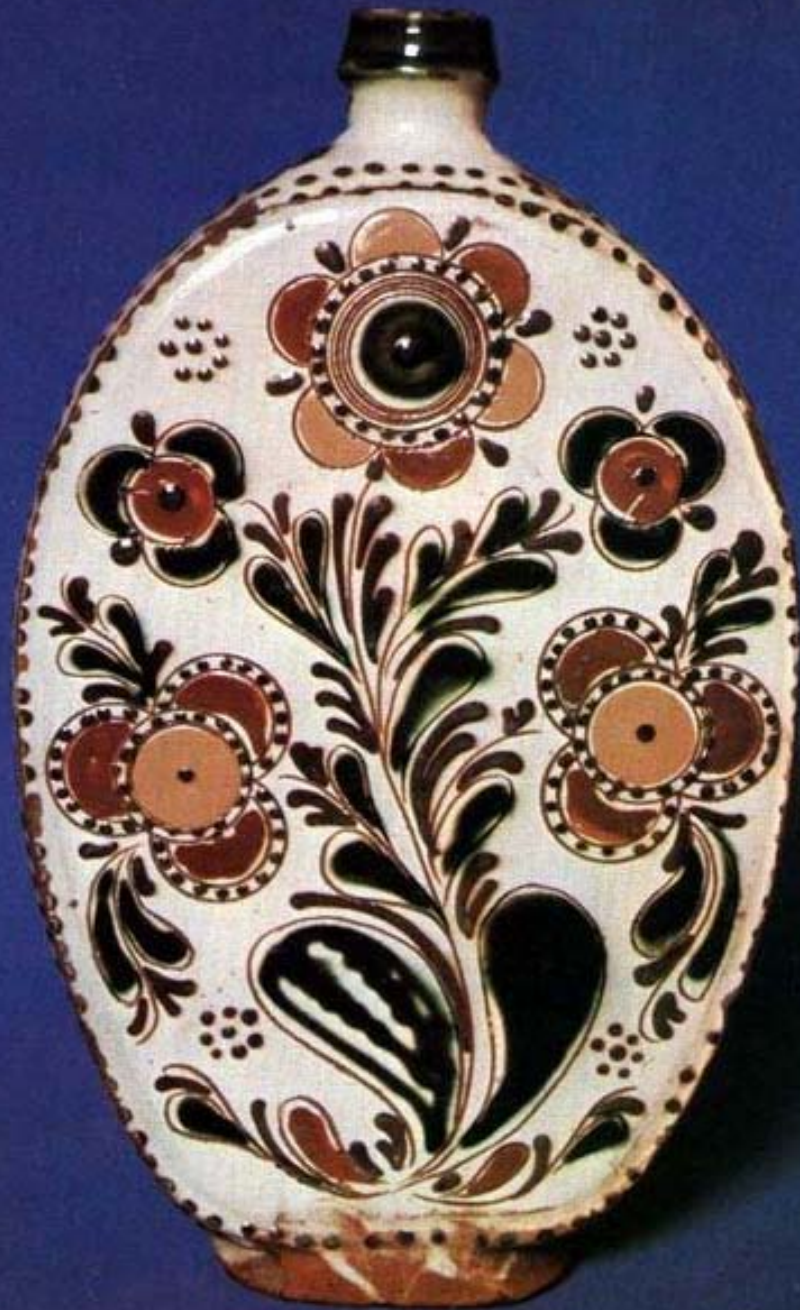

580





581







583



584





585



586